

# Service Manual

Facsimile

UF-580/590/780/790

UF-5100/6000/6100

[Version 2.0]



## WARNING

This service information is designed for experienced repair technicians only and is not intended for use by the general public. It does not contain warnings or cautions to advise non-technical individuals of potential dangers in attempting to service a product. Products powered by electricity should be serviced or repaired only by experienced professional technicians. Any attempt to service or repair the product or products dealt within this service information by anyone else could result in serious injury or death.

## IMPORTANT SAFETY NOTICE

There are special components used in this equipment which are important for safety. These parts are marked by  in the Schematic Diagrams, Circuit Board Diagrams, Exploded Views and Replacement Parts List. It is essential that these critical parts should be replaced with manufacturer's specified parts to prevent shock, fire or other hazards. Do not modify the original design without permission of manufacturer.

**Panasonic**<sup>®</sup>

© 2005 Panasonic Communications Co., Ltd.  
All rights reserved. Unauthorized copying and distribution is a violation of law.

## **This Product Uses Lead (Pb) Free Solder Printed Circuit Boards (PCBs).**

Information regarding Lead-Free (PbF) solder:

Distinction of PbF PCB:

PCBs (manufactured) using lead free solder will have a **PbF** mark following the PCB part numbers in a label on the PCB.

### **Caution:**

- Pb free solder has a higher melting point than standard solder; typically the melting point is 50 - 70 °F (30 - 40 °C) higher. Please use a soldering iron with temperature control and adjust it to 700±20 °F (370±10 °C). Exercise care while using higher temperature soldering irons, do not heat the PCB for too long to prevent solder splash or damage to the PCB.
- Pb free solder will tend to splash when heated too high (about 1100 °F/600 °C).
- ECO SOLDER M705 (available from Senju Metal Industry Co., Ltd.:  
URL: <http://www.senju-m.co.jp>) is recommended when repairing PbF PCBs.

The contents of this Service Manual and the Specifications are subject to change without notice.

Panasonic Communications Co., Ltd. reserves the right to make improvements in the product design without reservation and without notice.

Published in Japan.

# **Important Notice**

Please read this notice completely **BEFORE** repairing or installing any optional accessories. Repairing or installing the additional board or connector with the power ON could damage the SC board.

## **Please follow the instructions below:**

1. It is essential that you unplug the AC Power Cord from the wall outlet. (There is a remote possibility of electrocution when servicing the unit during a Lightning Storm. To protect yourself disconnect the Telephone Line Cable before unplugging the AC Power Cord.)
2. Please read the installation instructions carefully and follow each step. <Example: UF-6000>

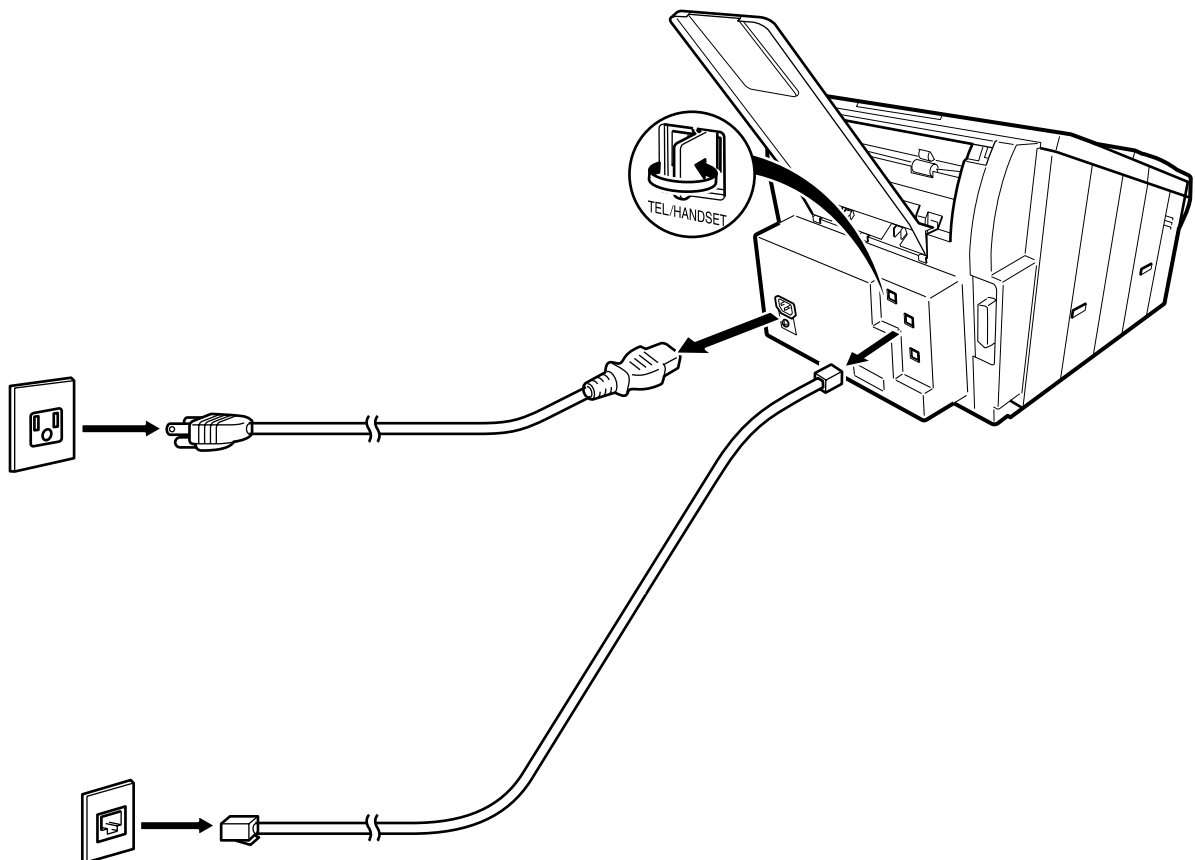

\* The specifications are subject to change without notice. Panasonic Communications Co., Ltd. reserves the right to make improvements in the product design without reservation and without notice.

# Wichtiger Hinweis

Diesen Hinweis bitte ganz durchlesen, BEVOR optionales Zubehör installiert wird. Ansonsten bei inkorrektem Einbau bzw. Anschluss der zusätzlichen Leiterplatte, wenn die Netzspannung zugeschaltet ist, die SC- Leiterplatte der Maschine beschädigt werden könnte.

## **Bitte die Anweisungen unten beachten:**

1. Unbedingt das Netzkabel aus der Wandsteckdose ziehen. (Falls die Fax-Option installiert ist, sollte bei einem Gewitter das Telefonkabel entfernt werden, bevor das Netzkabel gezogen wird, um einen elektrischen Schlag zu vermeiden.)
2. Die Installationsanleitung sorgfältig durchlesen und genau befolgen.

<Beispiel: UF-6000>

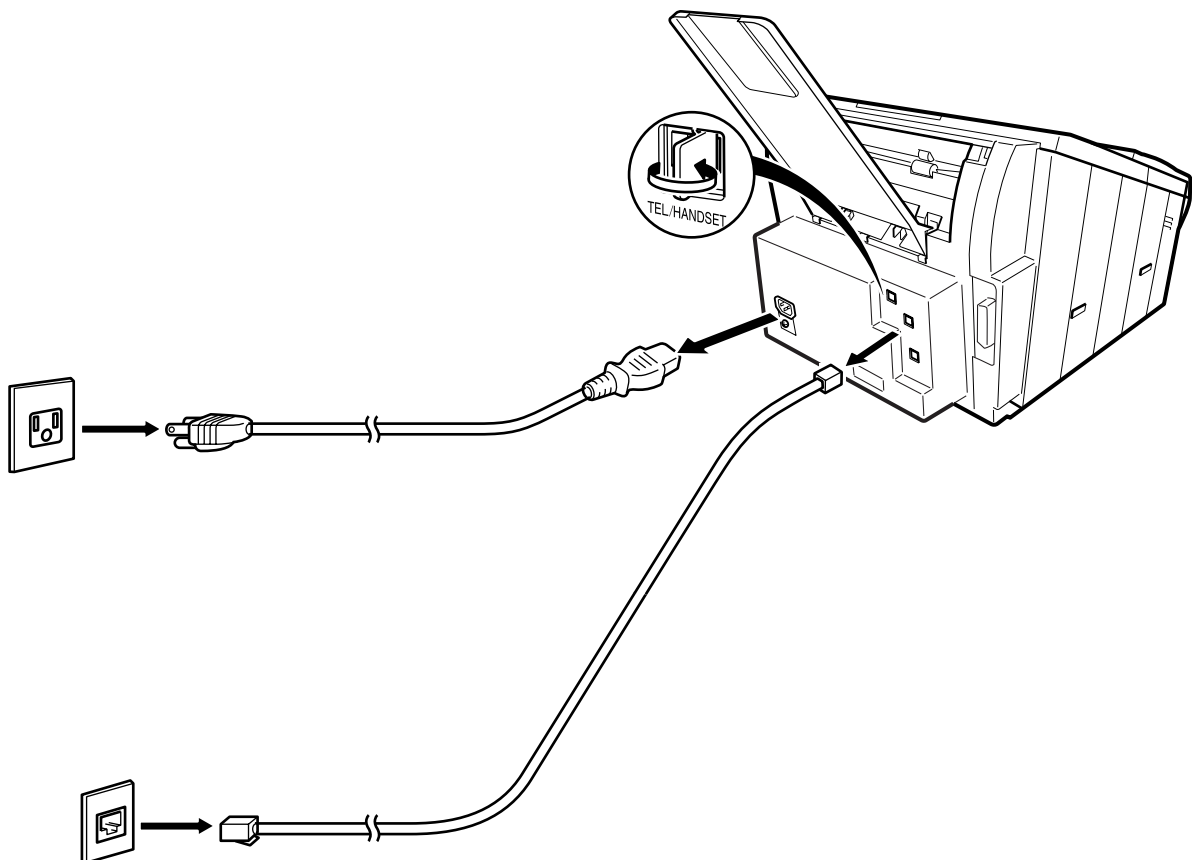

\* Technische Änderungen jederzeit vorbehalten. Panasonic Communications Co., Ltd. behält sich das Recht vor, jederzeit und ohne Mitteilung Verbesserungen des Produkt-Design durchzuführen.

## For Your Safety

To prevent severe injury and loss of life, read this section carefully before servicing the Panasonic machine to ensure proper and safe operation of your machine.

Please ensure that the machine is installed near a wall outlet and is easily accessible.

- This section explains the Warnings and Cautions used in the machine and/or this manual.



**WARNING:** Denotes a potential hazard that could result in serious injury or death.



**CAUTION:** Denotes hazards that could result in minor injury or damage to the machine.

- This section also explains the Warnings and Cautions used in the machine and/or this manual.



These symbols are used to alert operators to a specific operating procedure that must not be performed.



These symbols are used to alert operators to a specific operating procedure that must be emphasized in order to operate the machine safely.



### WARNING

## Power and Ground Connection Cautions



Ensure that the plug connection is free of dust. In a damp environment, a contaminated connector can draw a significant amount of current that can generate heat and eventually cause fire if left unattended over an extended period of time.



Always use the power cord provided with your machine. When an extension power cord is required, always use a properly rated cord.

- 120 V/15 A or AC 220 - 240V/10 A

If you use a cord with an unspecified current rating, the machine or plug may emit smoke or become hot to the touch.



Do not attempt to repair, pull, bend, chafe or otherwise damage the power cord. Do not place a heavy object on the cord. A damaged cord can cause fire or electric shocks.



Never touch a power cord with wet hands. Danger of electric shock exists.



If the power cord is damaged or insulated wires are exposed, contact your Service Provider for a replacement. Using a damaged cord can cause fire or electric shocks.



Stop operation immediately if your machine emits smoke, excessive heat, unusual noise, or abnormal smell, or if water is spilt onto the machine. These conditions can cause fire. Immediately switch Off and unplug the machine, and contact your Service Provider dealer.



When disconnecting the machine, grasp the plug instead of the cord. Pulling on a cord forcibly can damage it and cause fire or electric shock.



When the machine is not used over an extended period of time, switch it Off and unplug it. If an unused machine is left connected to a power source for a long period, degraded insulation can cause electric shocks, current leakage or fire.



Be sure to switch Off and unplug the machine before accessing the interior of the machine for cleaning, maintenance or fault clearance. Access to a live machine's interior can cause electric shock.



Once a month, unplug the machine and check the power cord for the following. If you notice any unusual condition, contact your Service Provider.

- The power cord is plugged firmly into the receptacle.
- The plug is not excessively heated, rusted, or bent.
- The plug and receptacle are free of dust.
- The cord is not cracked or frayed.

## Operating Safeguards



Do not touch areas where these caution labels are attached to, the surface may be very hot and may cause severe burns.



Do not place any liquid container such as a vase or coffee cup on the machine. Spilt water can cause fire or shock hazard.



Do not place any metal parts such as staples or clips on the machine. If metal and flammable parts get into the machine, they can short-circuit internal components, and cause fire or electric shocks.



If debris (metal or liquid) gets into the machine, switch Off and unplug the machine immediately. Operating a debris-contaminated machine can cause fire or electric shock.



Do not try to alter the machine configuration or modify any parts. An unauthorized modification can cause smoke or fire.

## Consumable Safeguards



Never dispose of toner, toner cartridge or a waste toner container into an open flame. Toner remaining in the cartridge can cause an explosion, burns and/or injuries.



Keep button batteries/stamp out of the reach of children. If a button battery/stamp is swallowed accidentally, get medical treatment immediately.



## CAUTION

## Installation and Relocation Cautions



Do not place the machine near heaters or volatile, flammable, or combustible materials such as curtains that may catch fire.



Do not place the machine in a hot, humid, dusty or poorly ventilated environment. Prolonged exposure to these adverse conditions can cause fire or electric shocks.



Place the machine on a level and sturdy surface that can with stand. If tilted, the machine may tip-over and cause injuries.



When relocating the machine, remove the toner and/or developer, and pack the machine with proper packing materials for shipping.



When moving the machine, be sure to unplug the power cord from the outlet. If the machine is moved with the power cord attached, it can cause damage to the cord which could result in fire or electric shock.



## CAUTION



Do not place a magnet near the safety switch of the machine. A magnet can activate the machine accidentally resulting in injuries.



Do not use a highly flammable spray or solvent near the machine. It can cause fire.



When copying a thick document, do not use excessive force to press it against the document glass. The glass may break and cause injuries.



Never touch a labeled area found on or near the heat roller. You can get burnt. If a sheet of paper is wrapped around the heat roller, do not try to remove it when it is hot, to avoid injuries or burns. Switch Off the machine immediately, and wait until it cools down.



Do not use conductive paper, e.g. folding paper, carbonic paper and coated paper. When a paper jam occurs, they can cause a short circuit and fire.



Do not place any heavy object on the machine. An off-balance machine can tip-over or the heavy object can fall, causing damage and/or injuries.



Keep the room ventilated when using the machine for an extended period of time to minimize the ozone density in the air.



When copying with the document cover open, do not look directly at the exposure lamp. Direct eye exposure can cause eye fatigue or damage.



Pull out paper trays slowly to prevent injuries.



When removing jammed paper, make sure that no pieces of torn paper are left in the machine. A piece of paper remaining in the machine can cause fire. If a sheet of paper is wrapped around the heat roller, or when clearing a jammed paper that is difficult or impossible to see, do not try to remove it by yourself. Doing so can cause injuries or burns. Switch Off the machine immediately, and wait until it cools down.

## Consumable Safeguards



## WARNING



Never throw a toner cartridge into an open flame. Toner remaining in the cartridge can cause an explosion and you can get burnt.



Never throw toner or a waste toner container or a toner cartridge into an open flame. It can cause an explosion and you can get burnt.



Keep button batteries out of the reach of children. If a button battery is swallowed accidentally, get medical treatment immediately.



## CAUTION



Never heat the drum cartridge, or scratch its surface. A heated or scratched drum can be hazardous to your health.



Do not mix new and old batteries together. Otherwise, batteries can burst or leak, causing fire or injuries.



Be sure to use the specified type of batteries only.



Ensure that batteries are installed with correct polarity. Incorrectly installed batteries can burst or leak, resulting in spillage or injuries.

memo



# Table of Contents

<b>Specifications Table</b> .....	11	<b>System Description</b> .....	193
1.1. Fax Function .....	11	6.1. Mechanical Operation .....	193
1.2. Printer Function .....	19	6.2. Electrical Circuit Explanation.....	202
1.3. External View.....	21	<b>Exploded View &amp; Parts List</b> .....	228
1.4. Control Panel.....	23	7.1. Destination Codes.....	228
<b>Disassembly Instructions</b> .....	25	7.2. Cover Assembly .....	229
2.1. General Disassembly Flowchart.....	25	7.3. Control Panel Unit.....	233
2.2. Disassembly Instructions .....	26	7.4. Transmitter Assembly .....	239
2.3. Hardware Identification Template .....	53	7.5. Electrical Parts .....	243
<b>Maintenance, Adjustments and</b>		7.6. Base Unit.....	246
<b>Check Points</b> .....	54	7.7. Paper Transportation .....	251
3.1. Required Tools .....	54	7.8. Fuser Unit.....	255
3.2. Periodic Check Points.....	54	7.9. Cassette .....	260
3.3. Periodic Maintenance Check List .....	55	7.10. Optional Cassette	
3.4. Updating the Firmware .....	56	(Except UF-580/780/5100).....	262
3.5. Glossary of Electrical Abbreviations .....	62	7.11. PC Board / Harness .....	265
3.6. SC PC Board .....	65	7.12. Packing and Accessories .....	271
3.7. MJR PC Board.....	85	<b>Installation</b> .....	275
3.8. Power Supply Unit .....	86	8.1. Function Key .....	275
3.9. PNL PC Board .....	88	8.2. Main Unit and Accessories.....	276
3.10. SNS3 PC Board.....	90	8.3. Installing the Accessories.....	277
3.11. SNS4 PC Board.....	91	8.4. Installing the Toner Cartridge.....	278
3.12. SNS1 PC Board.....	92	8.5. Loading the Recording Paper .....	281
3.13. SNS2 PC Board.....	92	8.6. Adjusting the Paper Cassette for	
3.14. CCD PC Board .....	92	the Paper Length.....	283
3.15. ILS PC Board.....	92	8.7. Adjusting the Paper Cassette for	
3.16. ACI PC Board .....	92	the Paper Width .....	284
3.17. CST2 PC Board (Optional) .....	93	8.8. Connecting the Telephone Line	
3.18. SNS2 PC Board (Optional) .....	93	Cable and Power Cord.....	285
3.19. SRU PC Board (Optional).....	94	8.9. Customizing Your Machine .....	286
<b>Troubleshooting</b> .....	95	<b>Options and Supplies</b> .....	291
4.1. Initial Troubleshooting Flowchart.....	95	9.1. Options and Supplies .....	291
4.2. Improper LCD Display .....	96	9.2. Installing Optional 250 Sheet Paper	
4.3. Information Codes (INFO. CODES).....	97	Cassette (UE-409070) .....	292
4.4. Printed Copy Quality Problems.....	109	9.3. Installing Handset Kit (UE-403176).....	294
4.5. Document Feeder (ADF) .....	125	<b>Schematic Diagram</b> .....	295
4.6. Communications .....	128	10.1. General Circuit Diagram.....	295
4.7. Information Codes Table		10.2. SC PC Board	
(For Facsimile).....	134	(For UF-580/590/780/790) .....	297
4.8. Diagnostic Codes (For Facsimile).....	139	10.3. SC PC Board	
<b>Service Modes</b> .....	146	(For UF-5100/6000/6100) .....	311
5.1. Service Modes (For Facsimile).....	146	10.4. PNL1 PC Board.....	325
		10.5. MJR PC Board .....	327
		10.6. SNS1 PC Board .....	328

# Table of Contents

- 10.7. SNS2 PC Board..... 329
- 10.8. SNS3 PC Board..... 330
- 10.9. SNS4 PC Board..... 331
- 10.10. CCD PC Board  
    (For UF-580/590/780/790) ..... 332
- 10.11. CCD PC Board  
    (For UF-5100/6000/6100) ..... 333
- 10.12. ILS PC Board..... 334
- 10.13. ACI PC Board ..... 335
- 10.14. Power Supply Unit (HVPS) ..... 336
- 10.15. Power Supply Unit (LVPS)..... 340

# 1 Specifications Table

## 1.1. Fax Function

Items	Description				Remarks
	UF-5100	UF-580/ 780	UF-6000/ 6100	UF-590/ 790	
<b>Main Specifications</b>					
1 Compatibility	G3				ITU-T Std. & Non-Std. (PCC)
2 PSTN Line Port	Yes				
3 Leased Line Port	No				
4 V.24 Line Port	No				
5 Modem Speed	33.6 - 2.4 kbps				With Automatic Fallback
6 Coding Scheme	MMR/MR/MH				
7 ECM	Yes				Conforms to ITU-T
8 Short Protocol	Yes (B, D)				
9 Transmission Speed	Approx. 3 sec				ITU-T Image No. 1 (A4, Std. Resolution)
10 Communication Resolution (dot / mm x lines / mm)	<b>Transmission</b> Std 8 x 3.85 Fine 8 x 7.7 S-Fine 8 x 15.4 16 x 15.4*  <b>Reception</b> Std 8 x 3.85 Fine 8 x 7.7 S-Fine 8 x 15.4 16 x 15.4				* Interpolated 16 dot/mm
<b>Scanner Mechanism</b>					
1 Scanning Device	CCD				
2 Scanning Speed					
	Std.	2.8 sec		Letter sized document	
		3.0 sec		A4 sized document	
	Fine	5.0 sec		Letter sized document	
		5.3 sec		A4 sized document	
	S-Fine	10.1 sec		Letter sized document	
		10.6 sec		A4 sized document	
3 Scanning Resolution (dot / mm x lines / mm)	Std. 8 x 3.85 Fine 8 x 7.7 S-Fine 8 x 15.4 16 x 15.4*				* Interpolated 16 dot/mm
4 Document Size (Max.)	10.1 x 78.7 in (257 x 2000 mm)				
5 Document Size (Min.)	5.8 x 5.0 in (148 x 128 mm)				
6 Effective Scanning Width	8.3 in (212 mm)				Letter size for USA and Canada
	8.2 in (208 mm)				A4 size for Other Destinations
7 Reduction XMT	No				

Items	Description				Remarks
	UF-5100	UF-580/ 780	UF-6000/ 6100	UF-590/ 790	
8 ADF Capacity	50 sheets*				*For USA and Canada only, documents must be inserted by staggered feed (stairs-shape). <b>Face Down</b> A4 / Letter 0.0024", 12 lb (0.06 mm, 45 g/m <sup>2</sup> ) to 0.0039", 16 lb (0.10 mm, 60 g/m <sup>2</sup> ) <b>Operating Environment</b> 68°F (20°C), 50%RH
	30 sheets*				*For Other Destinations. <b>Face Down</b> A4 / Letter 0.0024", 12 lb (0.06 mm, 45 g/m <sup>2</sup> ) to 0.0039", 16 lb (0.10 mm, 60 g/m <sup>2</sup> )
	20 sheets				<b>Face Down</b> A4 / Letter 0.0024", 12 lb (0.06 mm, 45 g/m <sup>2</sup> ) to 0.0048", 20 lb (0.12 mm, 75 g/m <sup>2</sup> )
9 Collation Stack	Yes (Face Down)				
<b>Printer Mechanism</b>					
1 Recording Method	LP				
2 Recording Speed	6.5 ppm				Letter sized paper
	6.2 ppm				A4 sized paper
3 Recording Resolution					
Copy, Fax	406 x 391 dpi				
	PC Printing Data	-	600 x 600 dpi 300 x 300 dpi		
4 Recording Paper Size	Letter / A4 / Legal				
5 Effective Printing Width	8.2 in (208 mm)				Letter size for USA and Canada
	8.0 in (202 mm)				A4 size for Other Destinations
6 Recording Paper Capacity	250 sheets				A4 / Letter / Legal (20 lb / 75 g/m <sup>2</sup> )
7 Collation Stack	Yes				Memory Collation Tray capacity: Up to 100 sheets
8 Consumables					See Consumables Section
<b>Memory / Clock</b>					
1 Standard Memory	8 MB (480 pages)	2 MB (120 pages)	8 MB (480 pages)	2 MB (120 pages)	ITU-T Image No. 1 (A4, Std. Resolution)
2 Memory Backup	Yes				
3 Document Memory type	Flash ROM				
4 Clock Backup	30 minutes				Use of a Gold Capacitor

Items	Description				Remarks
	UF-5100	UF-580/ 780	UF-6000/ 6100	UF-590/ 790	
<b>Copy Quality</b>					
1 Halftone (Tx)	Yes*				64-Level Error Diffusion * Halftone (S-Fine) only with the Resolution key
2 Super Fine (Tx & Rx) dpi x lpi (dot / mm x lines / mm)	406 x 391* (16 x 15.4)				* Interpolated 16 dot/mm
3 Original Contrast Selection (Tx)	Yes				3-Levels
4 Smoothing (Rx)					With Auto Picture / Text Recognition
Fax, Copy	Yes				
PC Printing Data	-	No			
<b>Power Supply</b>					
1 Power Requirement	108 - 132 VAC, 47 - 63 Hz, Single Phase				100 VAC Power Supply
	198 - 255 VAC, 47 - 63 Hz, Single Phase				200 VAC Power Supply
2 Power Consumption					
Standby Sleep Mode ES=On ES=Off Transmission Reception Copy Maximum	1.2 Wh				100 VAC Power Supply ES: Energy Saver
	6 Wh				
	21 Wh				
	17 W				
	460 W				
	470 W				
	470 W				
Standby Sleep Mode ES=On ES=Off Transmission Reception Copy Maximum	2.4 Wh				200 VAC Power Supply ES: Energy Saver
	6.5 Wh				
	22 Wh				
	17 W				
	480 W				
	480 W				
	490 W				
<b>Environment</b>					
1 Temperature					
Operation	50 to 95°F ( 10 to 35°C)				
Storage	-4 to 104°F (-20 to 40°C)				
Transport (Max. 72 hours)	-4 to 122°F (-20 to 50°C)				
2 Relative Humidity					
Operation	15 to 70% RH				
Storage	5 to 85% RH				
Transport (Max. 480 hours)	15 to 85% RH				

Items	Description				Remarks
	UF-5100	UF-580/ 780	UF-6000/ 6100	UF-590/ 790	
<b>Standards</b>					
1 PSTN	FCC Part 68 Industry Canada No. CS-03				
2 Safety	UL1950 (UL60950 3rd edition) CSA C22.2 No.950				
3 EMI	Class B computing device in FCC Part 15				
<b>Construction</b>					
1 Dimensions (W x D x H)	14.6 x 18.0 x 9.8 in (370 x 457 x 250 mm)				Excluding projections LTR
	14.6 x 18.7 x 9.8 in (370 x 474 x 250 mm)				Excluding projections A4
2 Weight (Excluding paper)	20 lb (9.0 kg)				Excluding consumable supplies and options
<b>Attachment &amp; Accessories</b>					
Toner Cartridge	Yes (1)		Yes (1)		
Operating Instructions	Yes (1)		Yes (1)		
CD-ROM	No		Yes (1) (PDMS)		
Power Cord	Yes (1)		Yes (1)		
Tel Line Cable	Yes (1)		Yes (1)		
Doc. Tray (Rx)	Yes (1)		Yes (1)		
<b>Consumables</b>					
1 Process Type	Toner Cartridge				
2 Yield (3% Black, ITU-T Image No. 1 Chart)	Approx. 7,500 pages				Multi Copy Mode Operation Environment 68°F (20°C), 50% RH, using A4 paper.
3 Low Toner Warning	Yes				Magnetic Sensor
<b>Options</b>					
1 Cassette & Deck 250 sheets	No		Yes		A4 / Letter / Legal (20 lb / 75 g/m <sup>2</sup> )
2 Document Memory	No	2 / 4 / 8MB	No	2 / 4 / 8MB	Flash Memory
3 Page Memory	No				D-RAM
4 Battery Backup 72 hours	No				
5 G3 Optional Communication Port	No				
6 Handset	Yes				Specified Destinations only
7 V.24/Encryption Interface	No				
8 PDL	No				

Items		Description				Remarks
		UF-5100	UF-580/ 780	UF-6000/ 6100	UF-590/ 790	
9	Parallel Port Interface	No		Standard		*HydraFax / LaserFAX Not Supported
	Printer Interface (GDI)	No		Standard		
	Scanner Interface (TWAIN)	No		Standard		
	Class 2 Fax Modem Interface	No		No	Standard	
	PC Fax Interface (PCC)	No		Standard		
	PC Fax Interface (LaserFAX)	No		No*		
	Document Manager	No		Standard		
	MFP Utilities	No		Standard		
<b>Languages</b>						
	Control Panel Function Label LCD Display Printouts Operating Instructions			English English English English English		English, C-French, Spanish can be selected for USA, Canada. Determined by Destinations.
<b>Multi-Task Operation</b>						
1	Multi Task Operation			Yes		
2	Direct XMT Reserve			Yes		
3	Memory XMT Reserve			Yes		
4	Number of Memory Job Files			10 files		
<b>Dialing/Telephone Features</b>						
1	One-Touch Keys			28		
2	One-Touch / Program Keys			4		
3	One-Touch Auto Dialers			32		
4	Abbr. Auto Dialers			100		
5	Total Auto Dialers			132		
6	Max. Tel Number Digits			36		
7	Max. Station Name Characters			15		
8	Directory Search Dialing			Yes		With Directory Search key
9	Full Number Dialing (Buffered Dialing)			Yes		Max. 12 stations
10	Direct Dialing (Monitor Dialing)			Yes		Voice mode (Monitor Dialing Mode) Requires to press START to start fax communication. Automatic Redialing is not available.
11	Automatic Redialing			Yes		
12	Manual Redialing			Yes		
13	Chain Dialing (Hybrid Dial)			Yes		On Monitor Dialing mode only
14	Line Monitor Speaker			Yes		
15	Pulse / Tone Dialing			Yes		10 pps / DTMF
16	Pulse to Tone Change			Yes		

Items	Description				Remarks
	UF-5100	UF-580/ 780	UF-6000/ 6100	UF-590/ 790	
17 Flash Key		Yes			
18 External Telephone Jack		1			Handset or External Telephone
<b>Transmission Features</b>					
1 Direct Transmission		Yes			ADF Transmission
2 Memory Transmission		Yes			Page Retransmission
3 Quick Memory Transmission		Yes			Dialing after 1st page stored
4 Multi-Station Transmission (Sequential Broadcasting)		Yes (Max.144)			
5 Direct Deferred Transmission		Yes			ADF Deferred Transmission
6 Deferred Memory Transmission		Yes			Max. 10 timers
7 Deferred Multi-Station Transmission		Yes (Max.144)			Max. 10 timers
8 Priority Direct Transmission		Yes			Priority ADF Transmission
9 Priority Memory Transmission		No			
10 Batch Transmission		No			
<b>Reception Features</b>					
1 Substitute Reception		Yes			
2 Fixed Reduction		Yes			LTR / A4: 70 - 100%, LGL: 80 -100% (in 1% Steps), Top & Center Alignment
3 Auto Reduction		Yes			LTR / A4: 70 - 100%, LGL: 80 -100% (in 1% Steps), Top & Center Alignment
4 Overlap Printing		Yes			Page End Approx. 0.39 in (10 mm)
5 Receive to Memory		Yes			
6 Distinctive Ring Detector (DRD)		Yes			Specified Destinations only
<b>Receive Control</b>					
1 Fax / Tel Auto Switch		Yes			Specified Destinations only
2 Silent Reception		No			
3 External TAM Interface		Yes			Specified Destinations only
4 Remote Reception		Yes (DTMF)			Specified Destinations only
<b>Polling</b>					
1 Polling		Yes			
2 Turnaround Polling		No			
3 Multi-Station Polling		Yes (Max.144)			
4 Deferred Polling		Yes			Max. 10 timers
5 Deferred Multi-Station Polling		Yes (Max.144)			Max. 10 timers



Items	Description				Remarks
	UF-5100	UF-580/ 780	UF-6000/ 6100	UF-590/ 790	
6 Direct Polling Tx			No		
7 Memory Polling Tx			Yes		1 File
8 Preset Polling Password			Yes		
9 Temporary Polling Password			Yes		
10 Continuous Polling			Yes		
<b>Convenience</b>					
1 Panel Display			Yes		20 x 2 Alphanumeric LCD
2 Voice Contact			No		
3 Edit File Mode			Yes		With View Mode
4 Incomplete File Save			Yes		With View Mode
5 Automatic Cover Sheet			Yes		
<b>Copy Features</b>					
1 Single Copy			Yes		
2 Multiple Copy			Yes		Multi Sort Copy only
3 Reduction Copy			Yes		
4 Copying Resolution dpi x lpi (dot / mm x lines / mm)			406 x 391* (16 x 15.4)		* Interpolated 16 dot/mm
<b>Certainty</b>					
1 Verification Stamp			Yes		
2 Header / Total Page Print			Yes		
3 Transaction Journal			Yes		32 Transactions / with View Mode
4 Comm. Journal			Yes		With Image
5 Last Ind. XMT Journal			Yes		
6 Power Failure Report			No		
<b>List Printouts</b>					
1 One-Touch List			Yes		
2 ABBR. No. List			Yes		
3 Program List			Yes		
4 Directory Search List			Yes		
5 Fax Parameter List			Yes		
6 File List			Yes		With View Mode
7 Ind. XMT Journal			Yes		
8 Directory Sheet			Yes		
9 Character Code List			No		
<b>Identifications</b>					
1 Logo			Yes		25 Characters
2 Multiple Logo			No		
3 Character ID			Yes		16 Characters
4 Numeric ID			Yes		20 Digits

Items	Description				Remarks
	UF-5100	UF-580/ 780	UF-6000/ 6100	UF-590/ 790	
<b>Special Communications</b>					
1 Password XMT / RCV		Yes			Closed Network
2 Selective Reception		Yes			TSI Check
3 Relay XMT Request		No			Network (Via a Center Station)
4 Relay XMT Center		No			
5 Confidential XMT / Polling		No			
6 Confidential Center		No			
7 Mailbox XMT / Polling		Yes			
8 Mailbox Center		10 Boxes			
9 File XMT		No			
10 Fax Forward		Yes			Received File Transfer
11 Auto Fax Archive		Yes			NYSE Feature Specified Destinations only
12 Sub-Address XMT		Yes			T. Routing
13 Sub-Address RCV		No			T. Routing with PC interface
14 OMR-XMT		No			
<b>Others</b>					
1 Access Code		Yes			
2 PIN Code Access		Yes			For USA / Canada / Hong Kong only PBX Access Code
3 Intelligent Redial (AI)		Yes			2 Files
4 Department Code		No			
5 Energy Saver Mode		Yes			
6 Daylight Saving Time		Yes			USA, Canada and Germany only
7 Self Diagnostic Function		Yes			
8 Remote Diagnostic Function		Yes			Specified Destinations only
9 Check & Call Function		Yes			
<b>Firmware Update / Download</b>					
1 Remote Update		Yes			Using G3 Protocol
2 Local Update					
Memory Card (FROM)		Yes			
	Parallel Port	No		Yes	
3 Download to FROM Card		Yes			

## 1.2. Printer Function

Items	Description		Remarks
	UF-580/780 UF-5100	UF-590/790 UF-6000/6100	
<b>Interface</b>			
1 Centronics Parallel I/F (IEEE-1284)	No	Standard*	*ECP Mode
2 LAN (Network)	No		
3 USB Port	No		
4 IEEE-1394	No		
<b>Printer Function</b>			
1 Printing Size	No	Letter / A4 / Legal	
2 Bypass	No		
3 Stapling	No		
4 Printing Resolution	No	600 dpi	
5 OS	-	Win 98 / Me / NT 4.0 / 2000 / XP / 2003	Windows Server 2003: (UF-6000/6100 only)
6 GDI	No	Yes	MH Coding
7 PDL (PCL6)	No		
8 PDL (PostScript 2)	No		
9 Duplex Printing	No		
10 Collation Stack	No	Yes	Printer Driver setting
11 Status Monitor	No	Yes	Local Connection
12 Network Printing	No		
13 Network Status Monitor	No		
14 Smoothing	No		
15 Applicable PC	No	IBM PC, AT or Compatible	
16 Multi-Task Operation			
Printing while Fax-XMT from Memory	No	Yes	
Printing while Fax-RCV into Memory	No	Yes	
Fax-XMT from Memory while Printing	No	Yes	
Fax-RCV into Memory while Printing	No	Yes	
17 Output to Separate Tray for Printing, Fax, Copy	No		
18 Font	No		
19 Security Print	No		
<b>Scanning Function</b>			
1 Halftone	No	Yes	64 Level Error Diffusion
2 Scanning Width	No	8.3 in (212 mm)	Letter size for USA and Canada
	No	8.2 in (208 mm)	A4 size for Other Destinations
3 Scanning Resolution	No	400 dpi*	* Interpolated

Items	Description		Remarks
	UF-580/780 UF-5100	UF-590/790 UF-6000/6100	
4 Driver	No	TWAIN	
5 2-Sided Scanning	No		

### 1.3. External View

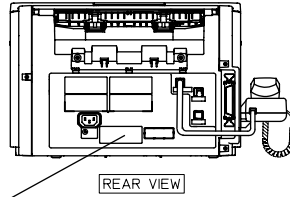

(For USA Only)

Complies with FDA radiation performance standards, 21 CFR Subchapter J

Manufacturer's Name and Address  
Factory ID

**CAUTION :** CLASS 3B INVISIBLE LASER RADIATION WHEN OPEN AND INTERLOCKS DEFEATED. AVOID EXPOSURE TO THE BEAM.  
**ATTENTION :** Rayonnement laser classe 3B invisible en cas d'ouverture et de défaut de sécurité. EXPOSITION DANGEREUSE AU FAISCEAU.  
**Vorsicht :** Um bei geöffnetem Deckel den Austritt von Klasse 3B unsichtbare Laserstrahlung zu verhindern, muss die Stromversorgung des Lasers unterbrochen werden.  
**PRECAUCIÓN :** RADIACIÓN LÁSER DE CLASE 3B INVISIBLE CUANDO SE ABRE LA PUERTA CON EL BLOQUEO INVALIDADO. EVITE LA EXPOSICIÓN A LOS RAYOS.  
**VAROITUS :** LUOKKA 3B NÄKYMÄTÖNTÄ JA VAARALLISTA LASERSÄTEILYÄ, JOS LAITTEEN KANSI AVATAAN KESKEN SKANNAUKSEN JA SUOJALUKITUS OHITETAAN. VÄLTÄ SUORAA ALTISTUMISTA SÄTEELLE.  
**ADVARSEL :** KLASSE 3B USYNLIG LASERSTRÅLING NÅR ÅBEN OG SIKKERHEDSLÅS BRYDES. UNDGÅ EKSPONERING FOR STRÅLEN.  
**ADVARSEL :** KLASSE 3B USYNLIG LASERSTRÅLING NÅR MASKINEN ER ÅPEN OG SIKKERHETSLÅS BRYTES. UNNGÅ EKSPONERING FOR STRÅLEN.  
**WARNING :** CLASS 3B OSYNLIG LASER ÖPPEN OCH NÅR SÄKERHETSPÅRRAR ÅR URKOPPLADE. UNDVIK EXPONERING AV LASER  
**注意 :** 当打开本机及连锁装置失效时, 为防止CLASS 3B不可见激光照射, 请勿暴露在光柱下。  
**주의 :** 커버(덮개)가 열려 있거나 인터락이 파손된 경우 눈에 보이지 않는 클래스3B의 레이저 광선이 유출 될 수 있습니다. 레이저 광선에 노출되지 않도록 주의 하십시오. FBS8932B

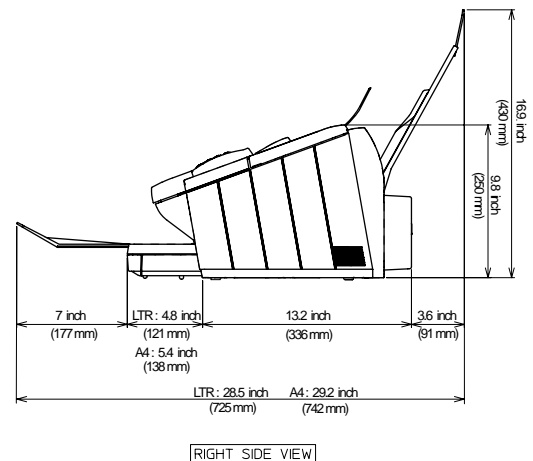
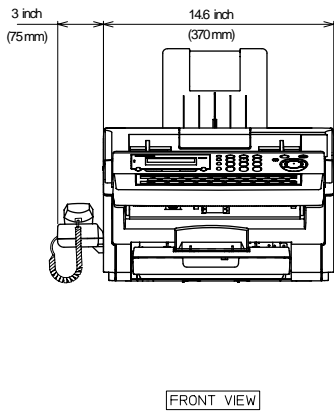
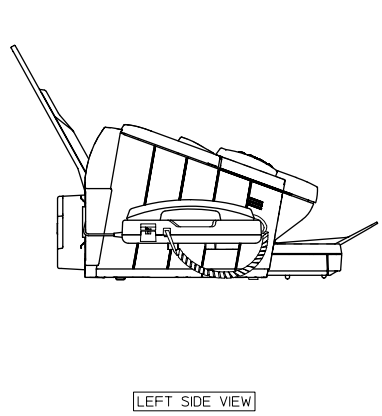
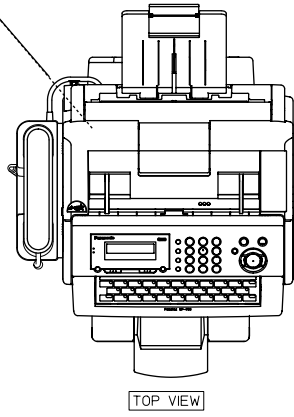

### 1.3.1. Serial Number Contents

The contents of the 11-digit Serial Number is as follows:

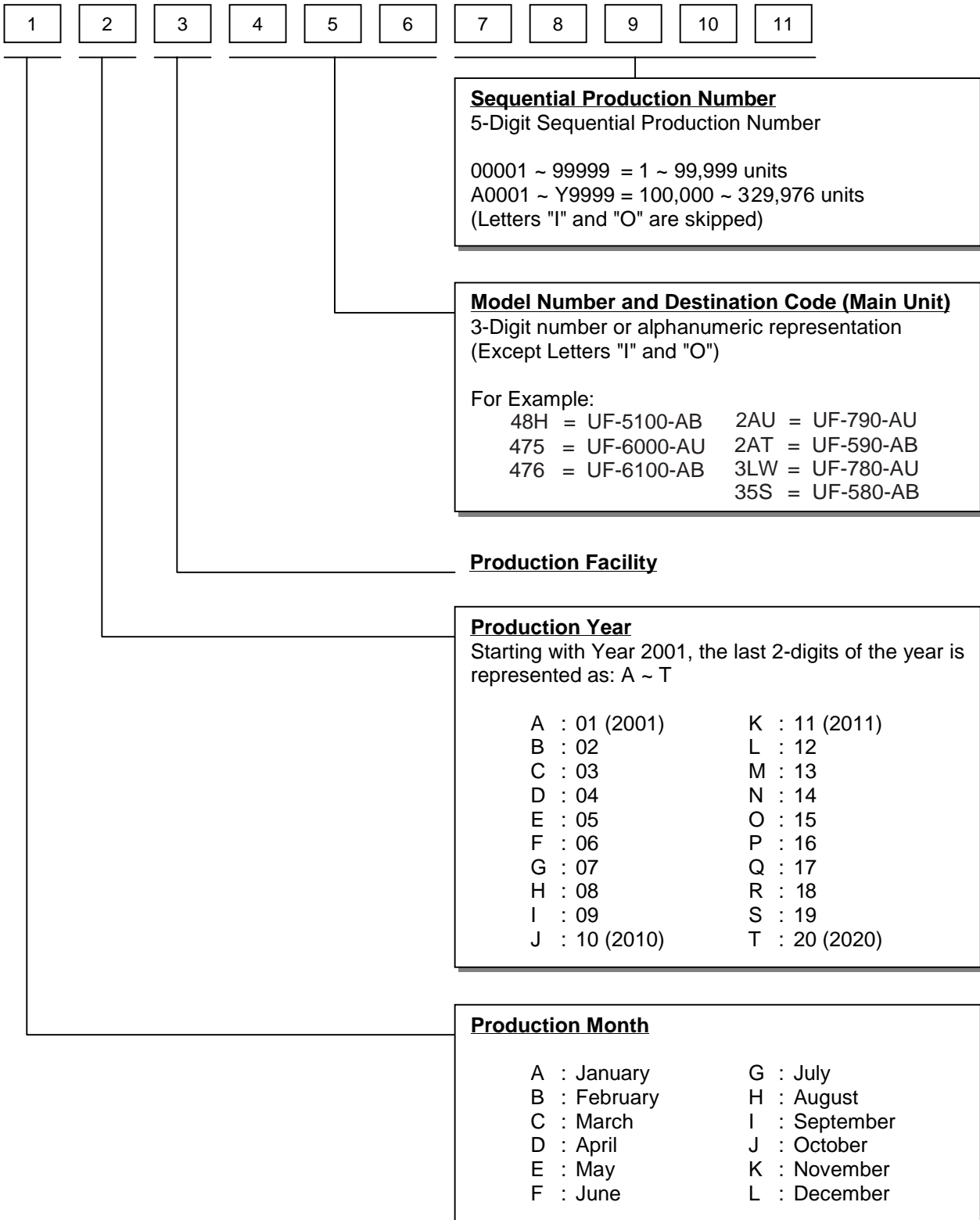

# 1.4. Control Panel

For USA and Canada

- UF-780/790

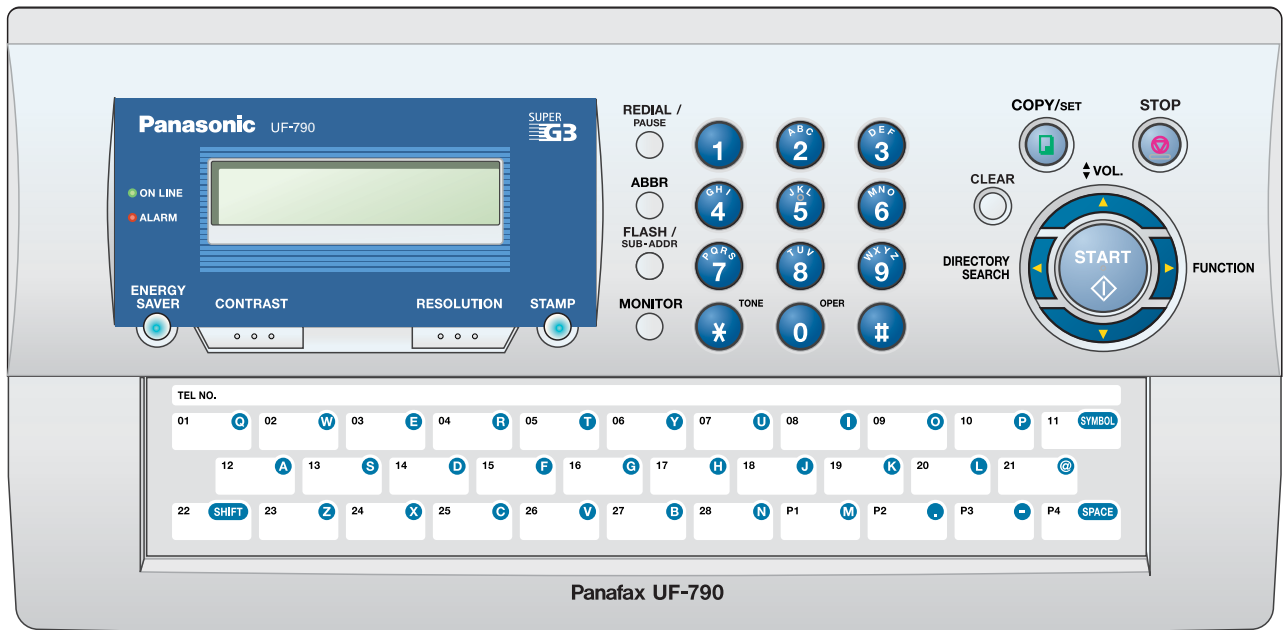

- UF-6000



## For Other Destinations

### • UF-580/590

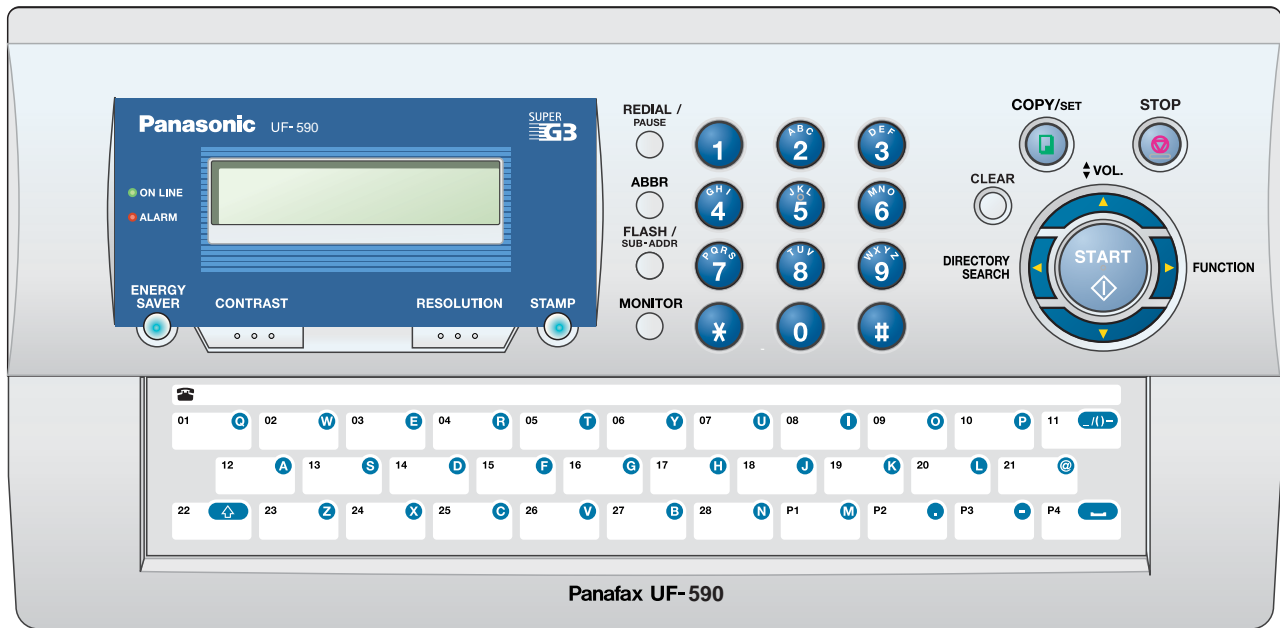

### • UF-5100/6100





# 2 Disassembly Instructions

## 2.1. General Disassembly Flowchart

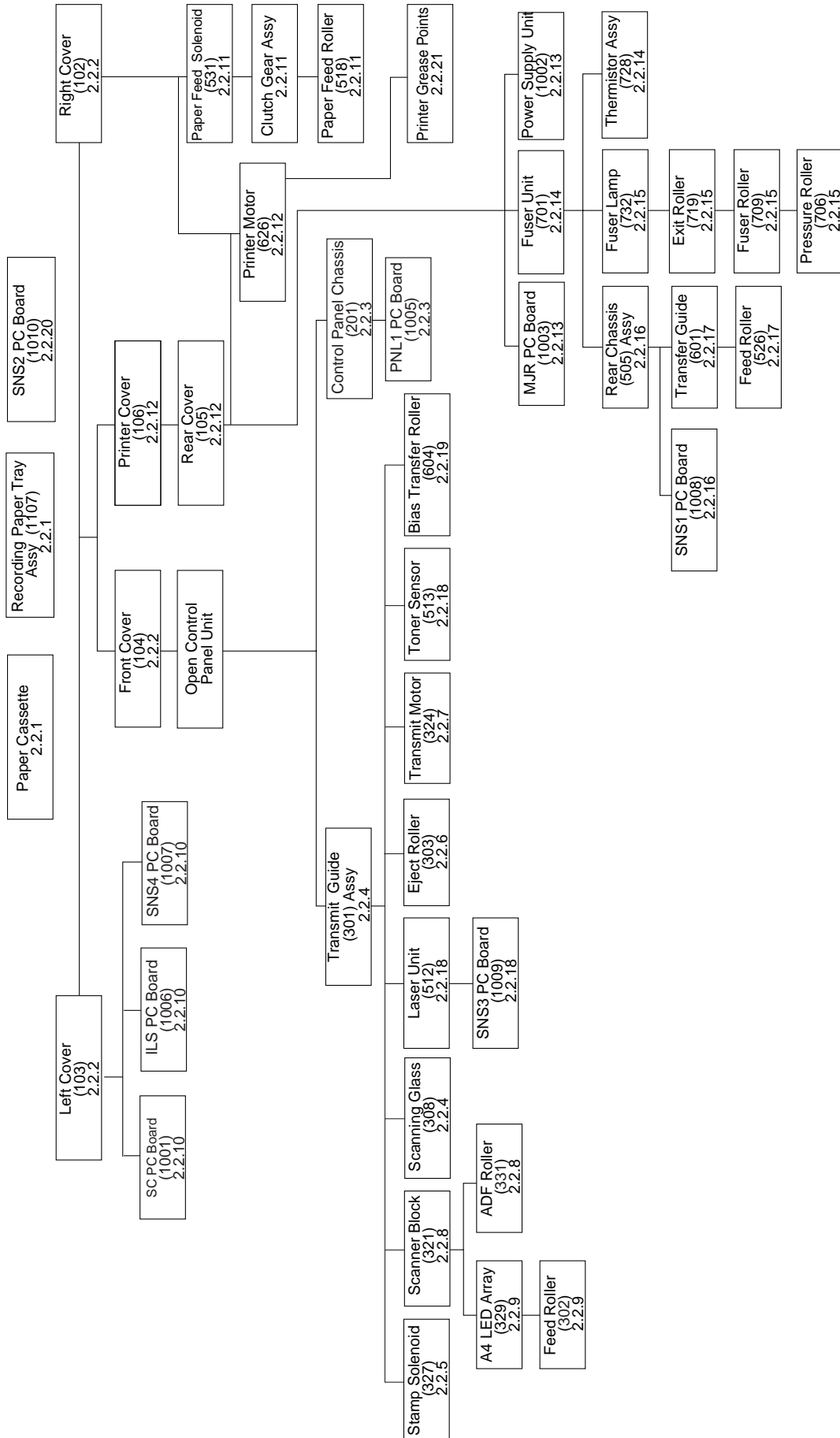

## 2.2. Disassembly Instructions

### 2.2.1. Power Cord (1108), Telephone Line Cable (1109), Recording Paper Tray Assembly (1107), Paper Cassette

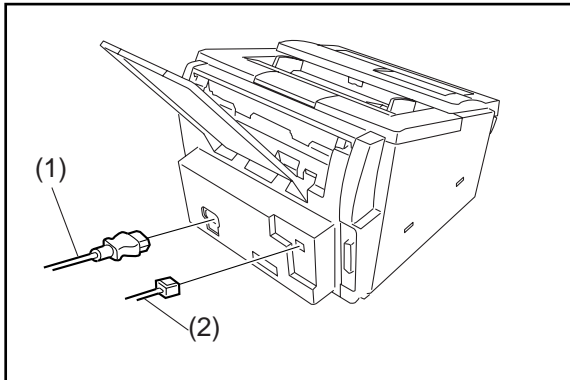

- (1) Disconnect the **Power Cord** (1108).
- (2) Disconnect the **Telephone Line Cable** (1109).

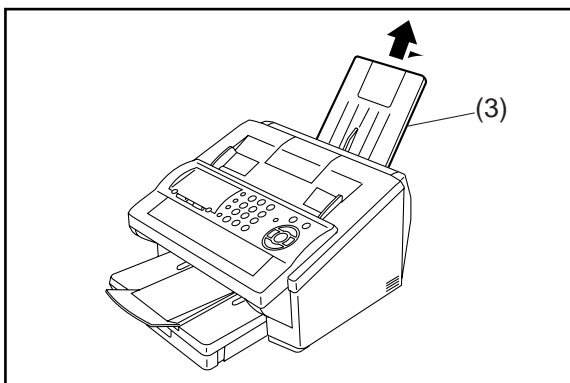

- (3) Remove the **Recording Paper Tray Assembly** (1107).

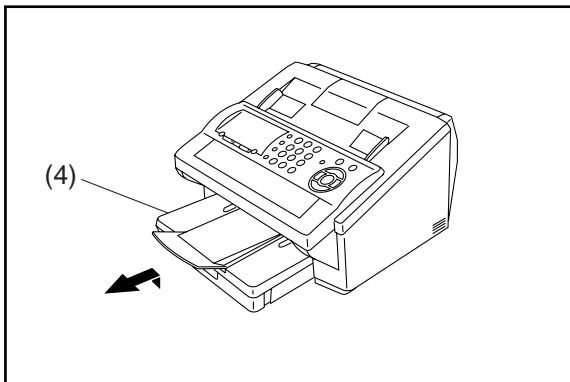

- (4) Remove the **Paper Cassette**.

## 2.2.2. Left Cover (103), Right Cover (102), Front Cover (104), Speaker (117), Separation Rubber (207)

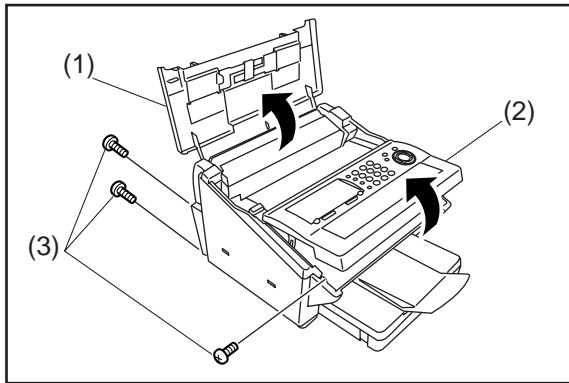

- (1) Open the **Printer Cover** (106).
- (2) Open the **Control Panel Unit**.
- (3) Remove 3 **Silver Screws** (B1).

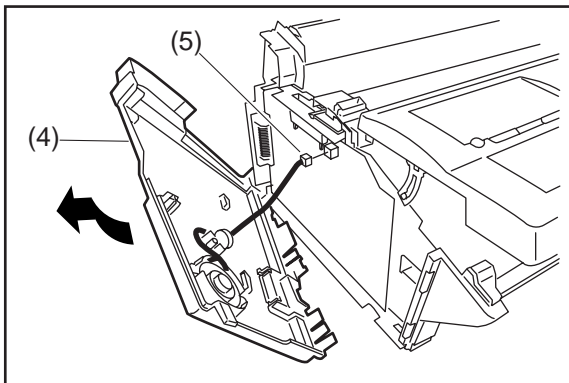

- (4) Remove the **Left Cover** (103).
- (5) Disconnect **Connector CN9** on the **SC PC Board** (1001).

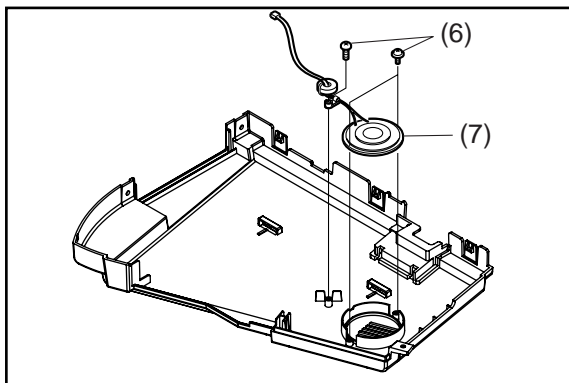

- (6) Remove 2 **Screws** (C2) and 1 **Screw** (1Y).
- (7) Remove the **Speaker** (117).

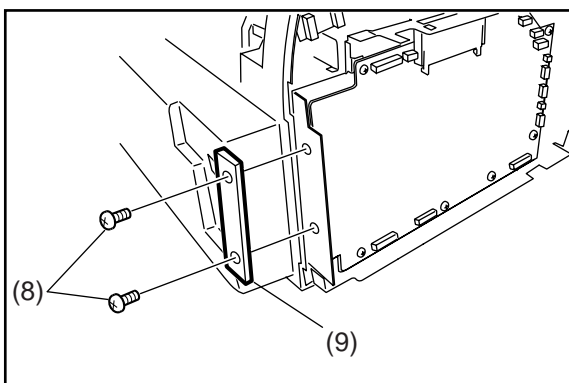

<The following steps (8) and (9) are available for UF-580/780/5100 only>

- (8) Remove 2 **Silver Screws** (B1).
- (9) Remove the **SNT Cover** (131).

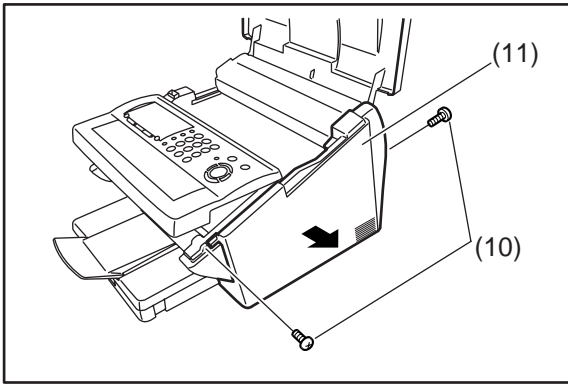

- (10) Remove 2 **Silver Screws** (B1).
- (11) Remove the **Right Cover** (102).

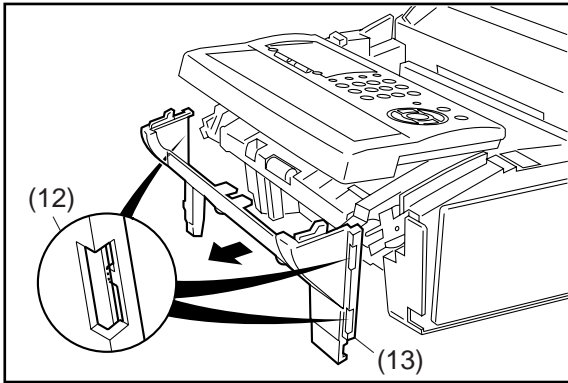

- (12) Release 3 **Latch Hooks**.
- (13) Remove the **Front Cover** (104).

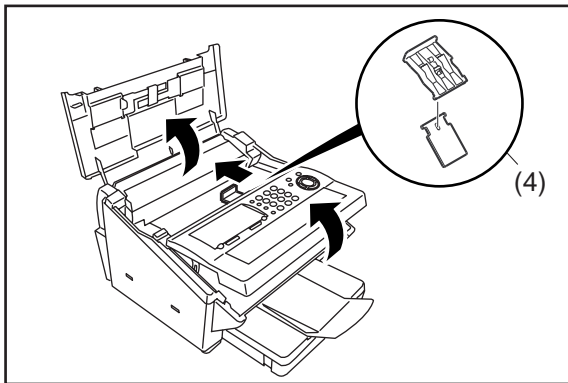

**<Replacing & Cleaning Separation Rubber>**

- (1) Open the Control Panel Unit.
- (2) Open the **Printer Cover** (106).
- (3) Remove the **Separation Rubber Holder Assy** (202).
- (4) Replace with a new **Separation Rubber** (207).
- (5) Clean the **Separation Rubber** (207) with a soft cloth, soaked with isopropyl alcohol.

### 2.2.3. Control Panel Unit, PNL1 PC Board (1004)

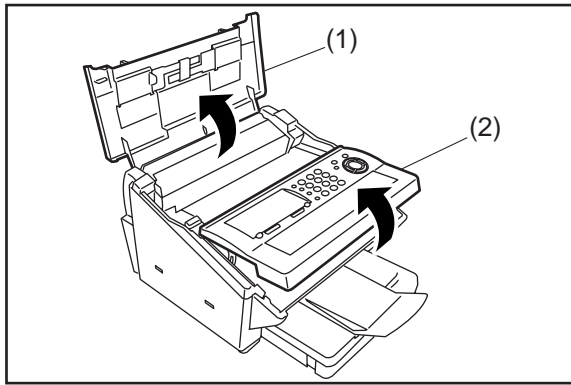

- (1) Open the **Printer Cover** (106)
- (2) Slightly open the **Control Panel Unit**.

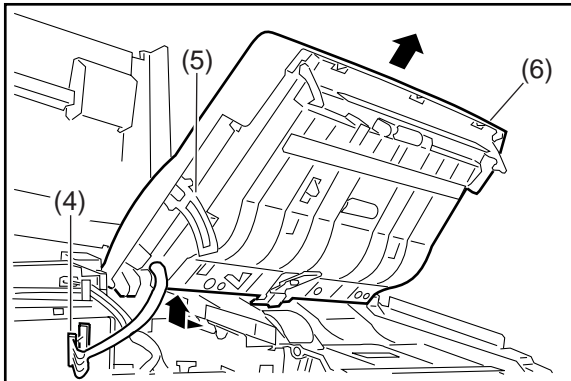

- (3) Remove the **Left Cover** (103) and the **Right Cover** (102). (Refer to 2.2.2.)
- (4) Disconnect **Connector CN14** on the **SC PC Board**.
- (5) Release the **Stopper Latch** (210) and open the **Control Panel Unit**.
- (6) Remove the **Control Panel Unit**.

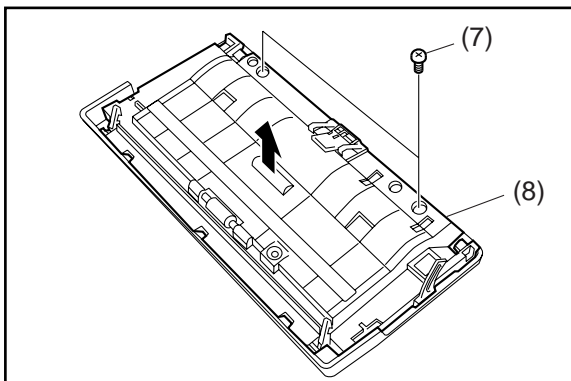

- (7) Remove 2 **Screws** (19).
- (8) Remove the **Control Panel Chassis** (201) **Assembly**.

**Note:**

If noise occurs while scanning, clean the **Roller Shaft 2** (235) and the **Feed Pinch Roller** (236) shaft hole with isopropyl alcohol.

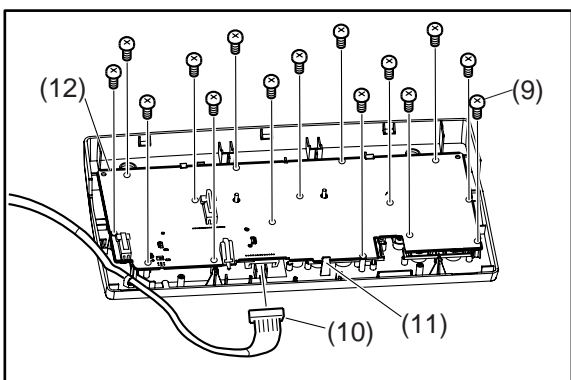

- (9) Remove 15 **Screws** (7B).
- (10) Disconnect **Connector CN50** on the **PNL1 PC Board**.
- (11) Release 1 **Latch Hook**.
- (12) Remove the **PNL1 PC Board** (1004).

## 2.2.4. Transmit Guide (301) Assembly, Scanning Glass (308)

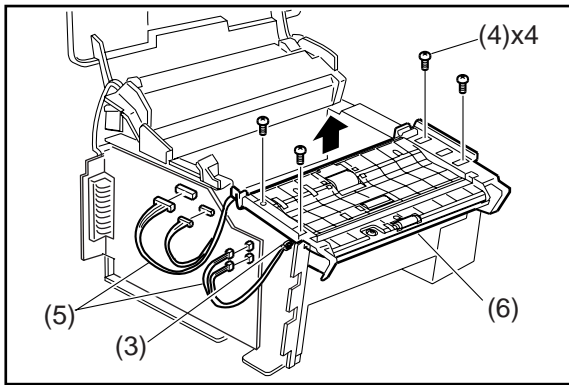

- (1) Remove the **Left Cover** (103), **Right Cover** (102), and **Front Cover** (104) (Refer to 2.2.2.).
- (2) Remove the **Control Panel Unit** (Refer to 2.2.3.).
- (3) Release the Harnesses from the clamps.
- (4) Remove 4 **Screws** (19).
- (5) Disconnect 4 **Connectors** (CN1, 3, 5 and 7) on the **SC PC Board**.
- (6) Remove the **Transmit Guide** (301) **Assembly**.

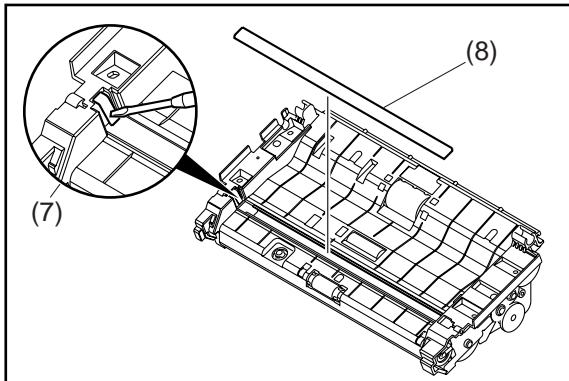

- (7) Carefully release the Latch Hook using a Blade-tip Screwdriver.
- (8) Remove the **Scanning Glass** (308).

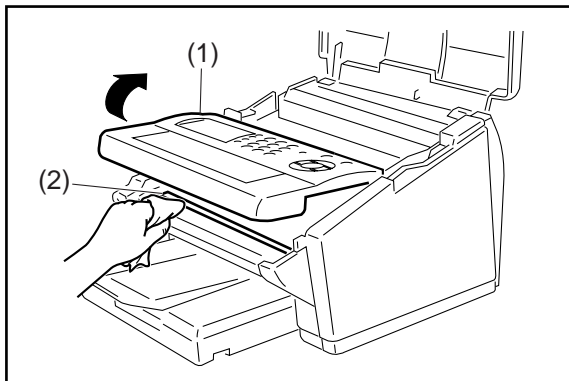

### <Cleaning Scanning Glass>

- (1) Open the Control Panel Unit.
- (2) Clean the **Scanning Glass** (308) with a soft cloth, soaked with isopropyl alcohol.

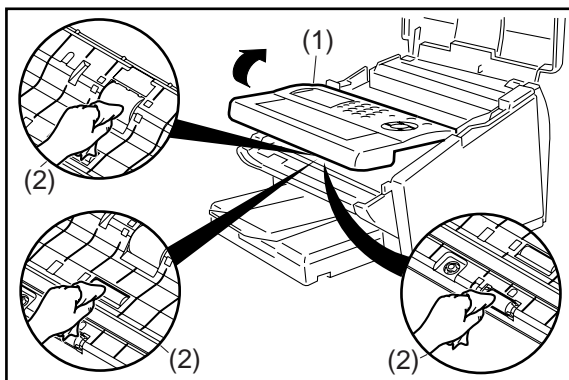

### <Cleaning Feed Roller, Eject Roller, ADF Roller>

- (1) Open the Control Panel Unit.
- (2) Clean the **Feed Roller** (302), **Eject Roller** (303) and **ADF Roller** (331) with a soft cloth, soaked with isopropyl alcohol.

## 2.2.5. Stamp Assembly, Stamp Solenoid (327)

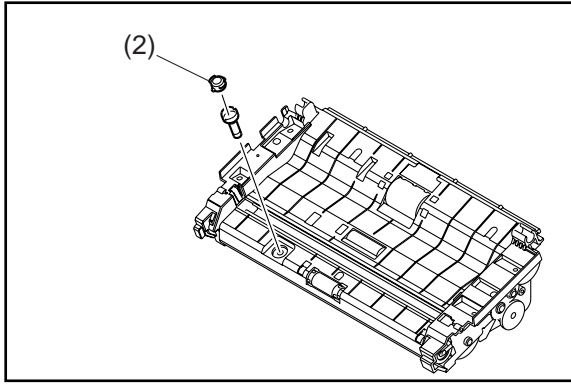

- (1) Remove the **Transmit Guide (301) Assembly** (Refer to 2.2.4.).
- (2) Remove the **Stamp Assembly (325, 326)**.

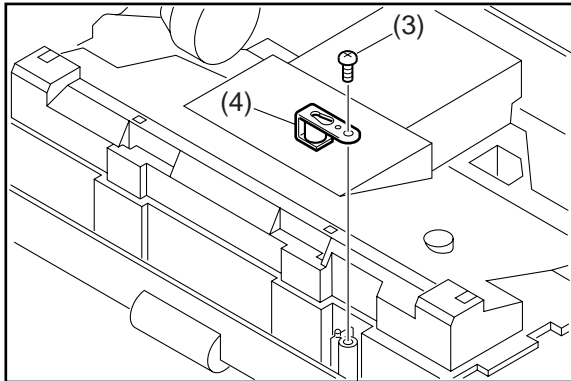

- (3) Remove 1 **Screw (19)**.
- (4) Remove the **Stamp Solenoid (327)**.

## 2.2.6. Eject Roller (303)

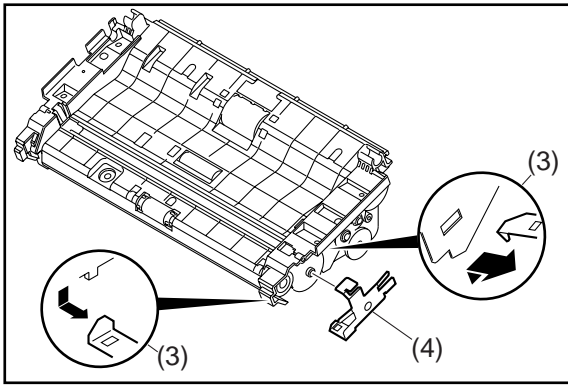

- (1) Remove the **Transmit Guide (301) Assembly** (Refer to 2.2.4.).
- (2) Remove the **Stamp Assembly (325, 326)** (Refer to 2.2.5.).
- (3) Release 2 Latch Hooks.
- (4) Remove the **Ground Plate (317)**.

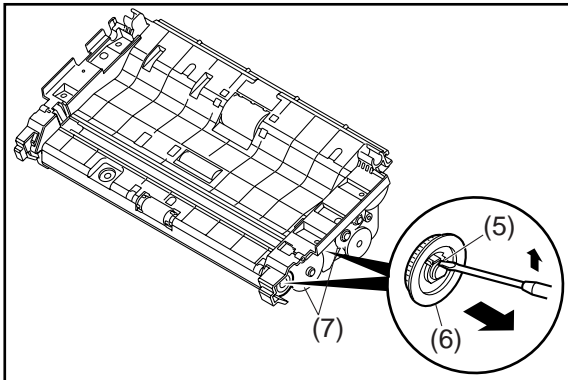

- (5) Release the Latch Hook by using a small Blade-tip Screwdriver.
- (6) Remove 2 **D25F Drive Gears (332)**.
- (7) Remove **D17 Gear (313)** and **D50 Gear (314)**.

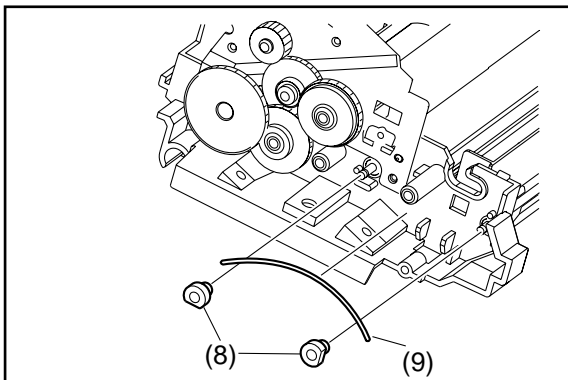

- (8) Remove 2 **P6C Bushings (342)**.
- (9) Remove the **Roller Wire Spring (343)**.

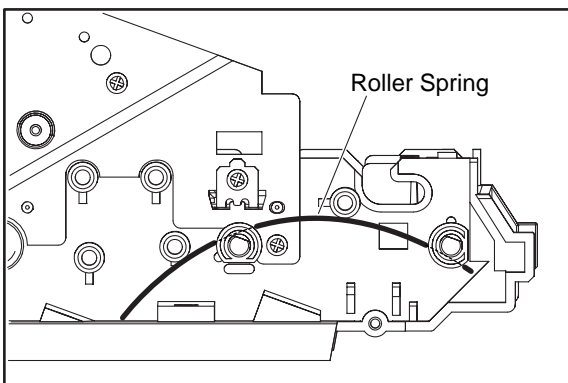

**Caution:**  
Reinstall the Roller Wire Spring (343) as illustrated.



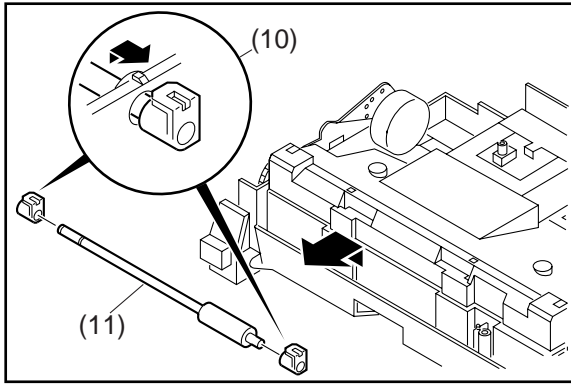

- (10) Remove 2 **P6A Bushings** (316).
- (11) Remove the **Eject Roller** (303).

## 2.2.7. Transmit Motor (324)

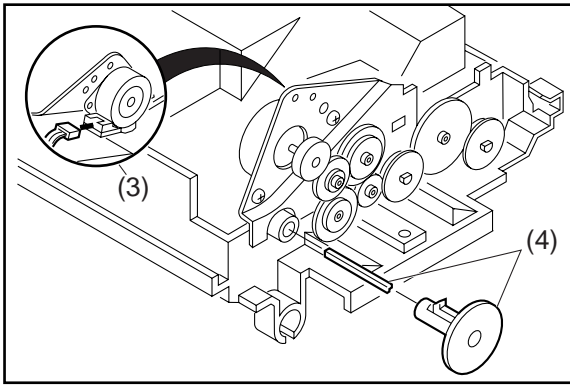

- (1) Remove the **Transmit Guide (301) Assembly** (Refer to 2.2.4.).
- (2) Remove the **Stamp Assembly (325, 326)** (Refer to 2.2.5.).
- (3) Disconnect the **Connector (1020)** from the **Transmit Motor (324)**.
- (4) Remove the **ADF Gear (305)** and **ADF Angular Shaft (338)**.

**Caution:**

When removing the ADF Gear, rotate the Transmit Motor Gear by hand until the Gear Latch Hook can be seen from the inside, under the Transmit Motor. Push down on the Latch Hook to release the ADF Gear.

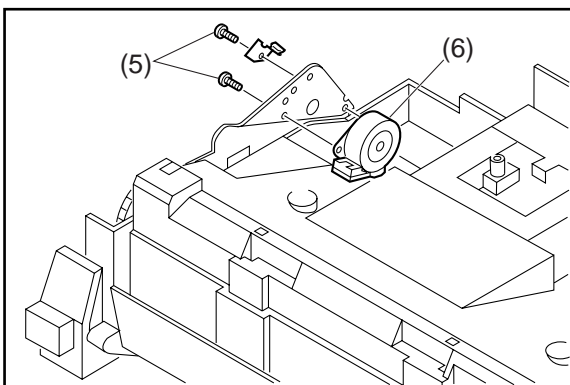

- (5) Remove 2 **Screws (19)**.
- (6) Remove the **Transmit Motor (324)**.

**Caution:**

Reinstall the Transmit Motor (324) as illustrated.

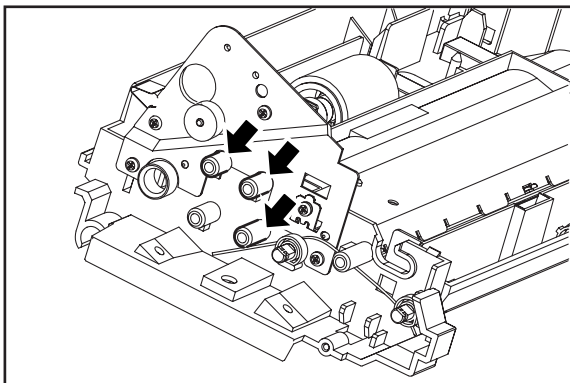

**Caution:**

Before reassembling, apply EM-50L Grease to the Gear Posts as illustrated.

## 2.2.8. Scanner Block (321), Mirror 1 (334), Mirror 2 (335), Mirror 3 (336), ADF Roller (331)

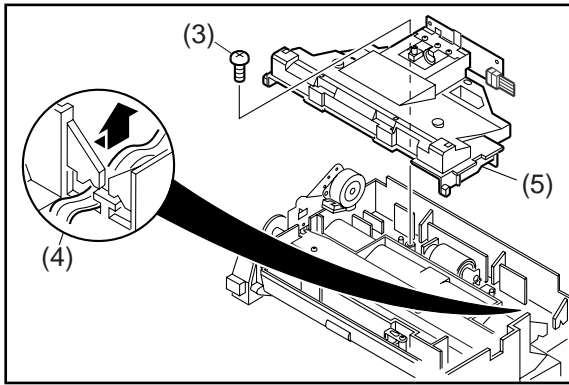

- (1) Remove the **Transmit Guide (301) Assembly** (Refer to 2.2.4.).
- (2) Remove the **Stamp Assembly (325, 326)** (Refer to 2.2.5.).
- (3) Remove 1 **Screw (19)**.
- (4) Remove the Harnesses from the hook.
- (5) Remove the **Scanner Block (321)**.

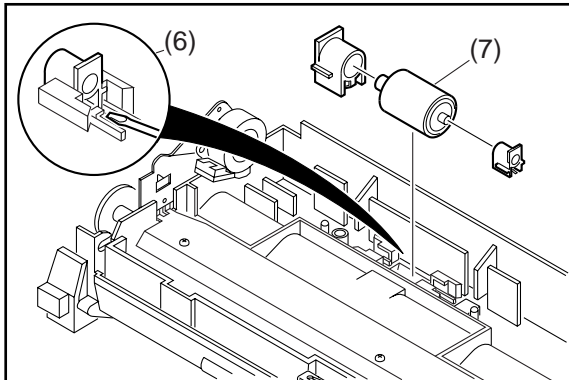

- (6) Remove **P10 and P6B Bushings (315, 318)** by using Blade-tip Screwdriver.
- (7) Remove the **ADF Roller (331)**.

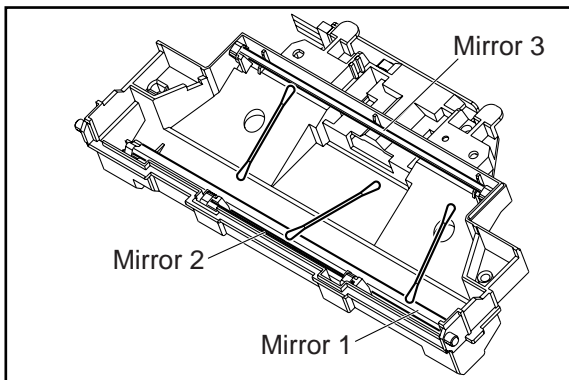

### <Cleaning Mirror 1, Mirror 2 and Mirror 3>

Clean **Mirror 1 (334)**, **Mirror 2 (335)** and **Mirror 3 (336)** with a soft cloth, soaked with isopropyl alcohol.

## 2.2.9. LED Array (329), Feed Roller (302)

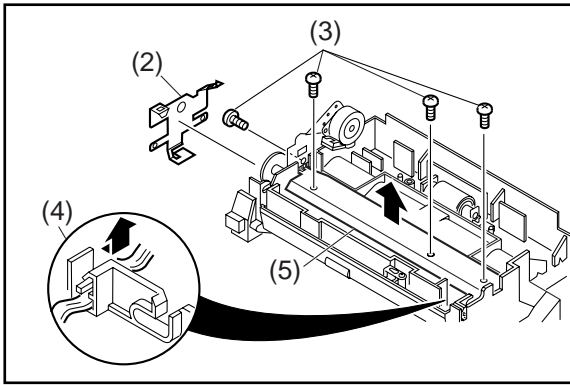

- (1) Remove the **Scanner Block** (321)  
(Refer to 2.2.8.).
- (2) Remove the **Ground Plate** (317).
- (3) Remove 4 **Screws** (19).
- (4) Release the Harness from the hook.
- (5) Remove the **LED Bracket** (306) **Assembly**.

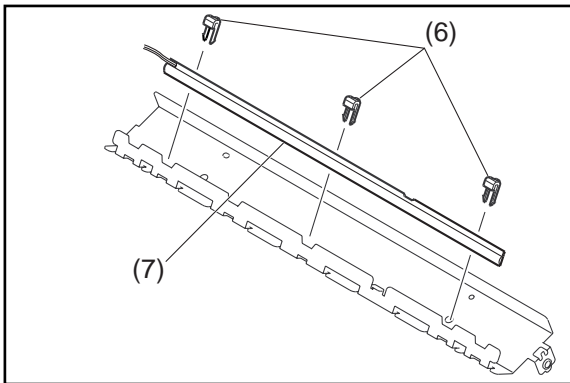

- (6) Remove 3 **LED Clips** (307).
- (7) Remove the **LED Array** (329).

### **Caution:**

When reinstalling the LED Array, position the 3 LED Clips at the appropriate locations.

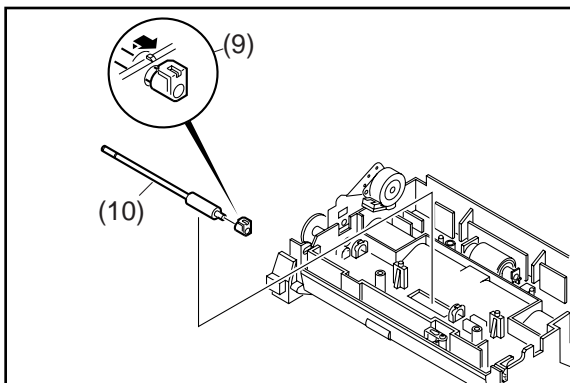

- (8) Remove the **Gears, Bushings** and the **Roller Wire Spring** (Refer to 2.2.6.).
- (9) Remove 2 **P6A Bushings** (316).
- (10) Remove the **Feed Roller** (302).

## 2.2.10. SC PC Board (1001), ILS PC Board (1006), SNS4 PC Board (1007)

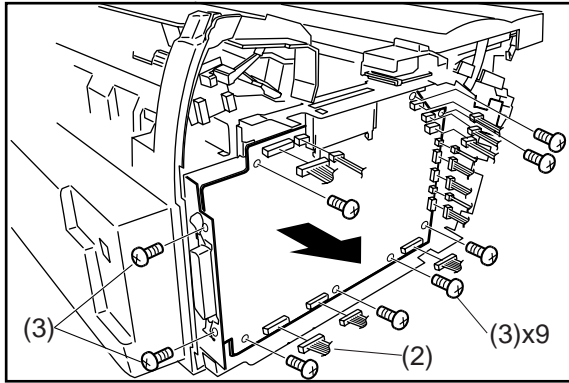

- (1) Remove the **Left Cover** (Refer to 2.2.2.).
- (2) Disconnect all **Connectors** on **SC PC Board**.
- (3) Remove 9 **Screws** (19).  
(7 Screws for UF-580/780)
- (4) Remove the **SC PC Board** (1001).

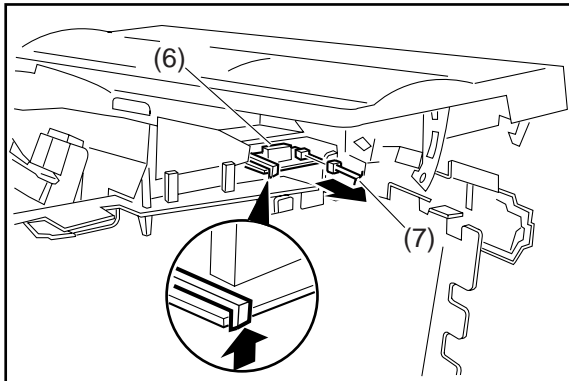

- (5) Move all **Harnesses** away from the front of the **Door Sensor**.
- (6) Release the **Latch Hook** and remove the **ILS PC Board** (1006).
- (7) Disconnect **Connector CN73** on the **ILS PC Board** (1006).

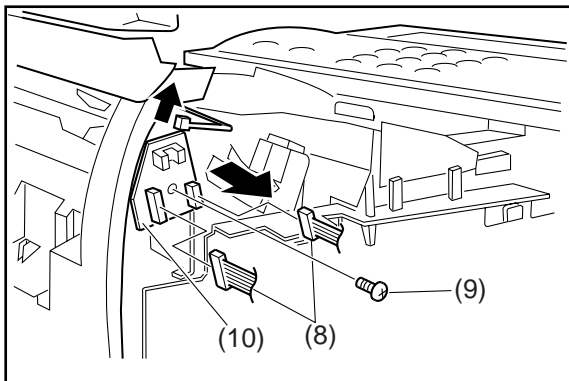

- (8) Disconnect **Connectors CN85** and **87** on the **SNS4 PC Board**.
- (9) Remove 1 **Screw** (19).
- (10) Lift up the **Paper Exit Actuator** (730) and remove the **SNS4 PC Board** (1007).

## 2.2.11. Paper Feed Solenoid (531), Clutch Gear Assembly, Paper Feed Roller (518)

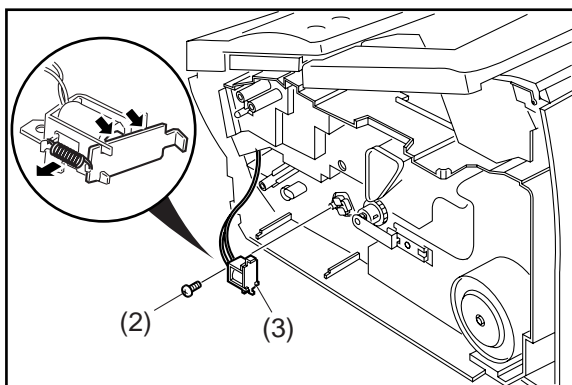

- (1) Remove the **Right Cover** (102) (Refer to 2.2.2.).
- (2) Remove 1 **Screw** (19).
- (3) Remove the **Paper Feed Solenoid** (531).

### Note:

If the Paper Feed Solenoid does not work properly due to dust, etc. Remove the spring to disassemble and clean the magnet and plate as illustrated.

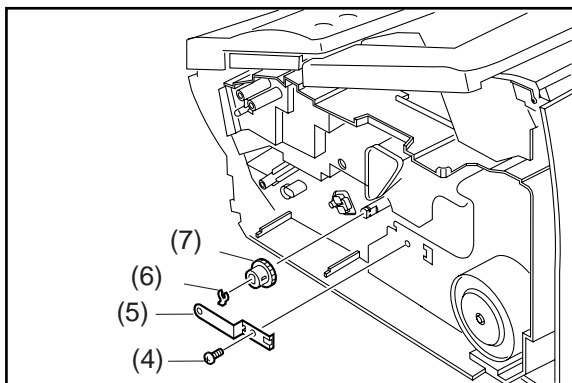

- (4) Remove 1 **Screw** (19).
- (5) Remove the **Feed Roller Ground Spring** (628).
- (6) Remove the **Snap Ring** (B9).
- (7) Remove the **Clutch Gear Assembly**.

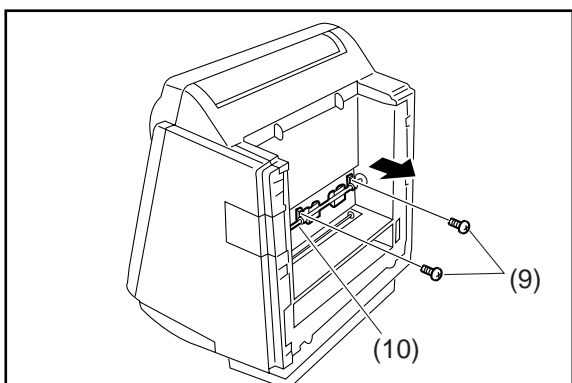

- (8) Place the machine on its Rear side.
- (9) Remove 2 **Screws** (19).
- (10) Remove the **Feed Roller Assembly**.

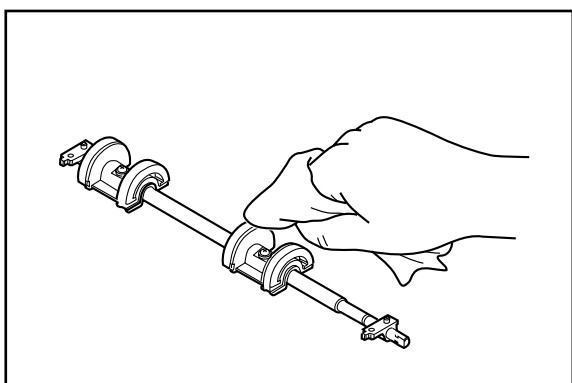

Clean the **Paper Feed Rollers** (518) with a soft cloth, soaked with isopropyl alcohol.

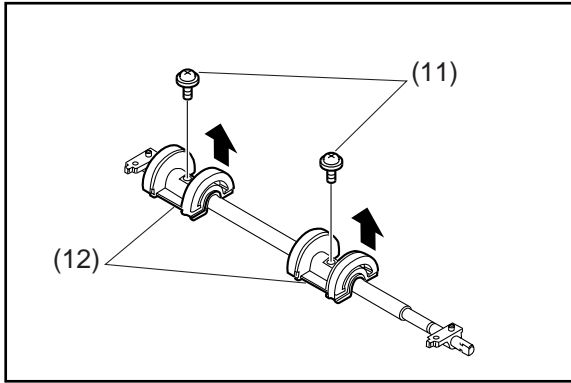

(11) Remove 2 **Screws** (4N).

(12) Remove the **Paper Feed Rollers** (518).

## 2.2.12. Printer Cover (106), Rear Cover (105), Printer Motor (626)

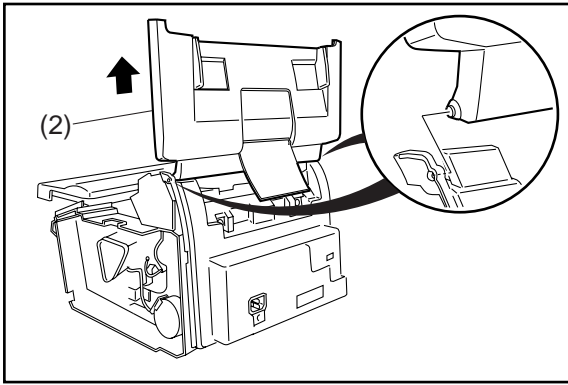

- (1) Remove the **Left Cover** and the **Right Cover** (Refer to 2.2.2.).
- (2) Release the hooks and remove the **Printer Cover (106)**.

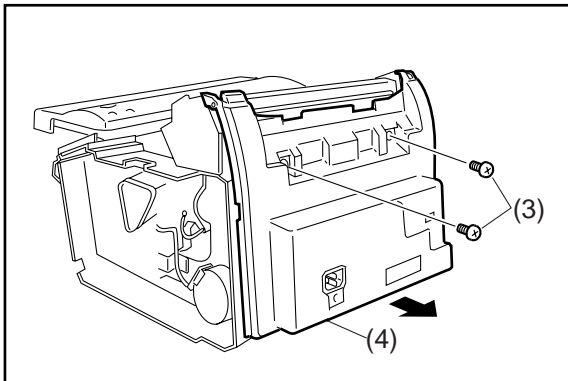

- (3) Remove 2 **Silver Screws (B1)**.
- (4) Remove the **Rear Cover (105)**.

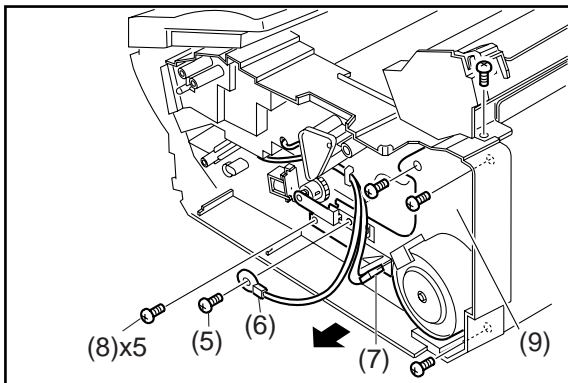

- (5) Remove 1 **Screw (19)**.
- (6) Remove the **Ground Wire (542)**.
- (7) Disconnect the **Connector** from the **Printer Motor**.
- (8) Remove 5 **Screws (19)**.
- (9) Remove the **Printer Motor Bracket (616) Assembly**.

### **Caution:**

The Gears underneath may dislodge when the Motor Bracket is removed.

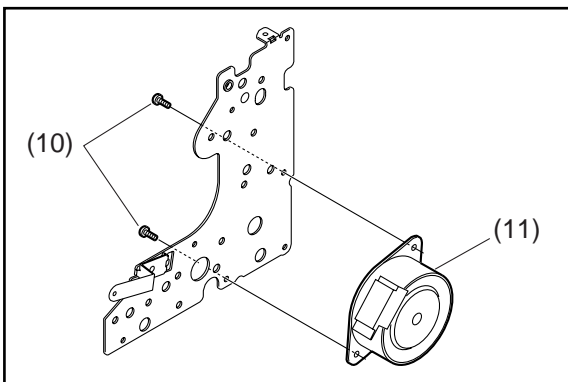

- (10) Remove 2 **Screws (4N)**.
- (11) Remove the **Printer Motor (626)**.



### 2.2.13. MJR PC Board (1003), Power Supply Unit (1002)

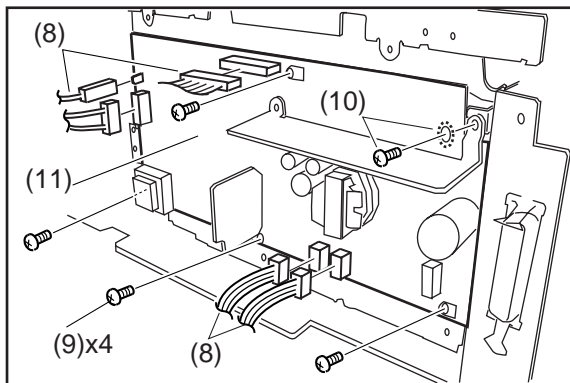
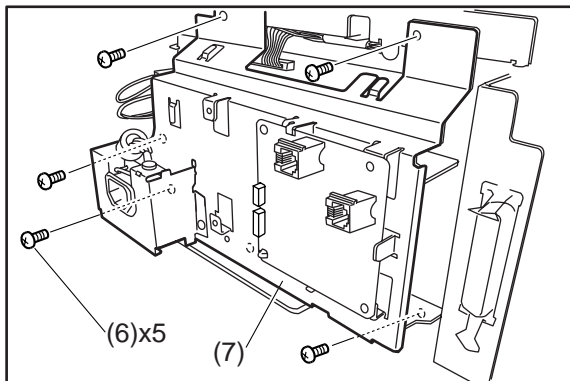
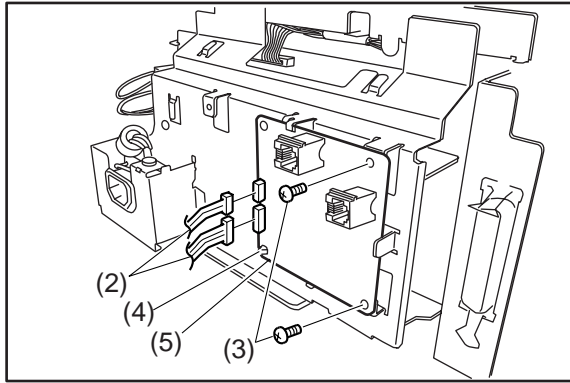

**Caution:**

Make sure the **Power Cord** (1108) is unplugged.

**Note:**

If removing only the **Power Supply Unit**, skip steps (3), (4) and (5).

- (1) Remove the **Rear Cover** (105) (Refer to 2.2.12.).
- (2) Disconnect the **Connectors** (CN28 and 29) on the **MJR PC Board**.
- (3) Remove 2 **Screws** (19).
- (4) Release the **Latch Hook of Locking Card Spacer** (405).
- (5) Remove the **MJR PC Board** (1003).
- (6) Remove 5 **Screws** (19).
- (7) Remove the **L Power Plate** (401).

- (8) Disconnect the **Connectors** (CN101, 102, 103, 201 and 202) on the **Power Supply Unit** (1002).
- (9) Remove 4 **Screws** (19).
- (10) Remove 1 **Screw** (19) and 1 **Washer** (G8).
- (11) Remove the **Power Supply Unit** (1002).

## 2.2.14. Fuser Unit, Thermistor Assembly (728)

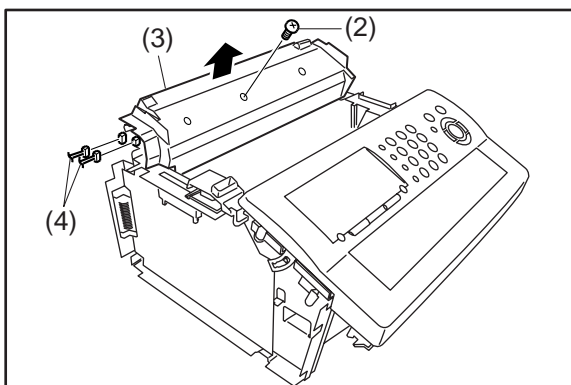

- (1) Remove the **Rear Cover** (Refer to 2.2.12.).
- (2) Remove 1 **Screw** (19).
- (3) Remove the **Fuser Top Cover** (733).
- (4) Disconnect the **Connectors CN85** and **CN87** on the **SNS4 PC Board** (1007).

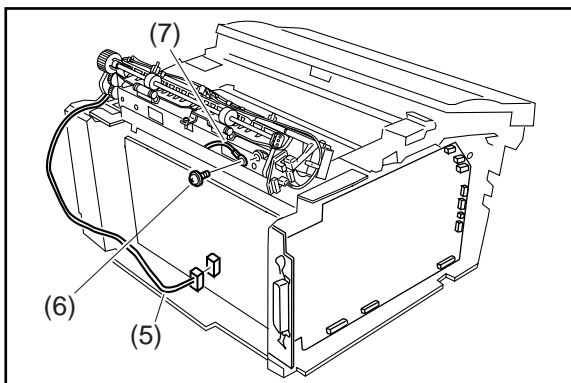

- (5) Disconnect the **Connector CN102** on the **Power Supply Unit** (423).
- (6) Remove 1 **Screw** (4N).
- (7) Remove the **FG1 Harness** (629).

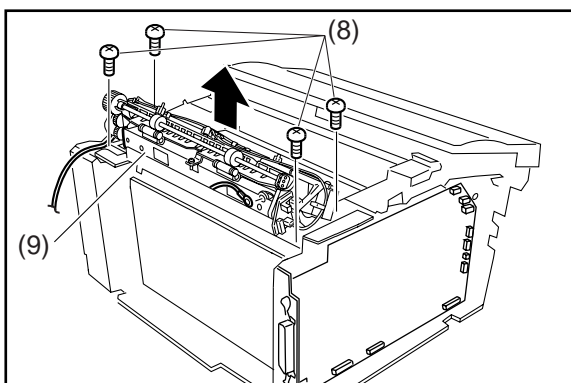

- (8) Remove 4 **Screws** (19).
- (9) Remove the **Fuser Unit**.

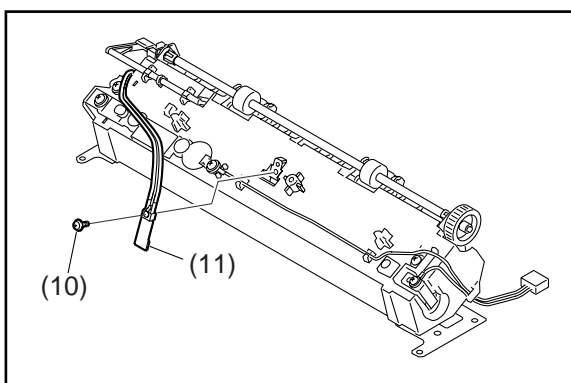

- (10) Remove 1 **Screw** (1Q).
- (11) Remove the **Thermistor Assembly** (728).

## 2.2.15. Fuser Lamp (732), Exit Roller (719), Fuser Roller (709), Pressure Roller (706)

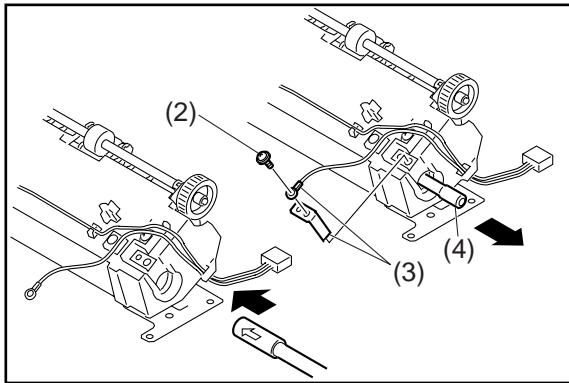

- (1) Remove the **Rear Cover** (Refer to 2.2.12.) and the **Fuser Unit** (Refer to 2.2.14.).
- (2) Remove 1 **Screw** (4N).
- (3) Remove the **PSU-Fuser Harness** (1028) and **Fuser Lamp Terminal B** (731).
- (4) Remove the **Fuser Lamp** (732).

### Caution:

When reinstalling the Fuser Lamp, make sure that the Fuser Lamp is inserted into the Fuser Unit as illustrated. Do not touch the glass portion of the Fuser Lamp with bare hands. Grease from fingerprints will shorten its life cycle, use isopropyl alcohol to clean fingerprints.

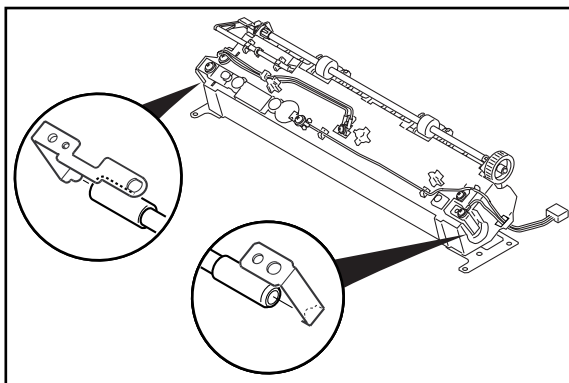

### Caution:

When reinstalling the Fuser Lamp, make sure that both ends of the Fuser Lamp fits into the projected area of the **Fuser Lamp Terminal A** (724) and the **Fuser Lamp Terminal B** (731).

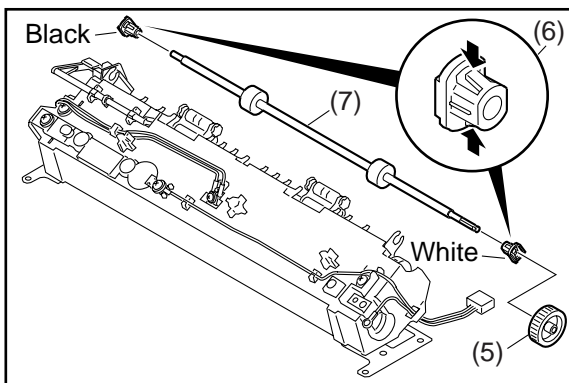

- (5) Remove the **E22 Gear** (722).

### Caution:

You may need to use force to pull out the Gear.

- (6) Remove the **Right** and **Left P3.5L11.2 Bushings** (720 and 721).
- (7) Remove the **Exit Roller** (719).

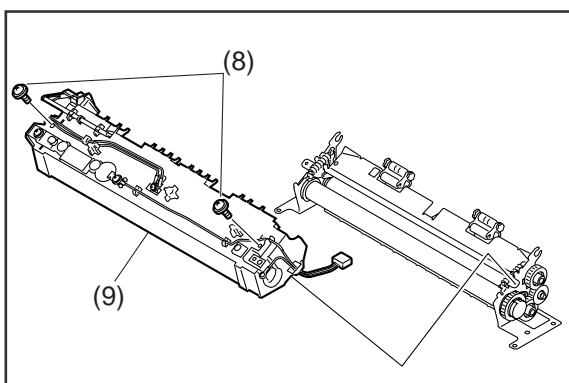

- (8) Remove 2 **Screws** (4N).
- (9) Remove the **Fuser Cover** (723).

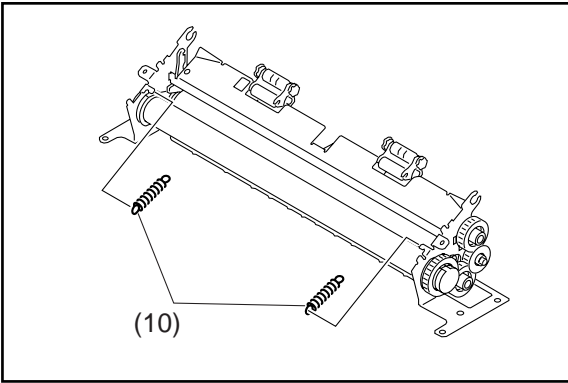

(10) Remove 2 **Pressure Springs** (708).

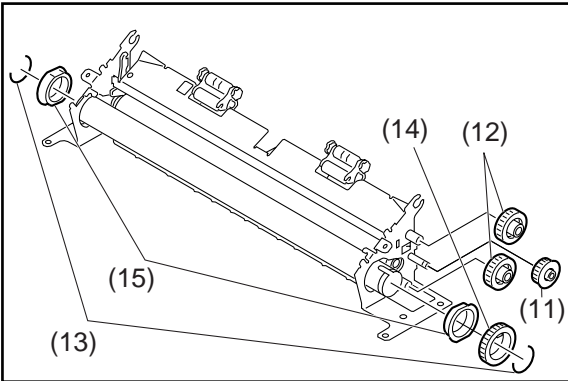

(11) Remove the **E14 Gear** (714).

**Caution:**

You may need to use force to pull out the Gear.

(12) Remove the 2 **E18 Gears** (713).

(13) Remove 2 **C-Rings** (712).

(14) Remove the **E24 Drive Gear** (711).

(15) Remove 2 **P17L6.8 Bushings** (710).

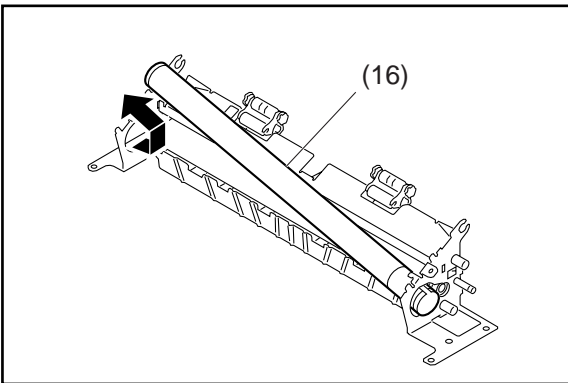

(16) Remove the **Fuser Roller** (709).

**Caution:**

Do not scratch the surface of the Fuser Roller when removing or reinstalling it.

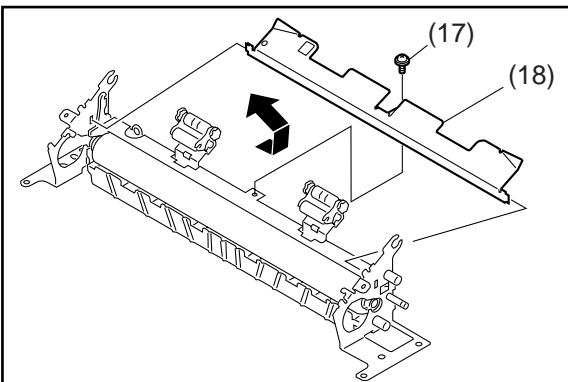

(17) Remove 1 **Screw** (4N).

(18) Remove the **Lower Paper Exit Guide** (703).

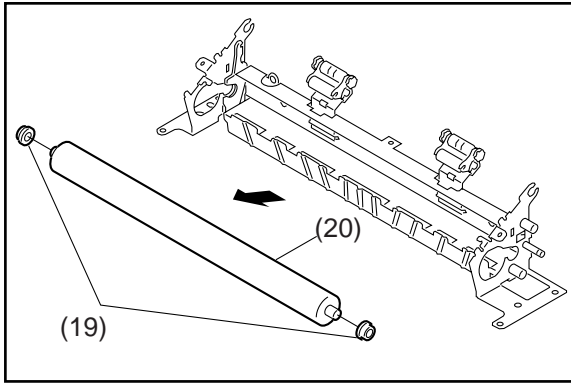

(19) Remove 2 **P6L5.5 Bushings** (707).

(20) Remove the **Pressure Roller** (706).

**Caution:**

Do not scratch the surface of the Pressure Roller when removing or reinstalling it.

## 2.2.16. Rear Chassis (505), SNS1 PC Board (1008)

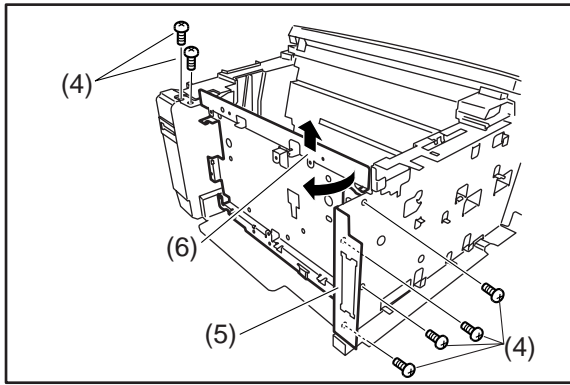

- (1) Remove the **Power Supply Unit**  
(Refer to 2.2.12.).
- (2) Remove the **SC PC Board** (Refer to 2.2.12.).
- (3) Remove the **Fuser Unit** (Refer to 2.2.14.).
- (4) Remove 6 **Screws** (19).
- (5) Remove the **Bracket** (403).
- (6) Remove the **Rear Chassis** (505).

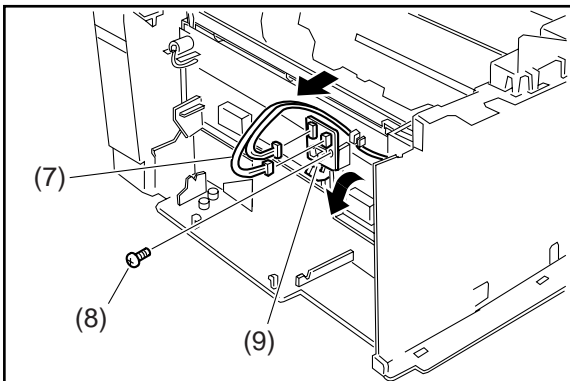

- (7) Disconnect **Connectors CN80** and **CN81** on the  
**SNS1 PC Board** (1008).
- (8) Remove 1 **Screw** (19).
- (9) Remove the **SNS1 PC Board** (1008).

## 2.2.17. Transfer Guide (601) Assembly, Feed Roller (526)

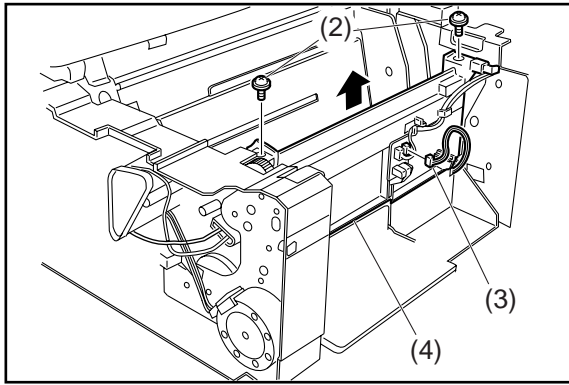

- (1) Remove the **Rear Chassis** (Refer to 2.2.16.).
- (2) Remove 2 **Screws** (C8).
- (3) Disconnect **Connector CN80** on the **SNS1 PC Board** (1008).
- (4) Remove the **Transfer Guide (601) Assembly**.

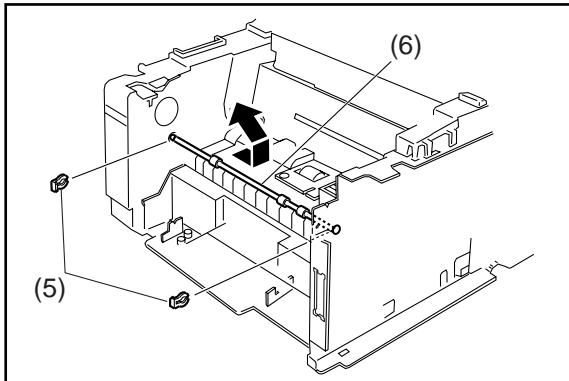

- (5) Remove the 2 **Snap Rings**. (B9).
- (6) Remove the **Feed Roller** (526).

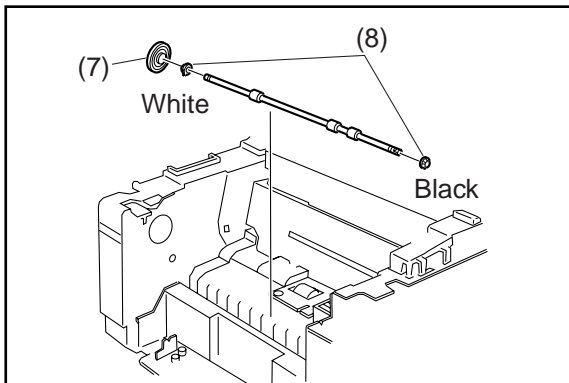

- (7) Remove the **Roller Gear** (529).
- (8) Remove 2 **P6L5 Bushings** (527, 528).

## 2.2.18. Toner Sensor (513), Laser Unit [LSU] (512), SNS3 PC Board (1009)

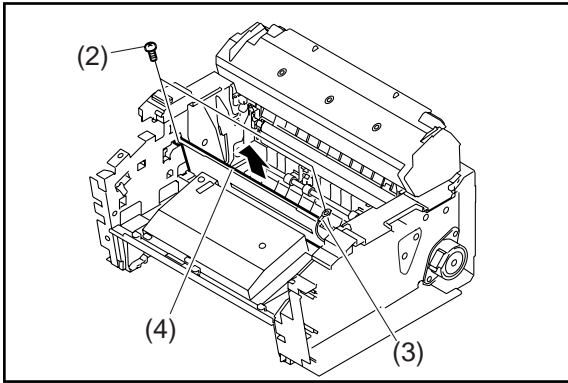

- (1) Remove the **Transmit Guide Assembly** (Refer to 2.2.4.).
- (2) Remove 2 **Screws** (19).
- (3) Remove **Ground Wire** (542).
- (4) Remove the **CCD Shield Plate** (533).

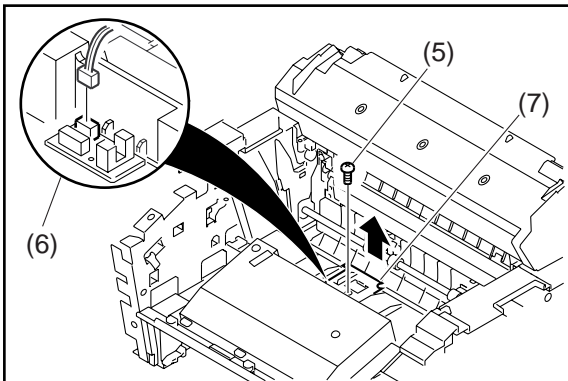

- (5) Remove 1 **Screw** (19).
- (6) Disconnect **Connector CN84** on the **SNS3 PC Board** (1009).
- (7) Remove the **Toner Sensor Spring Plate Assembly**.

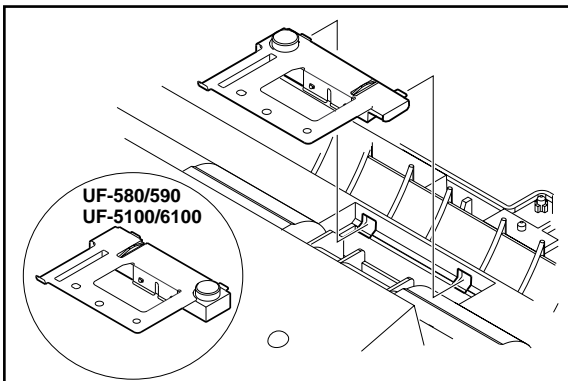

### Note:

When reinstalling, make sure that the Toner Sensor Spring Plate is inserted into the 2 notches in the main frame as illustrated.

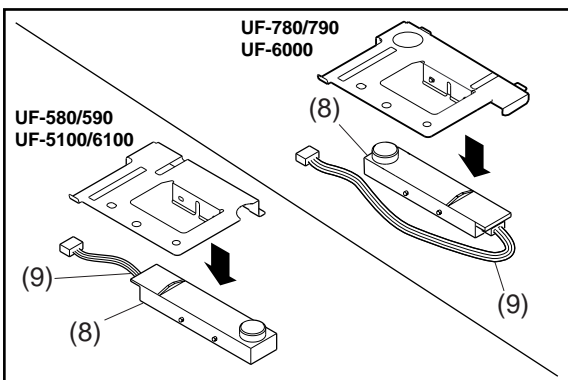

- (8) Remove the **Toner Sensor** (513).
- (9) Disconnect the **Connector** on the Toner Sensor.



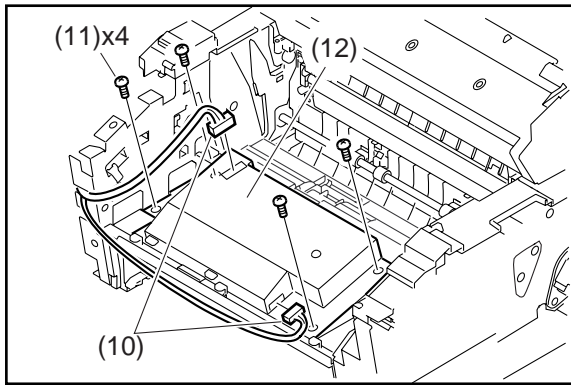

- (10) Disconnect 2 **Connectors** on the **Laser Unit** (512).
- (11) Remove 4 **Screws** (1Y).
- (12) Remove the **Laser Unit** (512).

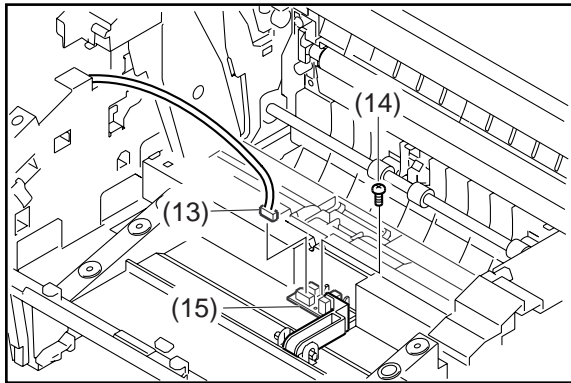

- (13) Disconnect **Connectors CN83** and **CN84** on the **SNS3 PC Board** (1009).
- (14) Remove 1 **Screw** (19).
- (15) Lift up the **No Paper Actuator** (525) and Remove the **SNS3 PC Board** (1009).

## 2.2.19. Bias Transfer Roller (604)

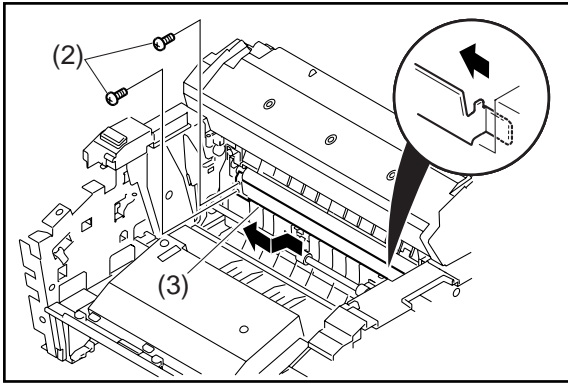

- (1) Remove the **CCD Shield Plate** (Refer to 2.2.18.).
- (2) Remove 2 **Screws** (19).
- (3) Remove the **BTR Guide** (602).

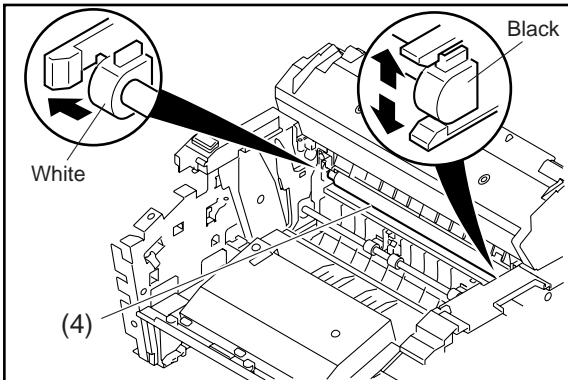

- (4) Release the Latch Hook on the **Transfer Guide** (601) **Assembly** as illustrated and remove the **Bias Transfer Roller** (604).

### Caution:

- Do not touch the surface of the Bias Transfer Roller. Clean the Bias Transfer Roller only with a dry cloth.
- When cleaning or replacing the Bias Transfer Roller, clean both sides of the Transfer Guide with isopropyl alcohol.

## 2.2.20. SNS2 PC Board (1010)

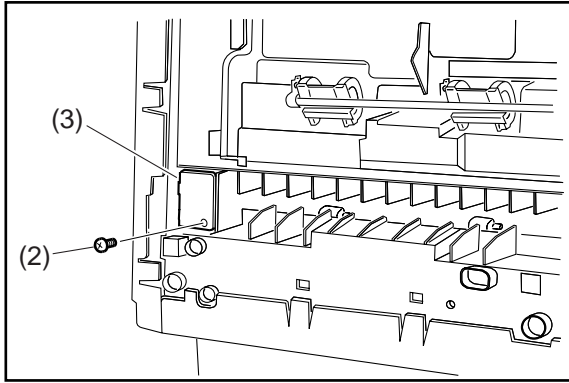

- (1) Place the machine on its rear side.
- (2) Remove 1 **Screw** (19).
- (3) Remove the **Plate A** (507).

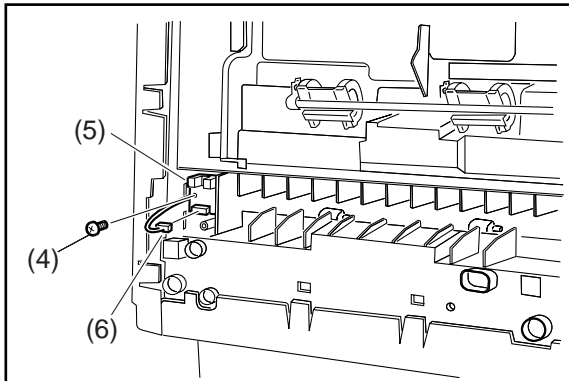

- (4) Remove 1 **Screw** (19).
- (5) Disconnect **Connector CN82** (538) on the **SNS2 PC Board** (1010).
- (6) Remove the **SNS2 PC Board** (1010).

## 2.2.21. Printer Grease Points

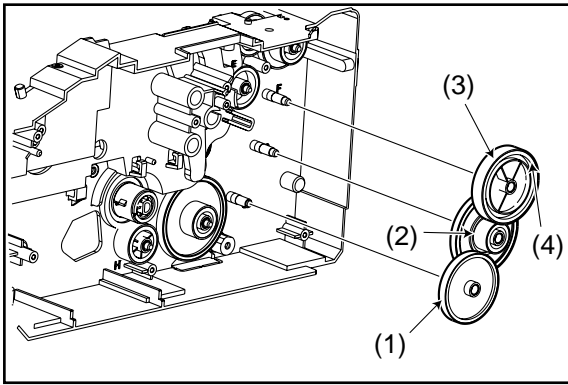













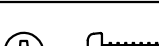
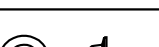

Before reassembling, apply EM-50L Grease to the parts shown in the illustration.

- (1) **B83D22 Gear G (622)** : Gear surface
- (2) **D60D20 Gear B (621)** : Rib surface
- (3) **D55 Gear F (619)** : Gear surface
- (4) **D55 Gear F (619)** : Gear Side surface

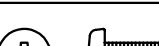
## 2.3. Hardware Identification Template

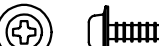
Note: For UF-580/590/780/790 only

Ref No.	Part No.	Figure	Remark
19	XTB3+8JFJ ----- XTB3+8J		Screw ----- Screw (See Note)
23	XYN3+F8FJ ----- XYN3+F8		Screw ----- Screw (See Note)
24	XYN4+F8FJ ----- XYN4+F8		Screw ----- Screw (See Note)
1Q	XYN3+F10FJ ----- XYN3+F10		Screw ----- Screw (See Note)
1Y	XTB3+10JFJ ----- XTB3+10J		Screw ----- Screw (See Note)
4N	XSN3+W8FJ ----- XSN3+W8FC		Screw ----- Screw (See Note)
5Y	XUC4		E-Ring
7B	XTB26+6JFI ----- XTB26+6J		Screw ----- Screw (See Note)
A9	DZPA000100 ----- DZPA000001		Screw ----- Screw (See Note)
B1	DZPB000007		Silver Screw
B4	XTB3+8JFI ----- XTB3+8JK		Screw ----- Screw (See Note)
B5	XSB4+10BN		Screw
B9	DZJM000171		Snap Ring
C2	DZPB000054 ----- DZPB000020		Screw ----- Screw (See Note)
C8	XTW3+8SFJ ----- XTW3+8SFC		Screw ----- Screw (See Note)
G8	XWC3BFJ ----- XWC3B		Star Washer ----- Star Washer (See Note)

## 3 Maintenance, Adjustments and Check Points

### 3.1. Required Tools

No.	Tool	No.	Tool
1	Soft Cloth	6	Tweezer
2	Isopropyl Alcohol	7	Pliers
3	Phillips Screwdriver (#2)	8	Cotton Swab
4	Stubby Phillips Screwdriver (#2)	9	Brush
5	Blade-tip Screwdriver (3/32 in)	10	Molykote EM-50L Grease (Available from Dow Corning, URL: <a href="http://www.dowcorning.com">http://www.dowcorning.com</a> )

### 3.2. Periodic Check Points

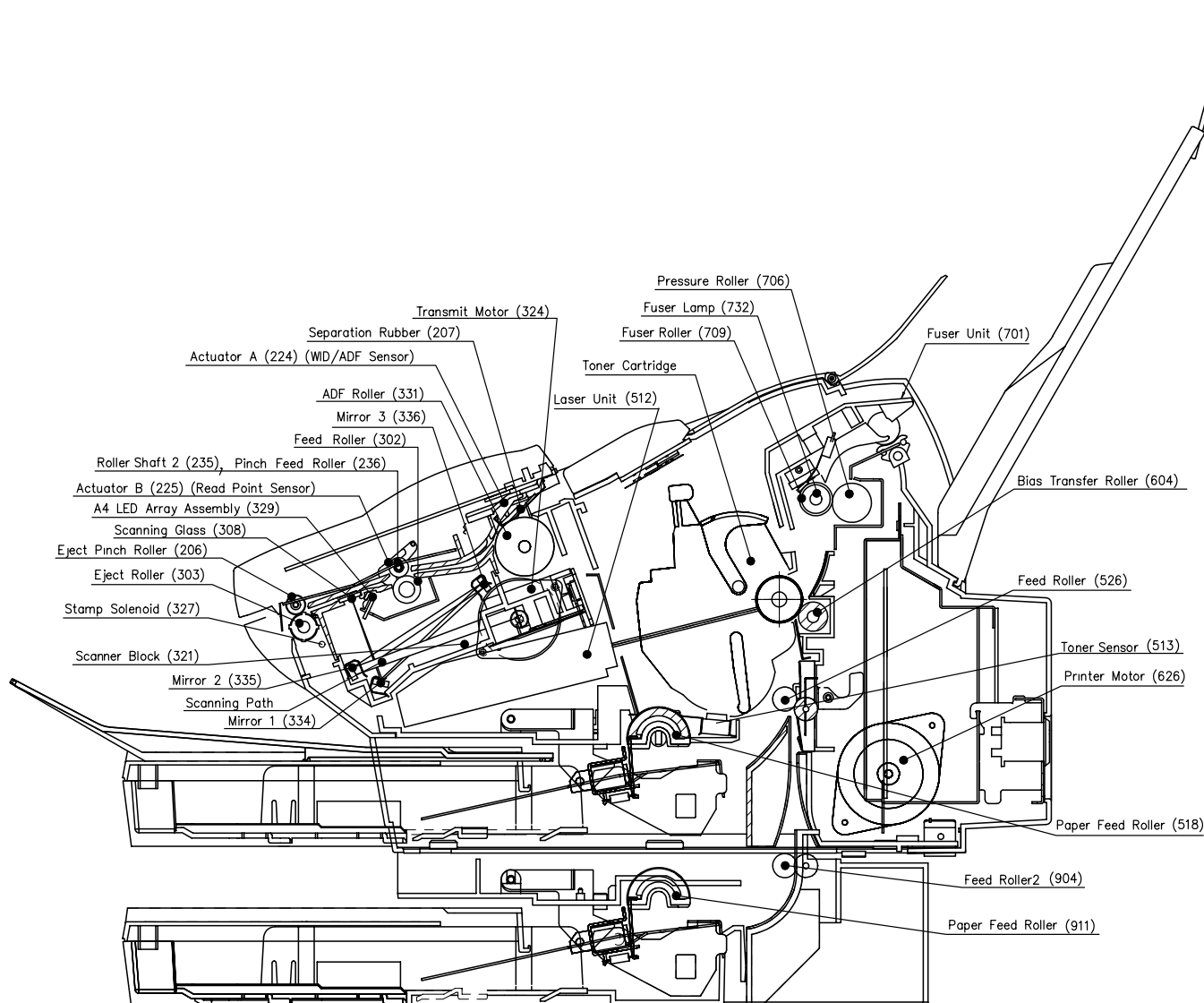

### 3.3. Periodic Maintenance Check List

The chart outlined below is a general guideline for maintenance. The example list is for an average usage of 50 transmitted and received documents per day. Needless to say, the environmental conditions and actual use will vary these factors. The chart below is for reference only.

	Mechanical Parts	Ref. No.	Cleaning		Replacement/Adjustment	
			Cycle	Procedure	Cycle	Procedure
Receiver Unit	Printer Motor	626	-	-	100,000 documents	Refer to sect 2.2.12.
	Toner Cartridge		-	-	approx 7,500 pages (See Note)	-
	Paper Feed Roller	518 911	12 months or 10,000 documents	Refer to sect 2.2.11.	30,000 documents	Refer to sect 2.2.11.
	Feed Roller	526 904	12 months or 10,000 documents	Refer to sect 2.2.17.	-	Refer to sect 2.2.17.
	Bias Transfer Roller	604	12 months or 10,000 documents	Refer to sect 2.2.19.	30,000 documents	Refer to sect 2.2.19.
	Fuser Unit	701	When replacing Print Cartridge	Cleaning sect art	50,000 documents	Refer to sect 2.2.14.
	Fuser Roller	709	When the Recording Paper wraps itself around the roller.	Refer to sect 2.2.15.	(Included as part of the Fuser Unit)	Refer to sect 2.2.15.
	Pressure Roller	706	When the Recording Paper wraps itself around the roller.	Refer to sect 2.2.15.	(Included as part of the Fuser Unit)	Refer to sect 2.2.15.
Transmitter Unit	Roller Shaft 2	235	30,000 documents	Refer to sect 2.2.3.	-	-
	Feed Pinch Roller * Shaft Hole	236	30,000 documents	Refer to sect 2.2.3.	-	-
	ADF Roller	331	12 months or 10,000 documents	Refer to sect 2.2.4.	30,000 documents	Refer to sect 2.2.8.
	Separation Rubber	207	12 months or 10,000 documents	Refer to sect 2.2.2.	30,000 documents	Refer to sect 2.2.2.
	Feed Roller	302	12 months or 10,000 documents	Refer to sect 2.2.4.	30,000 documents	Refer to sect 2.2.9.
	Eject Roller	303	12 months or 10,000 documents	Refer to sect 2.2.4.	30,000 documents	Refer to sect 2.2.6.
	Scanning Glass	308	12 months or 10,000 documents	Refer to sect 2.2.4.	-	-
	Mirrors	334 335 336	12 months or 10,000 documents	Refer to sect 2.2.8.	-	-
	Transmit Motor	324	-	-	100,000 documents	Refer to sect 2.2.7.
	"x" Stamp Head	325	-	-	5,000 documents	Refer to sect 2.2.5.

**Note**

The number of pages is based on the ITU-T Image No. 1 test chart at Multi-Copy mode. Operation environment 68°F (20°C), 50% RH, using A4 paper.

### 3.4. Updating the Firmware

Unlike other machines with removable EPROM (Erasable Programmable ROM), this machine is equipped with a F-ROM (Flash ROM) and an IEEE1284 Parallel Port as standard. The F-ROM offers the flexibility of quick and easy firmware updates. The firmware of the machine can be updated with the removable F-ROM Card or with a PC via the Parallel Port of the unit. (Refer to Section 5.1.9)

The following is the basic procedure to update the firmware of the machine. The details are described in the Firmware Update Tool Operating Instructions.

#### 3.4.1. Creating a Master Firmware Card

##### A.Utilizing the Firmware Update Tool

1. Install the Firmware Update Tool.
2. Install a Flash Memory Card (2MB or higher) into the machine.
3. Follow the instructions included in the Firmware Update Tool Operating Instructions.

##### B.Copy the Firmware from an Existing Machine

1. Unplug the Power Cord to turn the machine OFF.
2. Install a Flash Memory Card (2 MB or higher) into the machine with the Panasonic Logo facing outwards.
3. Plug in the Power Cord to turn the machine ON.
4. Perform the Service Mode 9-2 (Firmware Backup).
5. The firmware is copied into the Flash Memory Card.
6. After the backup is completed, press "STOP" to return to standby.
7. Unplug the Power Cord to turn the machine OFF.
8. Remove the Master Firmware Card that you just created from the machine.
9. Plug in the Power Cord to turn the machine ON.
10. Use this Master Firmware Card to update the firmware on other machines.

**Note:**

1. If a Master Firmware Card is created containing UF-790 Firmware Code (V1.04 Only), **ONLY** a UF-790 machine can be used to delete the Firmware Code on the Flash Card.
2. If a Master Firmware Card containing UF-790 Firmware (V1.04 Only) is installed in a previous model (i.e. DP-130P/135P/135FP/150P/150FX/2000/2500/3000, DX-2000, UF-585/595/885/890/895) when the power to the machine is turned on, the machine will not boot-up at all.

#### 3.4.2 Updating the Firmware using the Master Firmware Card

1. Before starting, print the Fax and Function Parameter Lists.
2. Unplug the Power Cord to turn the machine OFF.
3. Install the appropriate Master Firmware Card into the machine with the Panasonic Logo facing outwards.
4. Plug in the Power Cord to turn the machine ON.
- 5a. Perform the Service Mode 9-1-1 (Firmware Update) (UF-590/790/6000/6100).
- 5b. Perform the Service Mode 9-1 (Firmware Update) (UF-580/780/5100).
6. The firmware is copied into the machine.
7. After the update is completed, the machine reboots itself and returns to standby.
8. Perform the Service Mode 6 (Parameter Initialization).
9. Unplug the Power Cord to turn the machine OFF.
10. Remove the Master Firmware Card from the machine.
11. Plug in the Power Cord to turn the machine ON.
12. Reprogram the Fax and/or Function Parameters according to the lists printed in Step 1 above if the settings are other than factory default.

**Note:**

For a UF-790 with Firmware V1.04 and updating the Firmware to V2.xx, please see Section 3.4.7. for Instructions.



### 3.4.3 Updating the Firmware using a PC via the Parallel Port (Except UF-580/780/5100)

1. Before starting, print the Fax and Function Parameter Lists.
2. Connect the machine to the PC with a Parallel Printer Cable.
3. Install the Panasonic Firmware Programming Wizard software to the PC. (Refer to the Firmware Update Tool Operating Instructions)
4. Perform the Service Mode 9-1-2 (Firmware Update).  
Now the machine is ready to accept programming firmware code from the PC.
5. Start the Panasonic Firmware Program using the Wizard.
6. The firmware is copied into the machine.
7. After the update is completed, the machine reboots itself and returns to standby.

**Note:**

For a UF-790 with Firmware V1.04 and updating the Firmware to V2.xx, please see Section 3.4.7. for Instructions.

### 3.4.4. Erasing the Master Firmware Card (UF-590/790/6000/6100)

1. Unplug the Power Cord to turn the machine OFF.
2. Install the Master Firmware Card into the machine with the Panasonic Logo facing outwards.
3. Plug in the Power Cord to turn the machine ON.
4. Perform the Service Mode 9-5 (PC → Flash Card).
5. The firmware is erased from the card and the following message is shown on the display:

READY TO PROGRAM PRESS SET TO START
--

6. Press "STOP" twice to return to standby.
7. Unplug the Power Cord to turn the machine OFF.
8. Remove the blank Flash Memory Card from the machine.
9. Plug in the Power Cord to turn the machine ON.

### 3.4.5. Erasing the Master Firmware Card (UF-580/780/5100)

1. Unplug the Power Cord to turn the machine OFF.
2. Install the Master Firmware Card into the machine with the Panasonic Logo facing outwards.
3. Plug in the Power Cord to turn the machine ON.
4. Perform the Service Mode 9-5 (Erase Flash Card).
5. After the firmware is erased from the card, the LCD shows service mode default display.
6. Press "STOP" twice to return to standby.
7. Unplug the Power Cord to turn the machine OFF.
8. Remove the blank Flash Memory Card from the machine.
9. Plug in the Power Cord to turn the machine ON.

### 3.4.6. Firmware Version

<UF-780/790>

HOST

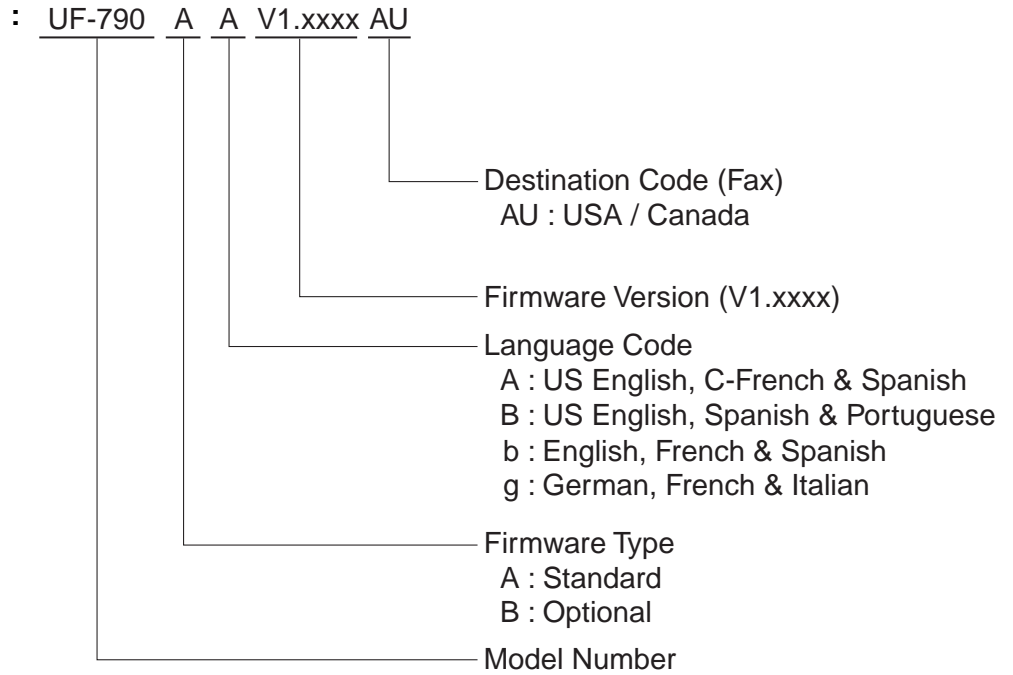

<UF-580/590>

HOST

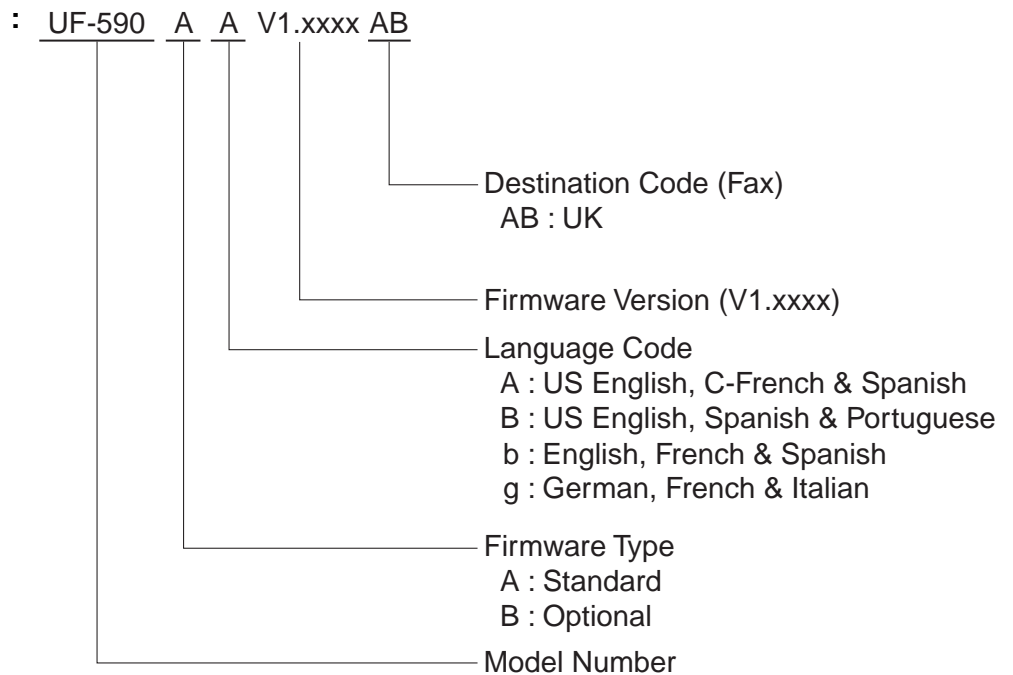

<UF-6000>

HOST

: UF-6000 A A V1.xxxx AU

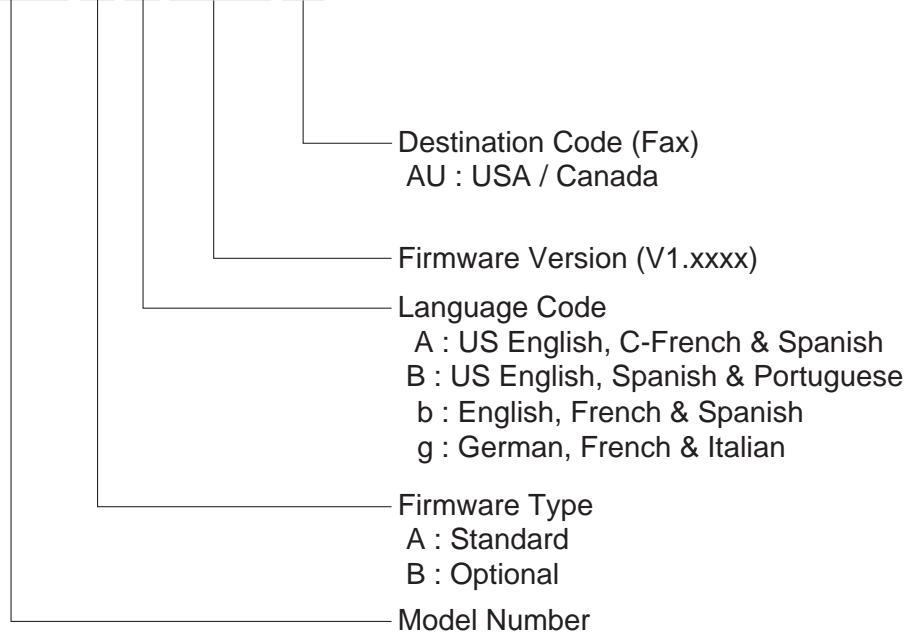

<UF-5100/6100>

HOST

: UF-5100 A A V1.xxxx AB  
UF-6100

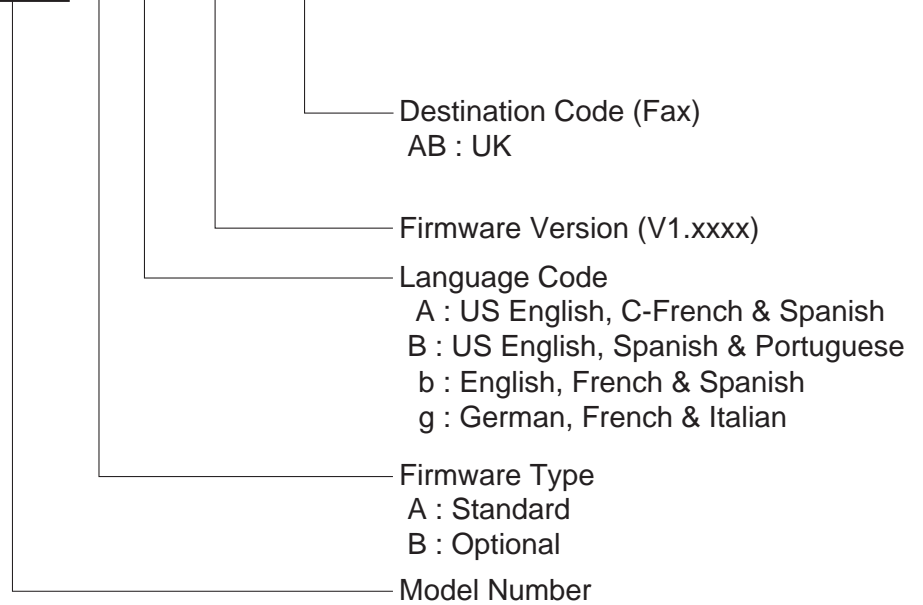

### 3.4.7. Updating the UF-790 Firmware from V1.04 to V2.xx Only

#### ■ PC → Host

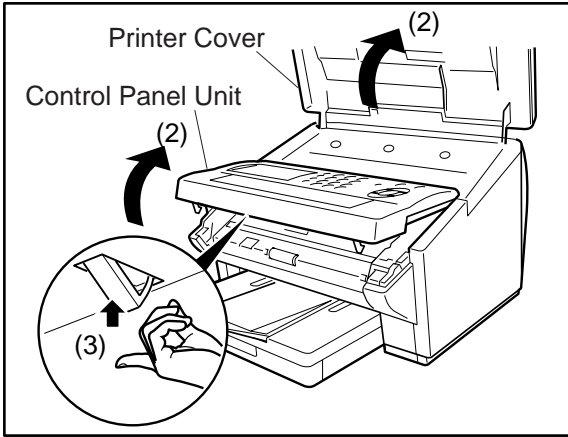

- (1) Unplug the Power Cord.
- (2) Open the Control Panel Unit and the Printer Cover.
- (3) Activate the Read-Point Sensor with your finger as shown and plug in the Power Cord.
- (4) Wait about 10 seconds, then release the Read-Point Sensor and close the Control Panel Unit.
- (5) Start the Firmware Programming Wizard and proceed with downloading the firmware code to the unit.
- (6) Once the firmware code is reprogrammed in the unit, it will reboot automatically and return to standby.
- (7) Perform Parameter Initialization.

#### ■ Card → Host

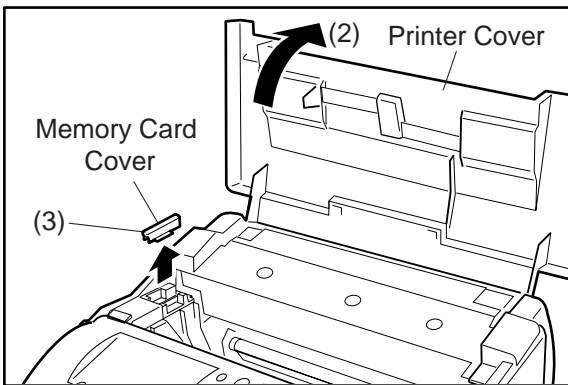

- (1) Unplug the Power Cord.
- (2) Open the Printer Cover.
- (3) Remove the Memory Card Cover.

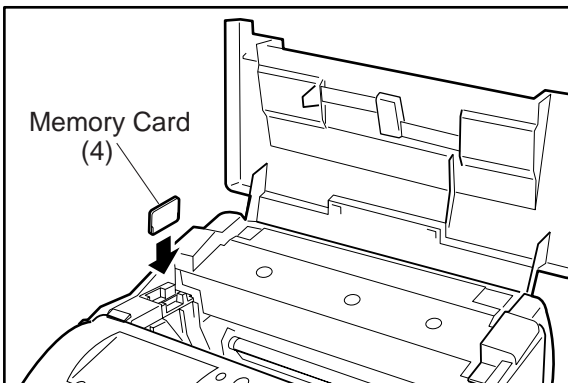

- (4) Insert the Flash Memory Card gently into the card slot with the Panasonic logo facing to the outside of the machine.

**Caution:**

Installing the Flash Memory Card in the wrong direction may damage the connecting pins inside the machine.

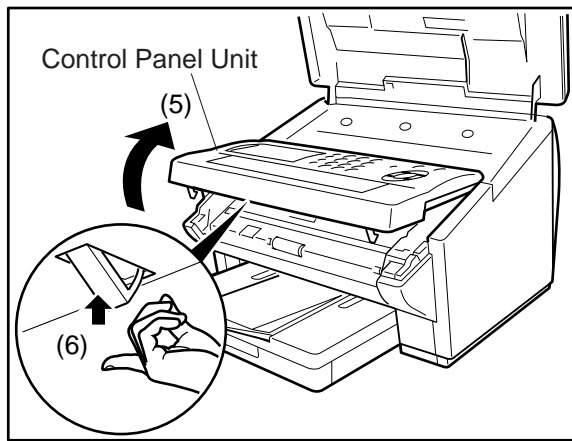

- (5) Open the Control Panel Unit.
- (6) Activate the Read Point Sensor with your finger and plug in the Power Cord.
- (7) Wait approximately 10 seconds, release the Read Point Sensor, close the Control Panel Unit (ADF) and the Printer Cover.
- (8) Allow the unit to complete the Firmware Update (approx. 1-minute). When completed, the unit will reboot and progress to the Standby Mode.
- (9) Unplug the Power Cord.
- (10) Remove the Flash Memory Card.
- (11) Re-install the Memory Card Cover.
- (12) Plug in the Power Cord.
- (13) Perform Parameter Initialization.

### 3.5. Glossary of Electrical Abbreviations

Glossary of Electrical Abbreviations	
Signal Name	Description
+24V	+24 VDC Power Supply
+24VD	+24 VDC Power Supply
+24VM	+24 VDC Power Supply (Motors)
+3.3V	+3.3 VDC Power Supply
+5V	+5 VDC Power Supply
+5VP	+5 VDC Pilot Power Supply (Sleep Mode)
-5V	-5 VDC Power Supply
A1-A22	Address Signal
AGND	Ground
Black (L)	AC Power Supply
BUSY	Peripheral Busy (Peripheral→Host)
Charge	Charge Current: 200 $\mu$ A (AC 300 Hz Sine Wave) & DC Charge Voltage
D0-D15	Data Signal
DATA0-DATA7	Data Signal
DB0-DB7	Data Signal
Development	Development Voltage (AC 1.65 kHz Square Wave) & DC Voltage
DOS	Output Signal
E	Data Read/Write Enable Signal
FCK1	Shift Register Clock
FCK2	Shift Register Clock
FG	Ground
FR	Reset Signal
FSG	Data Transfer Enable Signal
GLLED	GND for LED
GND	Ground
HLIN1	Line Signal for the Fax Handset
HLIN2	Line Signal for the Fax Handset
ID0	Flash Memory Card ID
ID1	Flash Memory Card ID
ID2	Flash Memory Card ID
L+5V	Laser Circuit +5 VDC Power Supply
L1 (R)	Line Signal
L2 (T)	Line Signal
LDRE	Timing Sensor and No Cassette Sensor LED Drive Current
LDSC1	No Cassette Sensor LED Drive Current
LDSP1	No Paper Sensor LED Drive Current
MGND	Ground
MIC (-)	Handset Microphone
MIC (+)	Handset Microphone
MMnA	Motor Drive Signal

<b>Glossary of Electrical Abbreviations</b>	
<b>Signal Name</b>	<b>Description</b>
MMnB	Motor Drive Signal
MMpA	Motor Drive Signal
MMpB	Motor Drive Signal
MTnA	Stepping Signal
MTnB	Stepping Signal
MTpA	Stepping Signal
MTpB	Stepping Signal
nACK	Peripheral Clock / Data Transfer Acknowledge (Peripheral→Host)
nADF1	Paper Feed Roller Solenoid Control Signal
nADF2	Paper Feed Roller Solenoid Control Signal
nAUTOFD	Host Busy (Host→Peripheral)
nBPNT	Read Point Detection Signal
nCCHK1	No Cassette Detection Signal
nCCHK2	No Cassette Detection Signal (2nd Cassette)
nCD	Flash Memory Card Detection Signal
nCE1	+5 VDC Power Supply
nCE2	Low Enable
nCR1	Charge Control DC Output
nCRCK	Charge Control DC Output
nDRCK	Development +AC Clock
nESEN	Paper Exit Signal
nFAULT	Data Available / Error Condition (Peripheral→Host)
nFAULT	Fan Ready Signal
nHSYNC	Horizontal Synchronous Signal
nINIT	Reserve Request / Initialize (Host→Peripheral)
nLDON	Laser Control
nLEDON	LED Enable Signal
nMB4	Flash Memory Size
nMPOFF	Energy Saver Mode Control Signal
nOE	Read Signal - Low Enable
nOP	2nd Feeder Unit Detection Signal
nPCHK1	No Paper Sensor Detection Signal
nPCHK2	No Paper Detection Signal (2nd Cassette)
nPMCK	Tetragon Motor Clock
nPMON	Tetragon Motor Control Signal
nPMRY	Tetragon Motor Ready Signal
nPWSAVE	Energy Saver Mode Transport Signal
nRSEN	Timing Sensor Detection Signal
nSELIN	IEEE1284 Active (Host→Peripheral)
nSSR	Fuser Lamp Control Signal
nSTAMPON	Stamp Control Signal

<b>Glossary of Electrical Abbreviations</b>	
<b>Signal Name</b>	<b>Description</b>
nSTB	Host Clock / Data Transfer Strobe (Host→Peripheral)
nS/H	Sample Hold Signal
nTR0	Transfer Control Cleaning Output
nVIDEO	Laser Control
nWEH	Write H Signal - Low Enable
nWEL	Write L Signal - Low Enable
OS	Output Signal
pADF2	Feed Roller Drive Clutch Control Signal (2nd Cassette)
pBZCLK	Buzzer Signal
pPNLRD	Reception Signal
pPNLRST	Panel Reset Signal
pPNLSD	Transmission Signal
pCMLD	Line Switching Relay Drive Signal
pCTON	Ring Detection Signal
PE	Acknowledge Data Request / Paper Empty Condition (Peripheral→Host)
pHKOF	External Phone Off-Hook Detection Signal
PLH	+5V Pull Up
pSPKOT	Line Signal, Key Tone, Ringer
R/W	Data Read/Write Select Signal
RCV (-)	Handset Receiver
RCV (+)	Handset Receiver
RDY / nBSY	Not Used
RS	Register Select Signal
RSV	Not Used
SELECT	Select Signal (Peripheral→Host)
SNCMN	+2 VDC Power Supply
TGND	Ground
TH1	Thermistor Output Signal
TH2	Thermistor Output Signal
TONER	Remaining Toner Level Signal
Transfer	Transfer Current: (+3 $\mu$ A) & Cleaning Voltage: (-1500 V)
V5	+5 VDC Power Supply
nWAKUP	Energy Saver Mode Enable
White (N)	AC Power Supply



### 3.6. SC PC Board

#### CN1

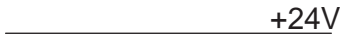
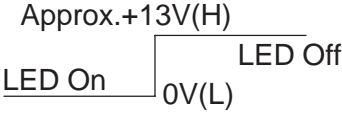
SC PCB Pin No.	Signal Name	Destination	Signal Waveform	Function
CN1-1	+24V	LED Array		+24 VDC Power Supply
CN1-2	nLEDON	LED Array		LED Enable Signal



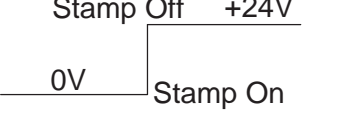



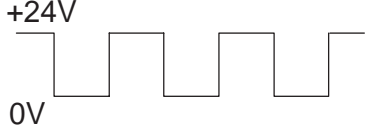
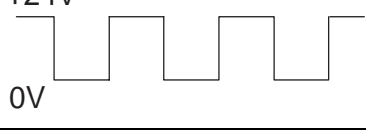
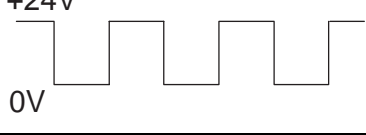
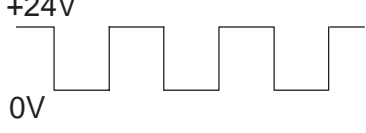

#### CN3

SC PCB Pin No.	Signal Name	Destination	Signal Waveform	Function
CN3-1	+24V	Stamp Solenoid		+24 VDC Power Supply
CN3-2	N.C.			Not Used
CN3-3	nSTAMPON	Stamp Solenoid		Stamp Control Signal

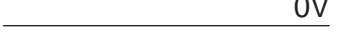
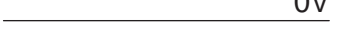
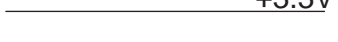

#### CN5

SC PCB Pin No.	Signal Name	Destination	Signal Waveform	Function
CN5-1	MTnB	Transmit Motor		Stepping Signal
CN5-2	MTpB	Transmit Motor		Stepping Signal
CN5-3	MTnA	Transmit Motor		Stepping Signal
CN5-4	MTpA	Transmit Motor		Stepping Signal

**CN6**



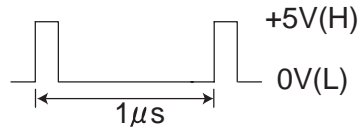
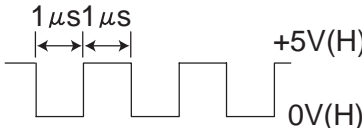
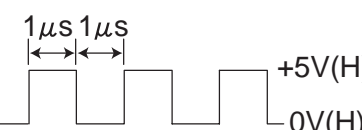
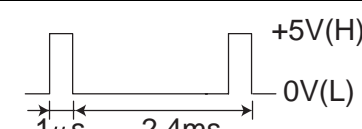

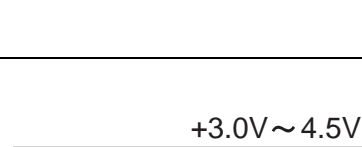
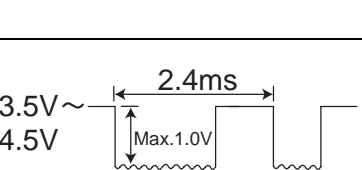
SC PCB Pin No.	Signal Name	Destination	Signal Waveform	Function
CN6-1	+24V	POWER SUPPLY UNIT CN103-1	 +24V	+24 VDC Power Supply
CN6-2	+24V	POWER SUPPLY UNIT CN103-2	 +24V	+24 VDC Power Supply
CN6-3	GND	POWER SUPPLY UNIT CN103-3	 0V	Ground
CN6-4	GND	POWER SUPPLY UNIT CN103-4	 0V	Ground
CN6-5	GND	POWER SUPPLY UNIT CN103-5	 0V	Ground
CN6-6	+3.3V	POWER SUPPLY UNIT CN103-6	 +3.3V	+3.3 VDC Power Supply
CN6-7	+5V	POWER SUPPLY UNIT CN103-7	 +5V	+5 VDC Power Supply
CN6-8	-5V	POWER SUPPLY UNIT CN103-8	 -5V	-5 VDC Power Supply
CN6-9	+5VP	POWER SUPPLY UNIT CN103-9	 +5V	+5 VDC Pilot Power Supply, that provides power to the active components during the Sleep Mode.
CN6-10	nMPOFF	POWER SUPPLY UNIT CN103-10	 +6~7V 0V (Energy Saver Mode)	Energy Saver Mode Control Signal
CN6-11	nSSR	POWER SUPPLY UNIT CN103-11	 Fuser Lamp ON	Fuser Lamp Control Signal

**CN7 (For UF-580/590/780/790)**

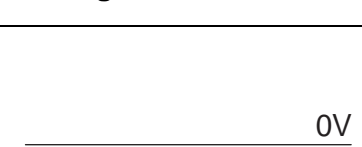
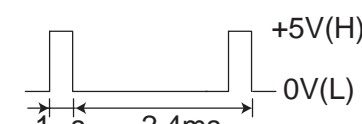

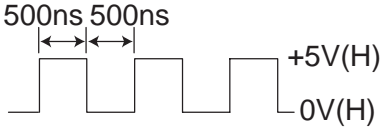
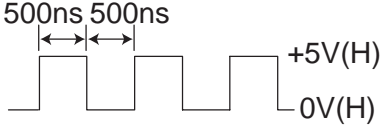
SC PCB Pin No.	Signal Name	Destination	Signal Waveform	Function
CN7-1	FR	CCD PCB CN30-1		Reset Signal
CN7-2	FCK1	CCD PCB CN30-2		Shift Register Clock
CN7-3	FCK2	CCD PCB CN30-3		Shift Register Clock
CN7-4	FSG	CCD PCB CN30-4		Data Transfer Enable Signal
CN7-5	AGND	CCD PCB CN30-5		Ground
CN7-6	+5V	CCD PCB CN30-6		+5 VDC Power Supply
CN7-7	DOS	CCD PCB CN30-7		Output Signal
CN7-8	OS	CCD PCB CN30-8		Output Signal

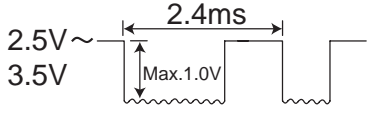
**CN7 (For UF-5100/6000/6100)**

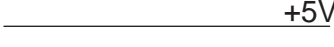
SC PCB Pin No.	Signal Name	Destination	Signal Waveform	Function
CN7-1	AGND	CCD PCB CN30-1		Ground
CN7-2	PHYTG	CCD PCB CN30-2		Data Transfer Enable Signal

SC PCB Pin No.	Signal Name	Destination	Signal Waveform	Function
CN7-3	PHY2	CCD PCB CN30-3		Shift Register Clock
CN7-4	PHY1	CCD PCB CN30-4		Shift Register Clock
CN7-5	AGND	CCD PCB CN30-5		Ground
CN7-6	VOUT	CCD PCB CN30-6		Output Signal
CN7-7	AGND	CCD PCB CN30-7		Ground
CN7-8	+5V	CCD PCB CN30-8		+5 VDC Power Supply

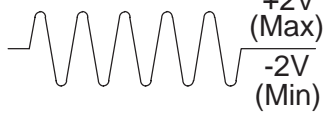
### CN9

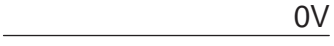
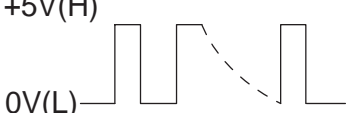

SC PCB Pin No.	Signal Name	Destination	Signal Waveform	Function
CN9-1	pSPKOT	SPEAKER		Line Signal, Key Tone, Ringer
CN9-2	GND	SPEAKER		Ground

### CN12

SC PCB Pin No.	Signal Name	Destination	Signal Waveform	Function
CN12-1	GND	Flash Memory Card		Ground
CN12-2	D3	Flash Memory Card		Data Signal

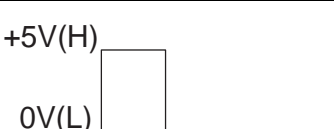

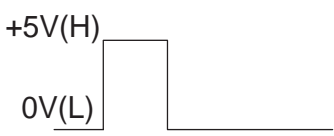
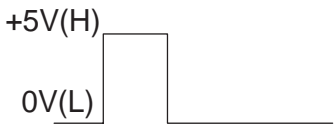
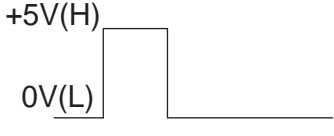
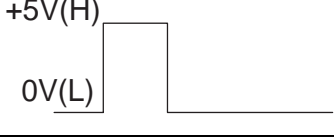
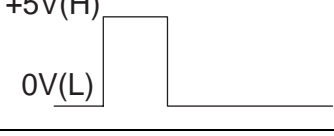
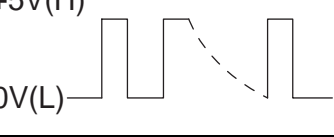
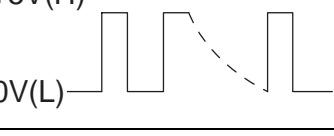
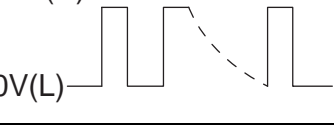
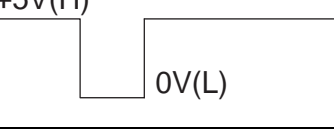
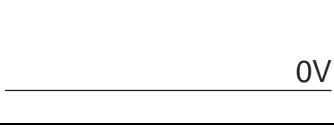
SC PCB Pin No.	Signal Name	Destination	Signal Waveform	Function
CN12-3	D4	Flash Memory Card		Data Signal
CN12-4	D5	Flash Memory Card		Data Signal
CN12-5	D6	Flash Memory Card		Data Signal
CN12-6	D7	Flash Memory Card		Data Signal
CN12-7	nCE1	Flash Memory Card		+5 VDC Power Supply
CN12-8	A11	Flash Memory Card		Address Signal
CN12-9	nOE	Flash Memory Card		Read Signal - Low Enable
CN12-10	A12	Flash Memory Card		Address Signal
CN12-11	A10	Flash Memory Card		Address Signal
CN12-12	A9	Flash Memory Card		Address Signal
CN12-13	A14	Flash Memory Card		Address Signal



SC PCB Pin No.	Signal Name	Destination	Signal Waveform	Function
CN12-14	A15	Flash Memory Card		Address Signal
CN12-15	nWEL	Flash Memory Card		Write L Signal - Low Enable
CN12-16	RDY / nBSY	Flash Memory Card		Not Used
CN12-17	+5V	Flash Memory Card		+5 VDC Power Supply
CN12-18	N.C.	Flash Memory Card		Not Used
CN12-19	A17	Flash Memory Card		Address Signal
CN12-20	A16	Flash Memory Card		Address Signal
CN12-21	A13	Flash Memory Card		Address Signal
CN12-22	A8	Flash Memory Card		Address Signal
CN12-23	A7	Flash Memory Card		Address Signal
CN12-24	A6	Flash Memory Card		Address Signal

SC PCB Pin No.	Signal Name	Destination	Signal Waveform	Function
CN12-25	A5	Flash Memory Card		Address Signal
CN12-26	A4	Flash Memory Card		Address Signal
CN12-27	A3	Flash Memory Card		Address Signal
CN12-28	A2	Flash Memory Card		Address Signal
CN12-29	A1	Flash Memory Card		Address Signal
CN12-30	D0	Flash Memory Card		Data Signal
CN12-31	D1	Flash Memory Card		Data Signal
CN12-32	D2	Flash Memory Card		Data Signal
CN12-33	nWEH	Flash Memory Card		Write H Signal - Low Enable
CN12-34	GND	Flash Memory Card		Ground
CN12-35	GND	Flash Memory Card		Ground

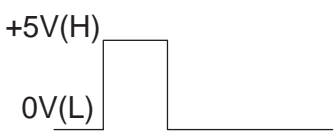
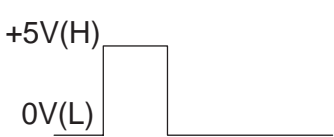
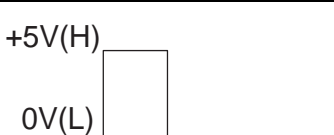
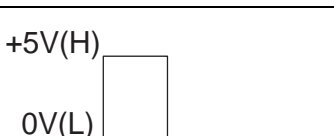
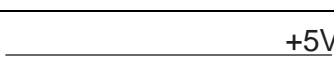

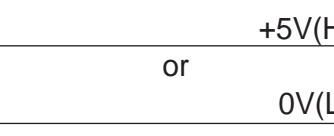

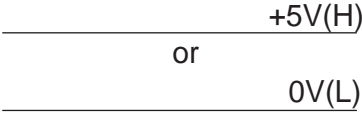
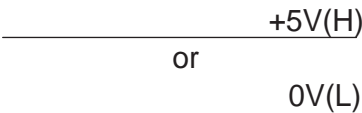
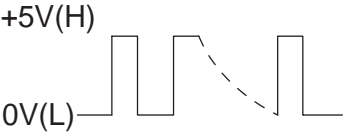
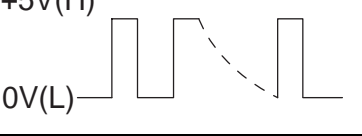
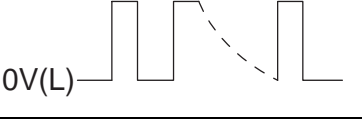
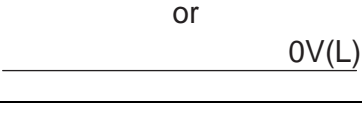





SC PCB Pin No.	Signal Name	Destination	Signal Waveform	Function
CN12-36	nCD	Flash Memory Card		Flash Memory Card Detection Signal H: Card Not Installed L: Card Installed
CN12-37	D11	Flash Memory Card		Data Signal
CN12-38	D12	Flash Memory Card		Data Signal
CN12-39	D13	Flash Memory Card		Data Signal
CN12-40	D14	Flash Memory Card		Data Signal
CN12-41	D15	Flash Memory Card		Data Signal
CN12-42	nCE2	Flash Memory Card		Low Enable
CN12-43	N.C.			Not Used
CN12-44	RSV	Flash Memory Card		Not Used
CN12-45	RSV	Flash Memory Card		Not Used
CN12-46	A18	Flash Memory Card		Address Signal

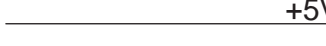

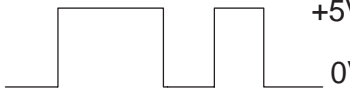

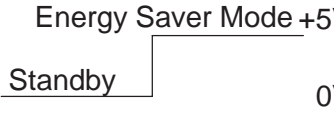
SC PCB Pin No.	Signal Name	Destination	Signal Waveform	Function
CN12-47	A19	Flash Memory Card		Address Signal
CN12-48	A20	Flash Memory Card		Address Signal
CN12-49	A21	Flash Memory Card		Address Signal
CN12-50	A22	Flash Memory Card		Address Signal
CN12-51	+5V	Flash Memory Card		+5 VDC Power Supply
CN12-52	N.C.	Flash Memory Card		Not Used
CN12-53	GND	Flash Memory Card		Ground
CN12-54-56	N.C.	Flash Memory Card		Not Used
CN12-57	RSV	Flash Memory Card		Not Used
CN12-58	N.C.	Flash Memory Card		Not Used
CN12-59	nMB4	Flash Memory Card		Flash Memory Size H: 8MB L: Others
CN12-60	RSV	Flash Memory Card		Not Used

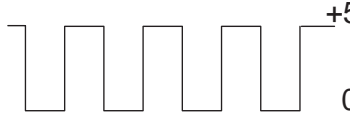
SC PCB Pin No.	Signal Name	Destination	Signal Waveform	Function
CN12-61	N.C.	Flash Memory Card		Not Used
CN12-62	ID2	Flash Memory Card		Flash Memory Card ID
CN12-63	ID1	Flash Memory Card		Flash Memory Card ID
CN12-64	D8	Flash Memory Card		Data Signal
CN12-65	D9	Flash Memory Card		Data Signal
CN12-66	D10	Flash Memory Card		Data Signal
CN12-67	ID0	Flash Memory Card		Flash Memory Card ID
CN12-68	GND	Flash Memory Card		Ground

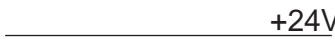
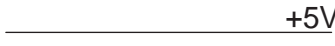
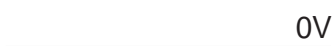
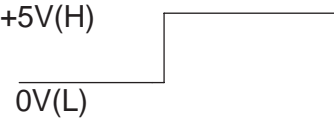

**CN14**

SC PCB Pin No.	Signal Name	Destination	Signal Waveform	Function
CN14-1	GND	PNL PCB CN50-1		Ground
CN14-2	+5V	PNL PCB CN50-2		+5 VDC Power Supply
CN14-3	+5VP	PNL PCB CN50-3		+5 VDC Pilot Power Supply, that provides power to the active components during the Sleep Mode.
CN14-4	GND	PNL PCB CN50-4		Ground
CN14-5	pPNLSD	PNL PCB CN50-5		Transmission Signal
CN14-6	pPNLRD	PNL PCB CN50-6		Reception Signal
CN14-7	nPWSAVE	PNL PCB CN50-7		Energy Saver Mode Transport Signal
CN14-8	nWAKUP	PNL PCB CN50-8		Energy Saver Mode Enable H: Enable L: Disable
CN14-9	pPNLRST	PNL PCB CN50-9		Panel Reset Signal H: Reset L: Not Reset
CN14-10	pBZCLK	PNL PCB CN50-10		Buzzer Signal
CN14-11	nBPNT	PNL PCB CN50-11		Read Point Detection Signal L: Detected

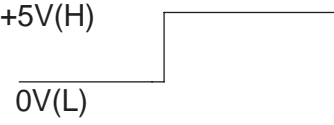
**CN18**

SC PCB Pin No.	Signal Name	Destination	Signal Waveform	Function
CN18-1	L2 (T)	MJR PCB CN28-1		Line Transformer Input Signal
CN18-3	L1 (R)	MJR PCB CN28-3		Ground
CN18-6	+24V	MJR PCB CN29-1		+24 VDC Power Supply
CN18-7	+5VP	MJR PCB CN29-2		+5 VDC Power Supply
CN18-8	GND	MJR PCB CN29-3		Ground
CN18-9	pCMLD	MJR PCB CN29-4		Line Switching Relay Drive Signal H : CML On L : CML Off
CN18-10	pCTON	MJR PCB CN29-5		Ring Detection Signal H : Ring Detected L : Ring Not Detected
CN18-11	pHKOF	MJR PCB CN29-6		External Phone Off-Hook Detection Signal (Phone Line must be connected) H : Off Hook L : On Hook



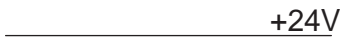
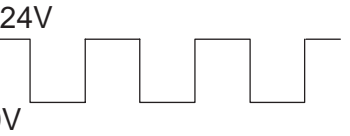
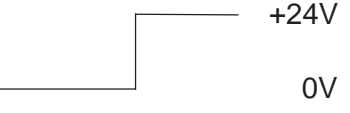
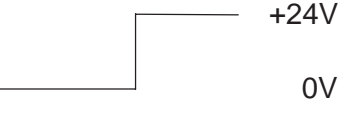
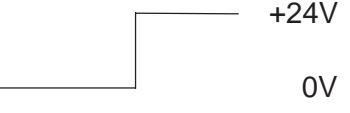

**CN52**

SC PCB Pin No.	Signal Name	Destination	Signal Waveform	Function
CN52-1	TH1	Thermistor Assembly		Thermistor Output Signal
CN52-2	TH2	Thermistor Assembly		Thermistor Output Signal

**CN53**

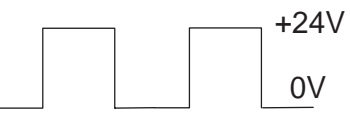

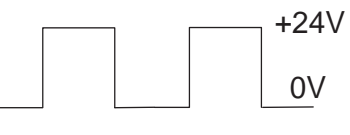
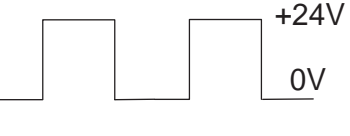
SC PCB Pin No.	Signal Name	Destination	Signal Waveform	Function
CN53-1	+24VM	POWER SUPPLY UNIT CN103-12	 +24V	+24 VDC Power Supply
CN53-2	nDRCK	POWER SUPPLY UNIT CN103-13	 +24V 0V	Development +AC Clock
CN53-3	nCRCK	POWER SUPPLY UNIT CN103-14	 +24V 0V	Charge Control DC Output
CN53-4	nCR1	POWER SUPPLY UNIT CN103-15	 +24V 0V	Charge Control DC Output
CN53-5	nTR0	POWER SUPPLY UNIT CN103-16	 +24V 0V	Transfer Control Cleaning Output

**CN54**

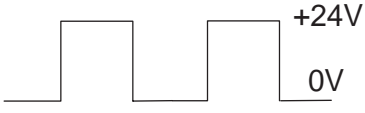
SC PCB Pin No.	Signal Name	Destination	Signal Waveform	Function
CN54-1	MMpA	Main Motor CN118-1	 +24V 0V	Motor Drive Signal
CN54-2	+24VM	Main Motor CN118-2	 +24V	+24 VDC Power Supply
CN54-3	MMnA	Main Motor CN118-3	 +24V 0V	Motor Drive Signal
CN54-4	MMpB	Main Motor CN118-4	 +24V 0V	Motor Drive Signal
CN54-5	+24VM	Main Motor CN118-5	 +24V	+24 VDC Power Supply

SC PCB Pin No.	Signal Name	Destination	Signal Waveform	Function
CN54-6	MMnB	Main Motor CN118-6		Motor Drive Signal



**CN56**

SC PCB Pin No.	Signal Name	Destination	Signal Waveform	Function
CN56-1	+24VM	Paper Feed Solenoid		+24 VDC Power Supply
CN56-2	nADF1	Paper Feed Solenoid		Paper Feed Roller Solenoid Control Signal

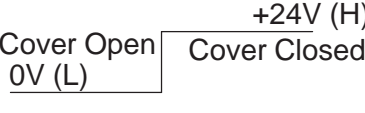
**CN57**

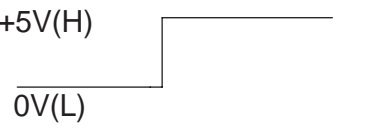

SC PCB Pin No.	Signal Name	Destination	Signal Waveform	Function
CN57-1	+24V	ILS PCB CN73-1		+24 VDC Power Supply
CN57-2	N.C.			
CN57-3	+24VD	ILS PCB CN73-3		Printer Cover Detection Signal

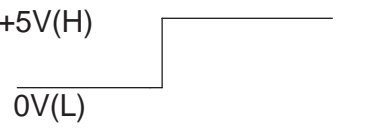
**CN58**

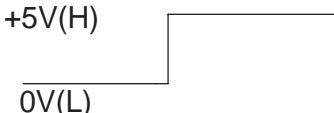

SC PCB Pin No.	Signal Name	Destination	Signal Waveform	Function
CN58-1	nCCHK1	SNS4 PCB CN87-1		No Cassette Detection Signal L: No Cassette
CN58-2	GND	SNS4 PCB CN87-2		Ground
CN58-3	nRSEN	SNS4 PCB CN87-3		Timing Sensor Detection Signal L: Detected

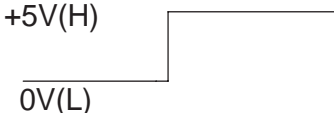
SC PCB Pin No.	Signal Name	Destination	Signal Waveform	Function
CN58-4	N.C.			
CN58-5	+5V	SNS4 PCB CN87-5	 +5V	+5 VDC Power Supply
CN58-6	nESEN	SNS4 PCB CN87-6	 +5V(H) 0V(L)	Paper Exit Sensor Detection Signal L: Detected

### CN59



SC PCB Pin No.	Signal Name	Destination	Signal Waveform	Function
CN59-1	nPCHK1	SNS3 PCB CN83-1	 +5V(H) 0V(L)	No Paper Sensor Detection Signal H: No Paper
CN59-2	LDSP1	SNS3 PCB CN83-2	Approx. +1 VDC	No Paper Sensor LED Drive Current
CN59-3	GND	SNS3 PCB CN83-3	 0V	Ground
CN59-4	TONER	SNS3 PCB CN83-4	Approx. +2 VDC	Remaining Toner Level Signal
CN59-5	+5V	SNS3 PCB CN83-5	 +5V	+5 VDC Power Supply

### CN66 (Except UF-580/780)

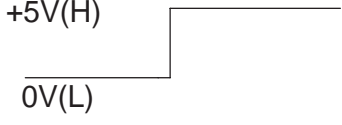
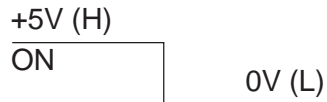
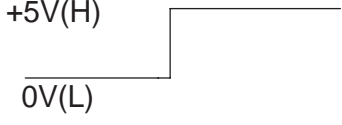
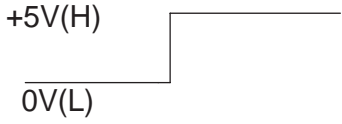
SC PCB Pin No.	Signal Name	Destination	Signal Waveform	Function
CN66-1	+24VM	CST2 PCB CN70-1	 +24V	+24 VDC Power Supply
CN66-2	GND	CST2 PCB CN70-2	 0V	Ground

SC PCB Pin No.	Signal Name	Destination	Signal Waveform	Function
CN66-3	+5V	CST2 PCB CN70-3	 +5V	+5 VDC Power Supply
CN66-4	nPCHK2	CST2 PCB CN70-4	 +5V(H) 0V(L)	No Paper Detection Signal (2nd Cassette) H: No Paper L: Paper
CN66-5	pADF2	CST2 PCB CN70-5	 +5V (H) ON 0V (L)	Feed Roller Drive Clutch Control Signal (2nd Cassette)
CN66-6	nCCHK2	CST2 PCB CN70-6	 +5V(H) 0V(L)	No Cassette Detection Signal (2nd Cassette) L: No Cassette
CN66-7	nOP	CST2 PCB CN70-7	 +5V(H) 0V(L)	2nd Feeder Unit Detection Signal H: No Feeder Unit

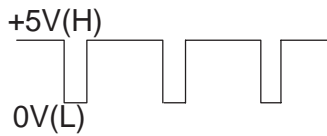
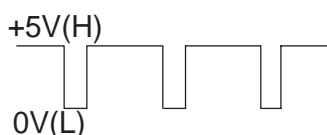

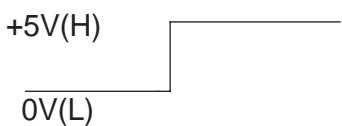
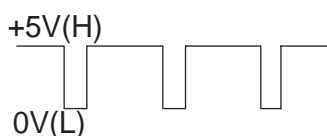
#### CN68

SC PCB Pin No.	Signal Name	Destination	Signal Waveform	Function
CN68-1	nS/H	LSU CN1-1	 +5V(H) 0V(L)	Laser Power Sample/Hold Timing Signal L : Sampling H : Holding
CN68-2	nHSYNC	LSU CN1-2	 +5V(H) 0V(L)	Horizontal Synchronous Signal 2.136 ms (400 dpi) 1.393 ms (600 dpi)
CN68-3	L+5V	LSU CN1-3	 +5V	Laser Circuit +5 VDC Power Supply (Supplied only while the LP is operating)
CN68-4	GND	LSU CN1-4	 0V	Ground
CN68-5	nLDON	LSU CN1-5	 +5V(H) 0V(L)	Laser Control
CN68-6	nVIDEO	LSU CN1-6	 +5V(H) 0V(L)	Video Data L: Black H: White

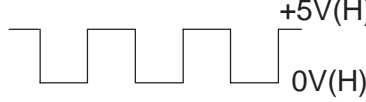
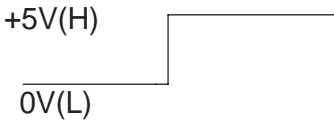
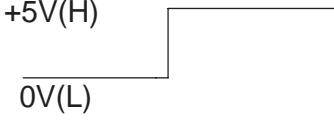

SC PCB Pin No.	Signal Name	Destination	Signal Waveform	Function
CN68-7	GND	LSU CN1-7	 0V	Ground

**CN69**



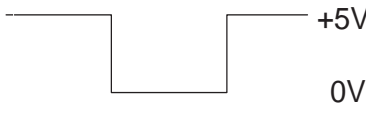
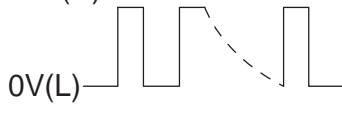
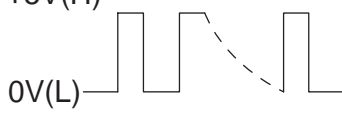
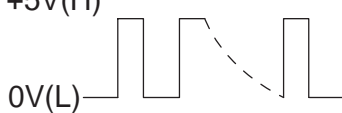

SC PCB Pin No.	Signal Name	Destination	Signal Waveform	Function
CN69-1	nPMCK	LSU CN15-1	 +5V(H) 0V(H)	Tetragon Motor Clock 0.702 kHz (400 dpi) 1.076 kHz (600 dpi)
CN69-2	nPMRY	LSU CN15-2	 +5V(H) 0V(L)	Tetragon Motor Ready Signal H: Not Ready L: Ready
CN69-3	nPMON	LSU CN15-3	 +5V(H) 0V(L)	Tetragon Motor Control Signal H: OFF L: ON
CN69-4	MGND	LSU CN15-4	 0V	Ground
CN69-5	+24VM	LSU CN15-5	 +24V	+24 VDC Power Supply

**CN91 (Except UF-580/780)**

SC PCB Pin No.	Signal Name	Destination	Signal Waveform	Function
CN91-1	nSTB	CENTRONICS I/F	 +5V 0V	Host Clock / Data Transfer Strobe (Host→Peripheral)
CN91-2	DATA0	CENTRONICS I/F	 +5V(H) 0V(L)	Data Signal
CN91-3	DATA1	CENTRONICS I/F	 +5V(H) 0V(L)	Data Signal
CN91-4	DATA2	CENTRONICS I/F	 +5V(H) 0V(L)	Data Signal

SC PCB Pin No.	Signal Name	Destination	Signal Waveform	Function
CN91-5	DATA3	CENTRONICS I/F		Data Signal
CN91-6	DATA4	CENTRONICS I/F		Data Signal
CN91-7	DATA5	CENTRONICS I/F		Data Signal
CN91-8	DATA6	CENTRONICS I/F		Data Signal
CN91-9	DATA7	CENTRONICS I/F		Data Signal
CN91-10	nACK	CENTRONICS I/F		Peripheral Clock / Data Transfer Acknowledge (Peripheral→Host)
CN91-11	BUSY	CENTRONICS I/F		Peripheral Busy (Peripheral→Host)
CN91-12	PE	CENTRONICS I/F		Acknowledge Data Request / Paper Empty Condition (Peripheral→Host)
CN91-13	SELECT	CENTRONICS I/F		Select Signal (Peripheral→Host)
CN91-14	nAUTOFD	CENTRONICS I/F		Host Busy (Host→Peripheral)
CN91-15	Not Used	CENTRONICS I/F		Not Used

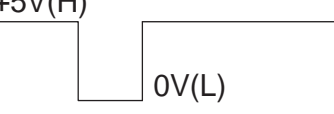
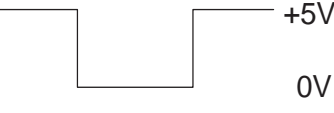
SC PCB Pin No.	Signal Name	Destination	Signal Waveform	Function
CN91-16	GND	CENTRONICS I/F	_____ 0V	Ground
CN91-17	FG	CENTRONICS I/F	_____ 0V	Ground
CN91-18	PLH	CENTRONICS I/F	_____ +5V	+5V Pull Up
CN91-19	GND	CENTRONICS I/F	_____ 0V	Ground
CN91-20	GND	CENTRONICS I/F	_____ 0V	Ground
CN91-21	GND	CENTRONICS I/F	_____ 0V	Ground
CN91-22	GND	CENTRONICS I/F	_____ 0V	Ground
CN91-23	GND	CENTRONICS I/F	_____ 0V	Ground
CN91-24	GND	CENTRONICS I/F	_____ 0V	Ground
CN91-25	GND	CENTRONICS I/F	_____ 0V	Ground
CN91-26	GND	CENTRONICS I/F	_____ 0V	Ground
CN91-27	GND	CENTRONICS I/F	_____ 0V	Ground

SC PCB Pin No.	Signal Name	Destination	Signal Waveform	Function
CN91-28	GND	CENTRONICS I/F		Ground
CN91-29	GND	CENTRONICS I/F		Ground
CN91-30	GND	CENTRONICS I/F		Ground
CN91-31	nINIT	CENTRONICS I/F		Reverse Request / Initialize (Host→Peripheral)
CN91-32	nFAULT	CENTRONICS I/F		Data Available / Error Condition (Peripheral→Host)
CN91-33	Not Used	CENTRONICS I/F		Not Used
CN91-34	Not Used	CENTRONICS I/F		Not Used
CN91-35	Not Used	CENTRONICS I/F		Not Used
CN91-36	nSELIN	CENTRONICS I/F		IEEE1284 Active (Host→Peripheral)

### 3.7. MJR PC Board

#### CN20

MJR PCB Pin No.	Signal Name	Destination	Signal Waveform	Function
CN20-3	LT2(T)	Telephone Line		Line Signal
CN20-4	LT1(R)	Telephone Line		Line Signal

#### CN23

MJR PCB Pin No.	Signal Name	Destination	Signal Waveform	Function
CN23-1	N.C.			Not Used
CN23-2	N.C.			Not Used
CN23-3	HLIN1	SRU PCB CN90-1		Line Signal for the Fax Handset
CN23-4	HLIN2	SRU PCB CN90-2		Line Signal for the Fax Handset
CN23-5	N.C.			Not Used

#### CN28 and CN29

Refer to SC PC Board CN18.

### 3.8. Power Supply Unit

#### CN101

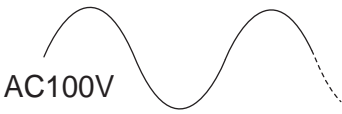
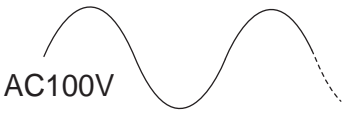
PS Unit Pin No.	Signal Name	Destination	Signal Waveform	Function
CN101-1	Black (L)	ACI PC Board	 AC100V	AC Power Supply
CN101-2	N.C.			Not Used
CN101-3	White (N)	ACI PC Board	 AC100V	AC Power Supply

#### CN102

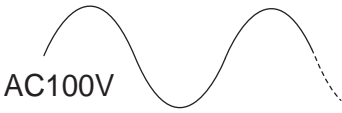
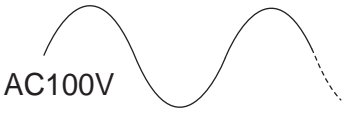
PS Unit Pin No.	Signal Name	Destination	Signal Waveform	Function
CN102-1	Black (L)	Fuser Lamp	 AC100V	AC Power Supply
CN102-2	N.C.			Not Used
CN102-3	White (N)	Thermostat Thermal Fuse	 AC100V	AC Power Supply

#### CN103

Refer to SC PC Board CN6 and CN53.

**CN201**

PS Unit Pin No.	Signal Name	Destination	Signal Waveform	Function
CN201-1	Development	Development Roller		Development Voltage (AC 1.65 kHz Square Wave) & DC Voltage
CN201-2	N.C.			Not Used
CN201-3	N.C.			Not Used
CN201-4	N.C.			Not Used
CN201-5	Charge	Bias Charge Roller		Charge Current: 200 $\mu$ A (AC 300 Hz Sine Wave) & DC Charge Voltage

**CN202**





PS Unit Pin No.	Signal Name	Destination	Signal Waveform	Function
CN202	Transfer	Bias Transfer Roller		(1) Transfer Current: (+3 $\mu$ A) (2) Cleaning Voltage: (-1500 V)

### 3.9. PNL PC Board

#### CN50

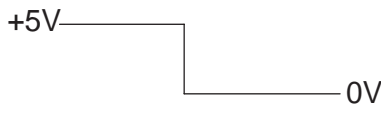
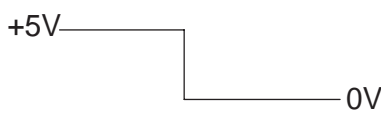
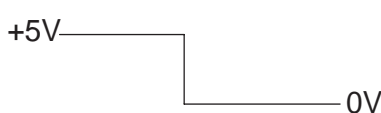
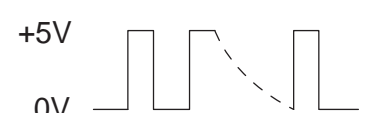
Refer to SC PC Board CN14.

#### LCD

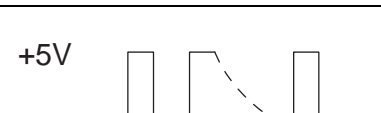
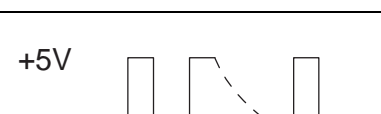
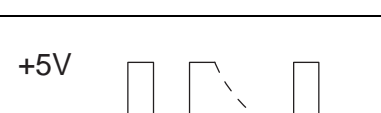
PNL PCB Pin No.	Signal Name	Destination	Signal Waveform	Function
LCD-1	RS	LCD Module-1		Register Select Signal H: Data Register L: Instruction Register
LCD-2	R/W	LCD Module-2		Data Read/Write Select Signal H: Read L: Write
LCD-3	E	LCD Module-3		Data Read/Write Enable Signal H: Enable L: Disable
LCD-4	DB0	LCD Module-4		Data Signal
LCD-5	DB1	LCD Module-5		Data Signal
LCD-6	DB2	LCD Module-6		Data Signal
LCD-7	DB3	LCD Module-7		Data Signal
LCD-8	DB4	LCD Module-8		Data Signal
LCD-9	DB5	LCD Module-9		Data Signal
LCD-10	DB6	LCD Module-10		Data Signal





PNL PCB Pin No.	Signal Name	Destination	Signal Waveform	Function
LCD-11	DB7	LCD Module-11		Data Signal
LCD-12	GND	LCD Module-12		Ground
LCD-13	+5V	LCD Module-13		+5 VDC Power Supply
LCD-14	+5V	LCD Module-14		+5 VDC Power Supply
LCD-15	V5	LCD Module-15		Power Supply for LCD
LCD-16	GND	LCD Module-16		Ground

### 3.10. SNS3 PC Board

#### CN83

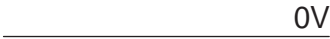

Refer to SC PC Board CN59.

#### CN84

SNS3 PCB Pin No.	Signal Name	Destination	Signal Waveform	Function
CN84-1	GND	Toner Sensor	 0V	Ground
CN84-2	TONER	Toner Sensor	Approx. +2 VDC	Remaining Toner Level Signal
CN84-3	+5V	Toner Sensor	 +5V	+5 VDC Power Supply

### 3.11. SNS4 PC Board

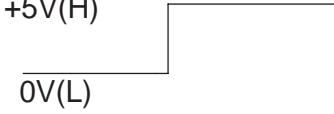
#### CN85

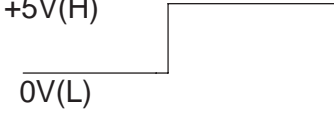
SNS3 PCB Pin No.	Signal Name	Destination	Signal Waveform	Function
CN85-1	nCCHK1	SNS1 PCB CN81-1		No Cassette Detection Signal L: No Cassette
CN85-2	GND	SNS1 PCB CN81-2		Ground
CN85-3	nRSEN	SNS1 PCB CN81-3		Timing Sensor Detection Signal L: Detected
CN85-4	LDRE	SNS1 PCB CN81-4	Approx. +2 VDC	Timing Sensor and No Cassette Sensor LED Drive Current

#### CN87

Refer to SC PC Board CN58.

### 3.12. SNS1 PC Board

#### CN80

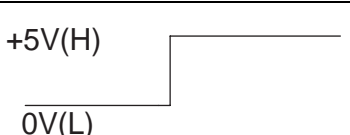
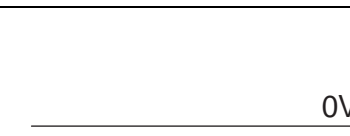
SNS1 PCB Pin No.	Signal Name	Destination	Signal Waveform	Function
CN80-1	nCCHK1	SNS2 PCB CN82-1		No Cassette Detection Signal L: No Cassette
CN80-2	GND	SNS2 PCB CN82-2		Ground
CN80-3	LDSC1	SNS2 PCB CN82-3	Approx. +1 VDC	No Cassette Sensor LED Drive Current

#### CN81

Refer to SNS4 PC Board CN85.

### 3.13. SNS2 PC Board

#### CN82

Refer to SNS1 PC Board CN80.

### 3.14. CCD PC Board

#### CN30

Refer to SC PC Board CN7.

### 3.15. ILS PC Board

#### CN73

Refer to SC PC Board CN57.

### 3.16. ACI PC Board



Refer to Power Supply Unit CN101.

### 3.17. CST2 PC Board (Optional)



#### CN70

Refer to SC PC Board CN66.

#### CN71

CST2 PCB Pin No.	Signal Name	Destination	Signal Waveform	Function
CN71-1	+24VM	Paper Feed Solenoid		+24 VDC Power Supply
CN70-2	nADF2	Paper Feed Solenoid		Paper Feed Roller Solenoid Control Signal

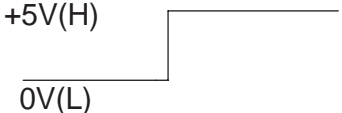
#### CN74

CST2 PCB Pin No.	Signal Name	Destination	Signal Waveform	Function
CN74-1	nCCHK2	SNS2 PCB (Optional) CN82-1		No Cassette Detection Signal (2nd Cassette) L: No Cassette
CN74-2	GND	SNS2 PCB (Optional) CN82-2		Ground
CN74-3	SNCMN	SNS2 PCB (Optional) CN82-3		+2 VDC Power Supply

### 3.18. SNS2 PC Board (Optional)

#### CN82

Refer to CST2 PC Board CN74.

### 3.19. SRU PC Board (Optional)

#### CN90

Refer to MJR PC Board CN23.

#### CN91

SRU PCB Pin No.	Signal Name	Destination	Signal Waveform	Function
CN91-1	N.C.			Not Used
CN91-2	MIC (+)	Telephone Handset CN		Handset Microphone
CN91-3	RCV (+)	Telephone Handset CN		Handset Receiver
CN91-4	RCV (-)	Telephone Handset CN		Handset Receiver
CN91-5	MIC (-)	Telephone Handset CN		Handset Microphone
CN91-6	TGND			Ground

# 4 Troubleshooting

## 4.1. Initial Troubleshooting Flowchart

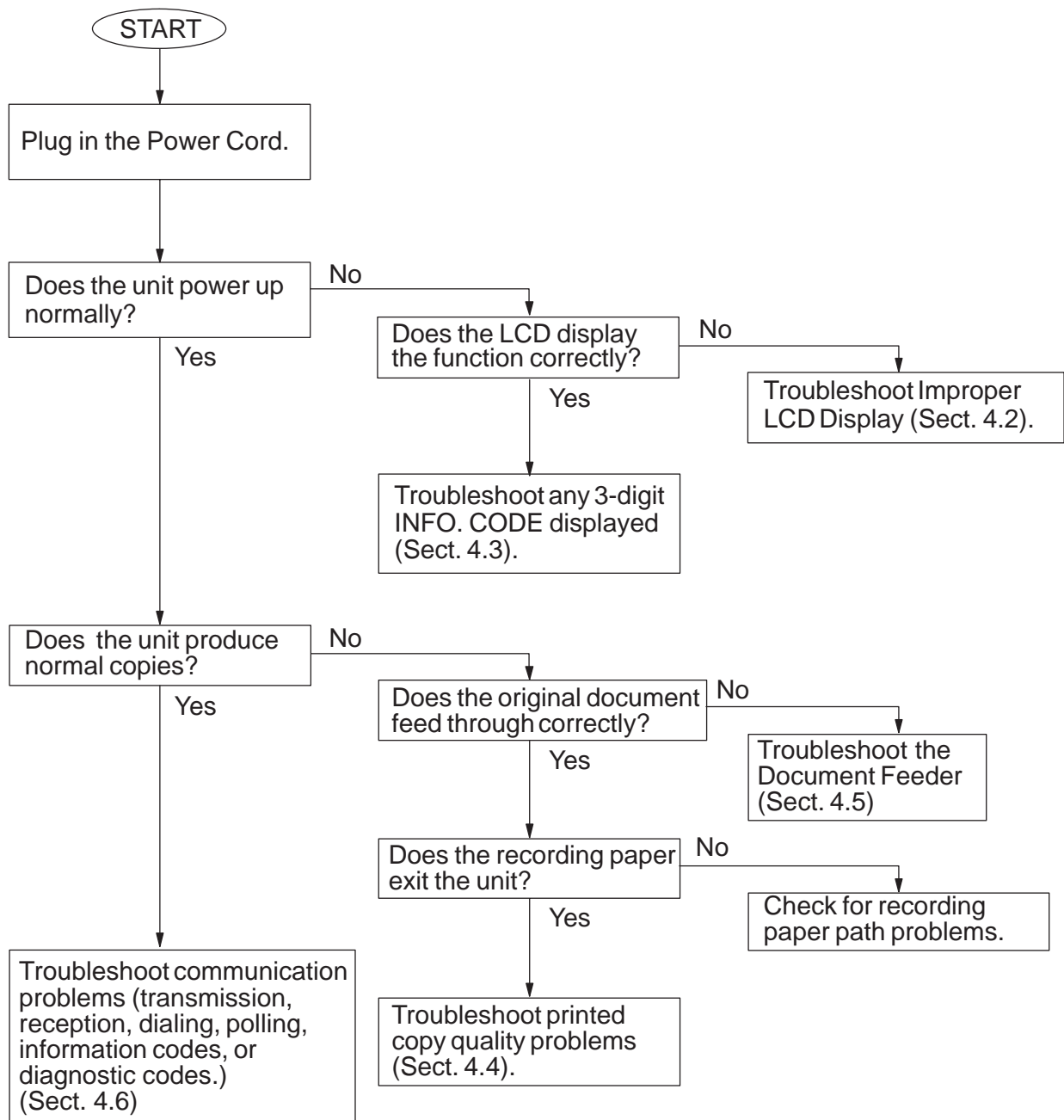

## 4.2. Improper LCD Display

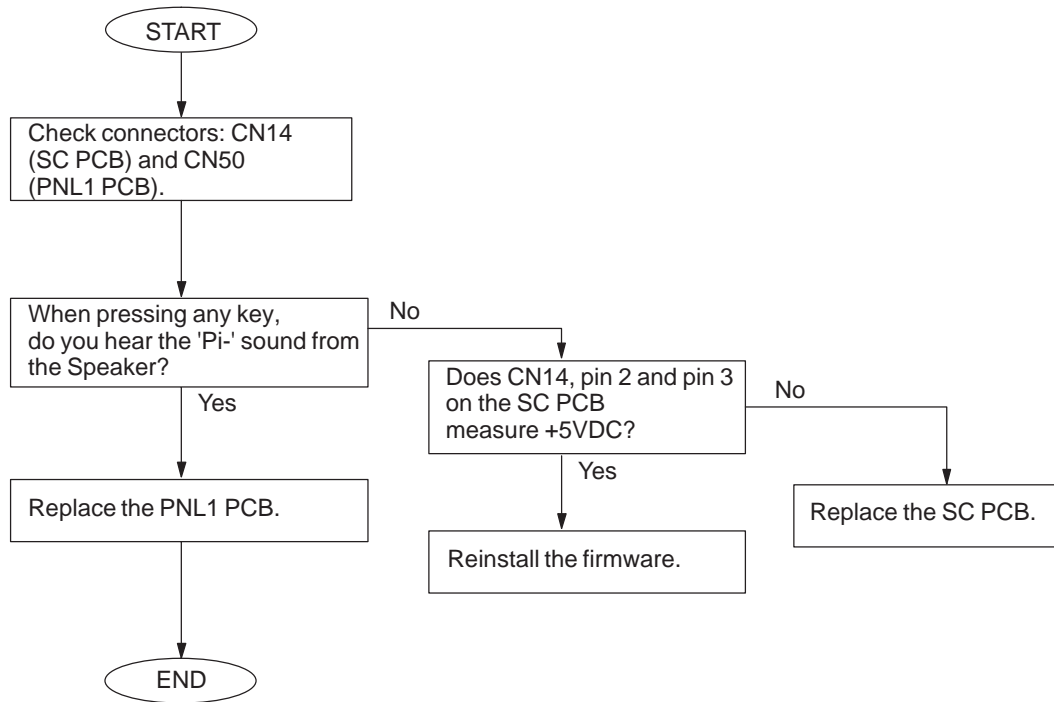



### 4.3. Information Codes (INFO. CODES)

The 3-digit information codes display to show the unit's status. These codes also print on the journal. The following table indicates appropriate sections for troubleshooting.

Code	Explanation	Phase	Section
001, 002, 007	Recording paper jam	C, D	4.3.8.
010	No recording paper	B, C	4.3.9.
030	Document misfeeding	B	4.3.10.
031	Document too long	C	4.3.10.
400	Transmission error	B	4.3.1.
401	Transmission error	B	4.3.2.
402	Transmission error	B	4.3.2.
403	Polling reception error	B	4.3.12.
404	Transmission error	B	4.3.3.
405	Transmission error	B	4.3.3.
407	Transmission error	D	4.3.3.
408	Transmission error	D	4.3.5.
409	Transmission error	D	4.3.5.
411	Polling reception error	B	4.3.12.
414	Polling reception error	B	4.3.12.
415	Remote side mis-operation	B	4.3.12.
416	Reception error	D	4.3.4.
417	Reception error	C	4.3.5.
418	Reception error	C	4.3.5.
420	Reception error	B	4.3.1.
422	Transmission error	B	4.3.2.
434	Signal noise level too high	B	4.3.6.
459	Reception error	C	4.3.7.
490	Reception error	C	4.3.5.
494	Reception error	C	4.3.7.
495	Reception error	C	4.3.7.
630	Remote unit Busy	B	4.3.11.
634	No busy tone detected	B	--
800 - 962	Advanced Communication error	--	--

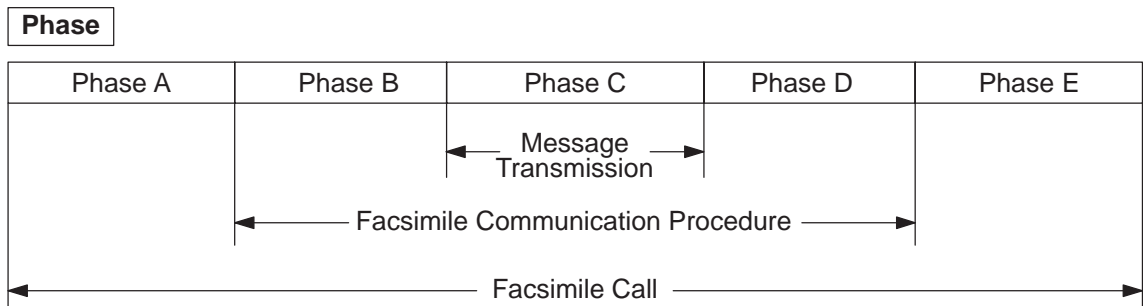

- Phase A : Call establishment
- Phase B : Pre-message procedure
- Phase C : Message transmission
- Phase D : Post-message procedure
- Phase E : Call release

### 4.3.1. Information Codes: 400, 420

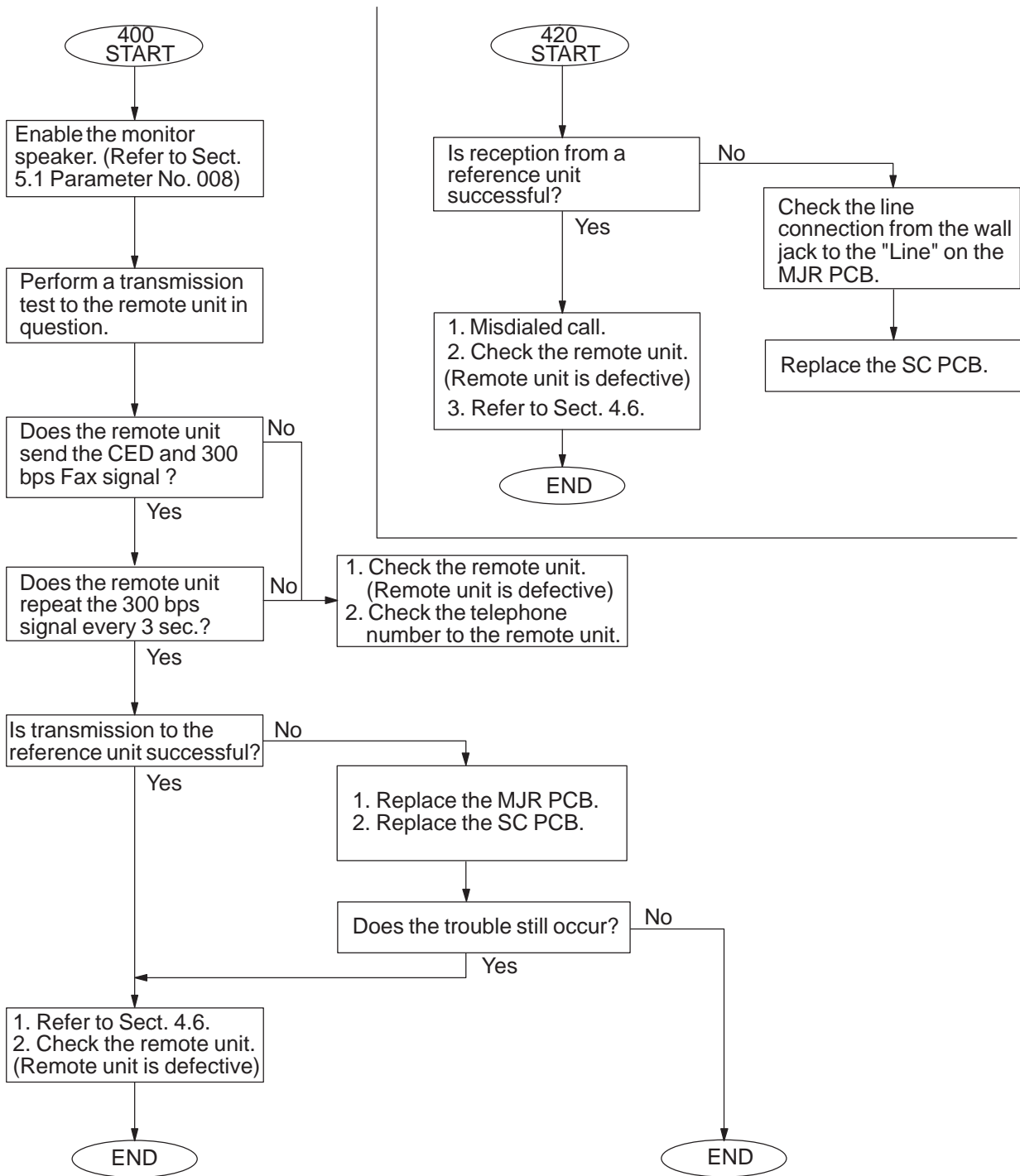

### 4.3.2. Information Codes: 401, 402, 422

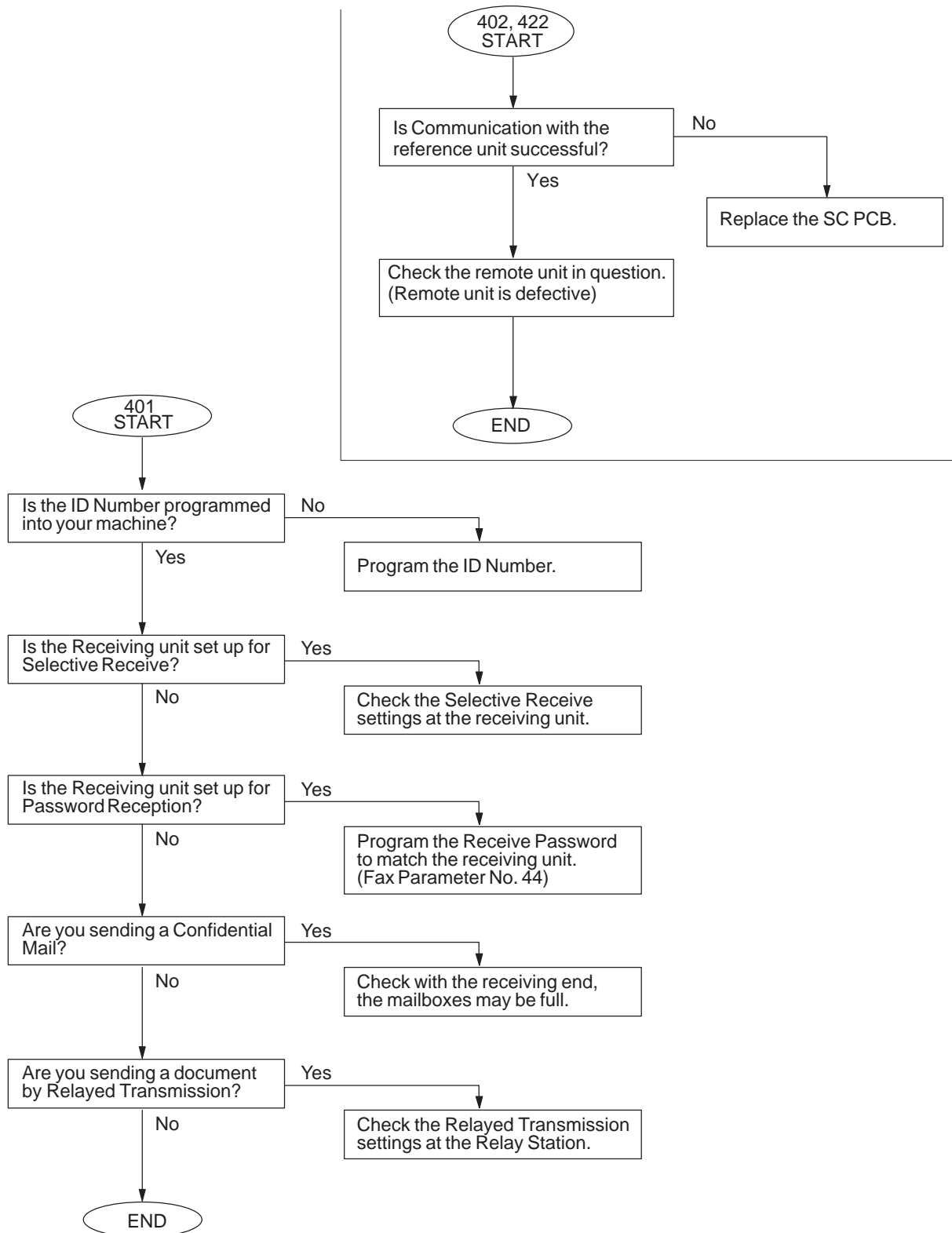

### 4.3.3. Information Codes: 404, 405, 407

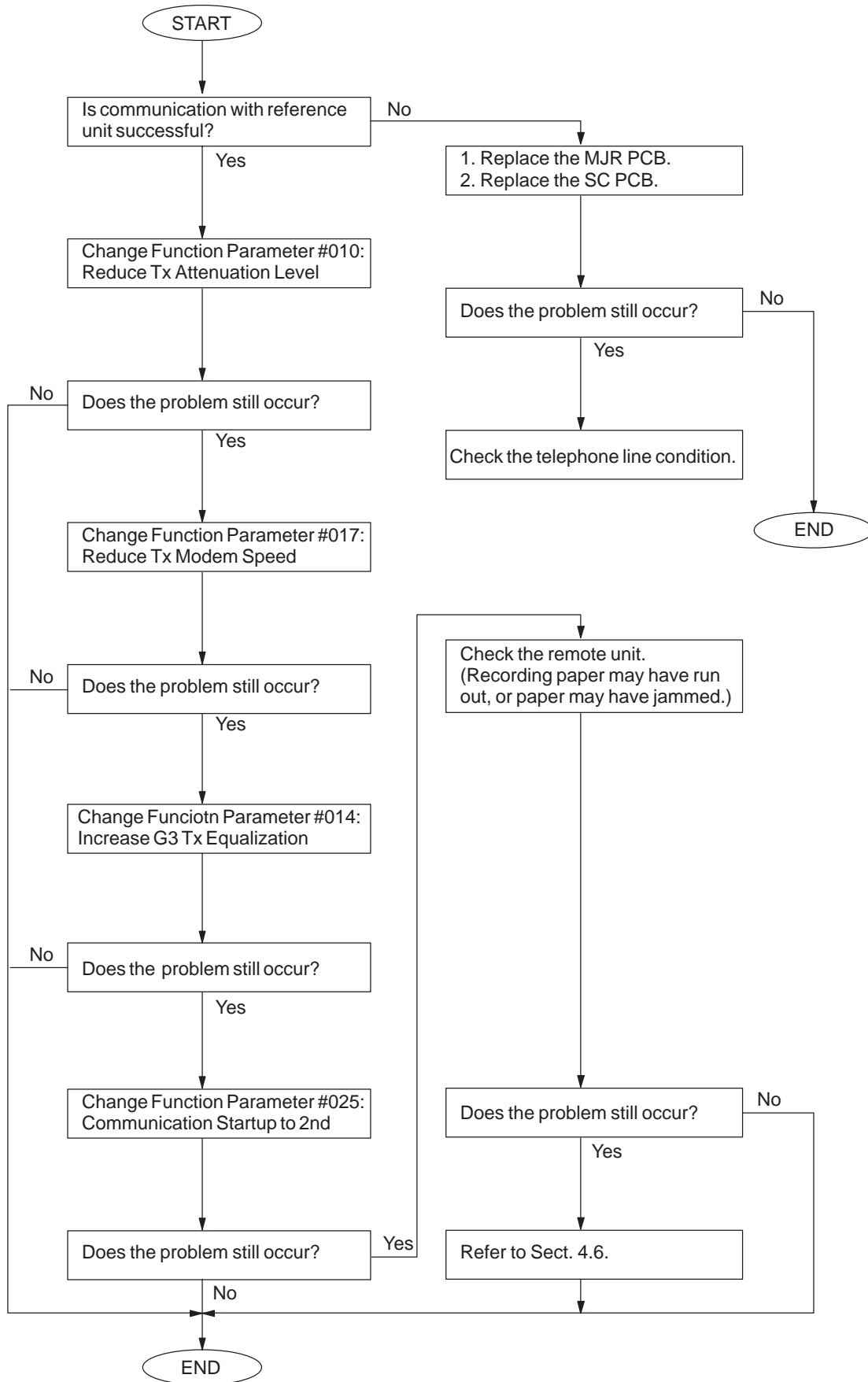

#### 4.3.4. Information Code: 416

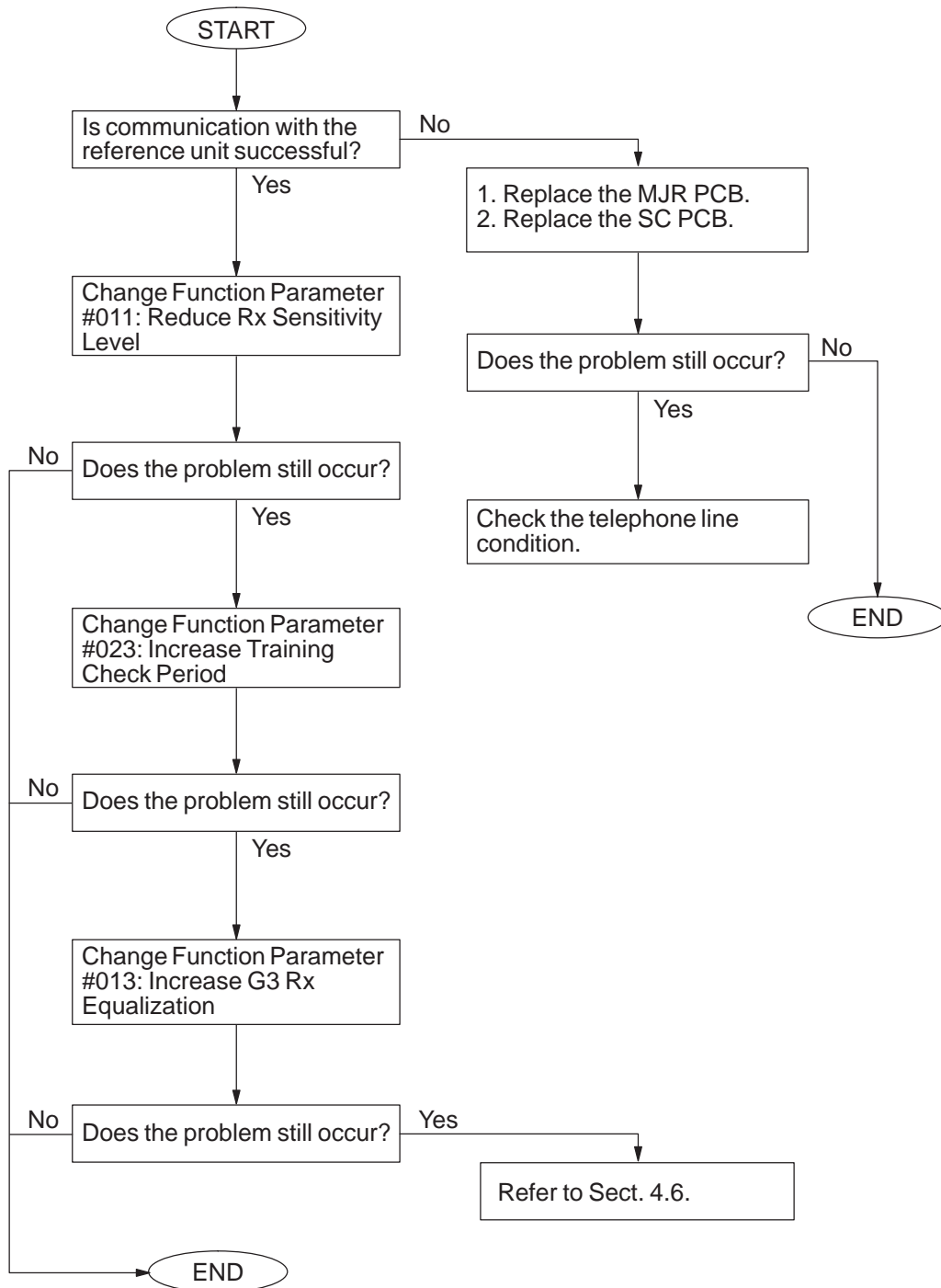

4.3.5. Information Codes: 408, 409, 417, 418, 490

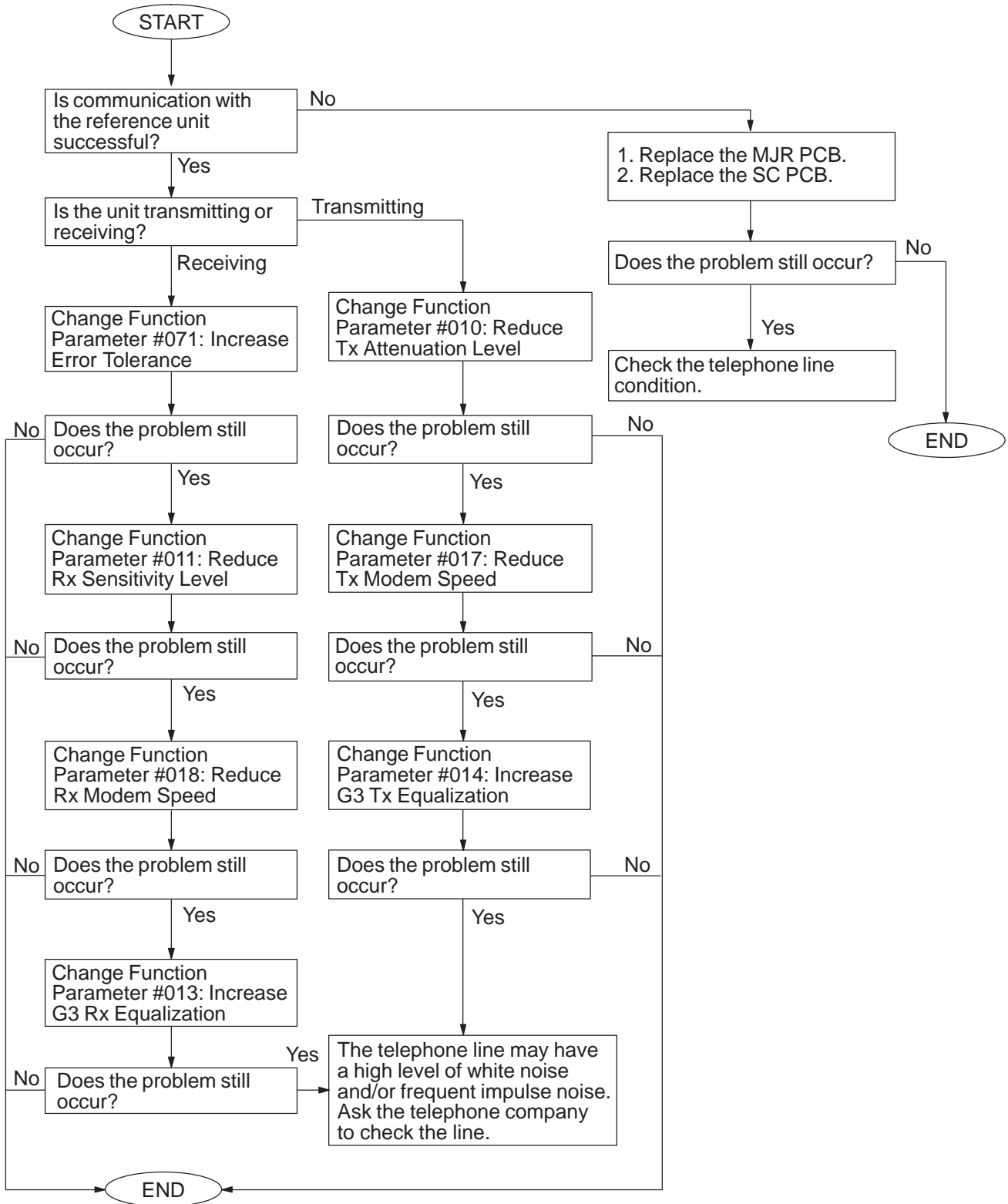

#### 4.3.6. Information Code: 434

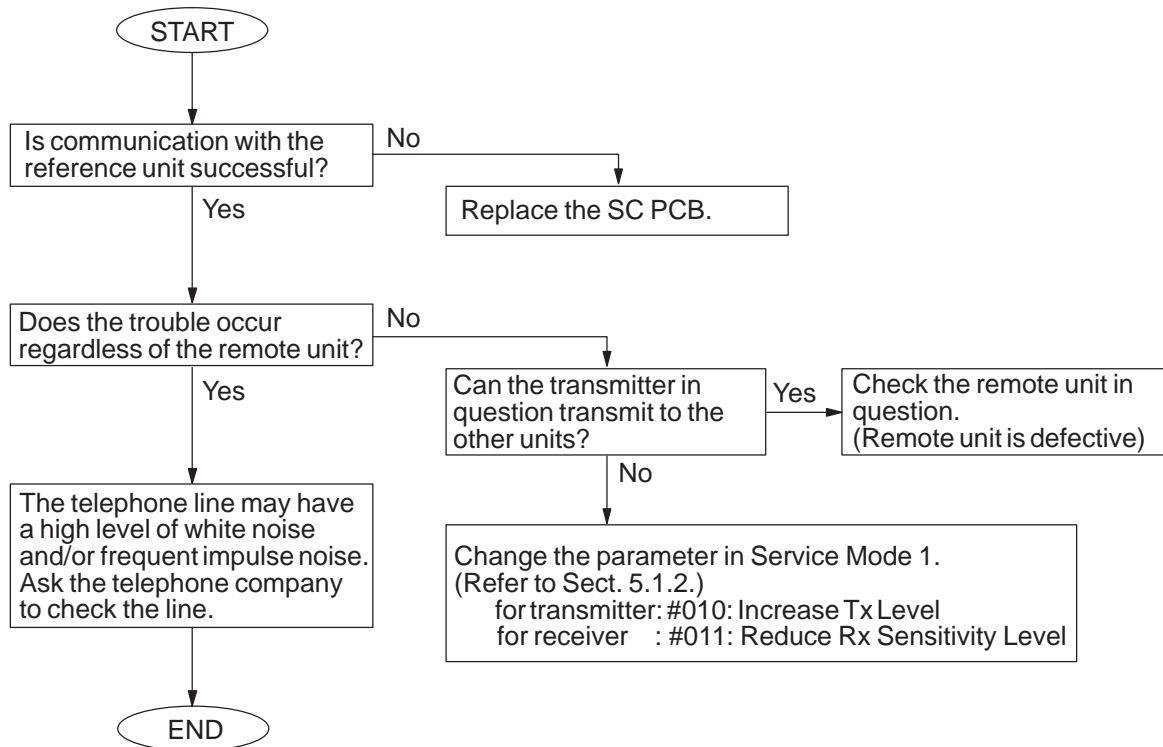

### 4.3.7. Information Codes: 459, 494, 495

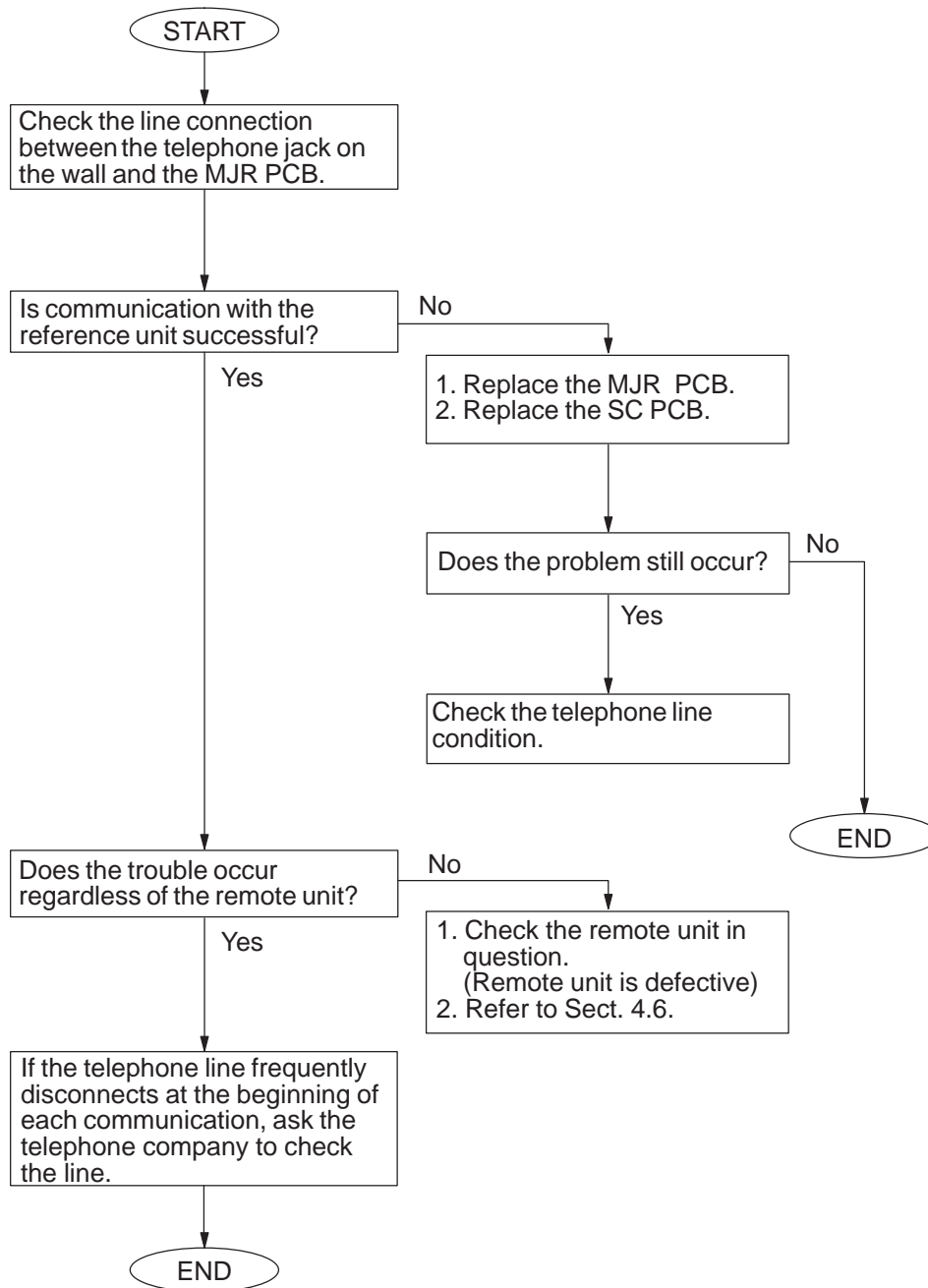



#### 4.3.8. Information Codes: 001, 002, 007 (Recording Paper Jam)

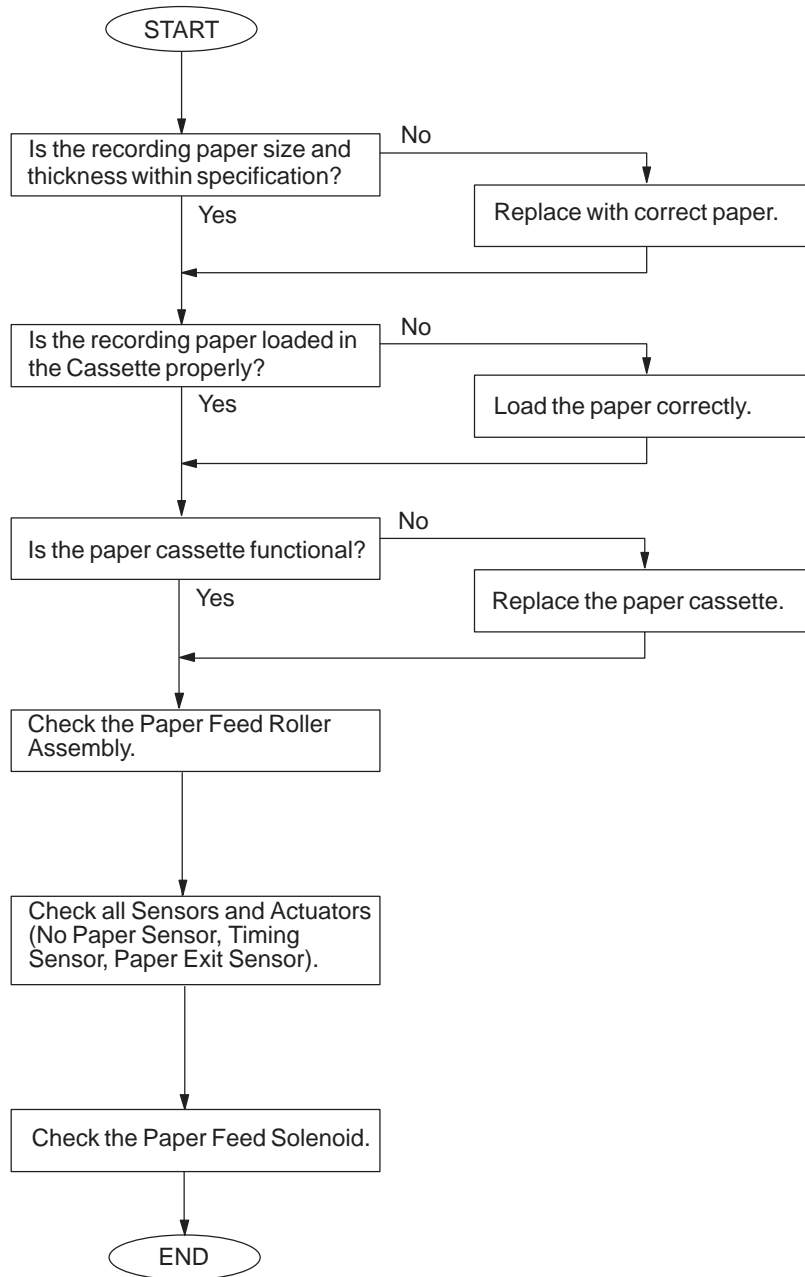

### 4.3.9. Information Code: 010 (No Recording Paper)

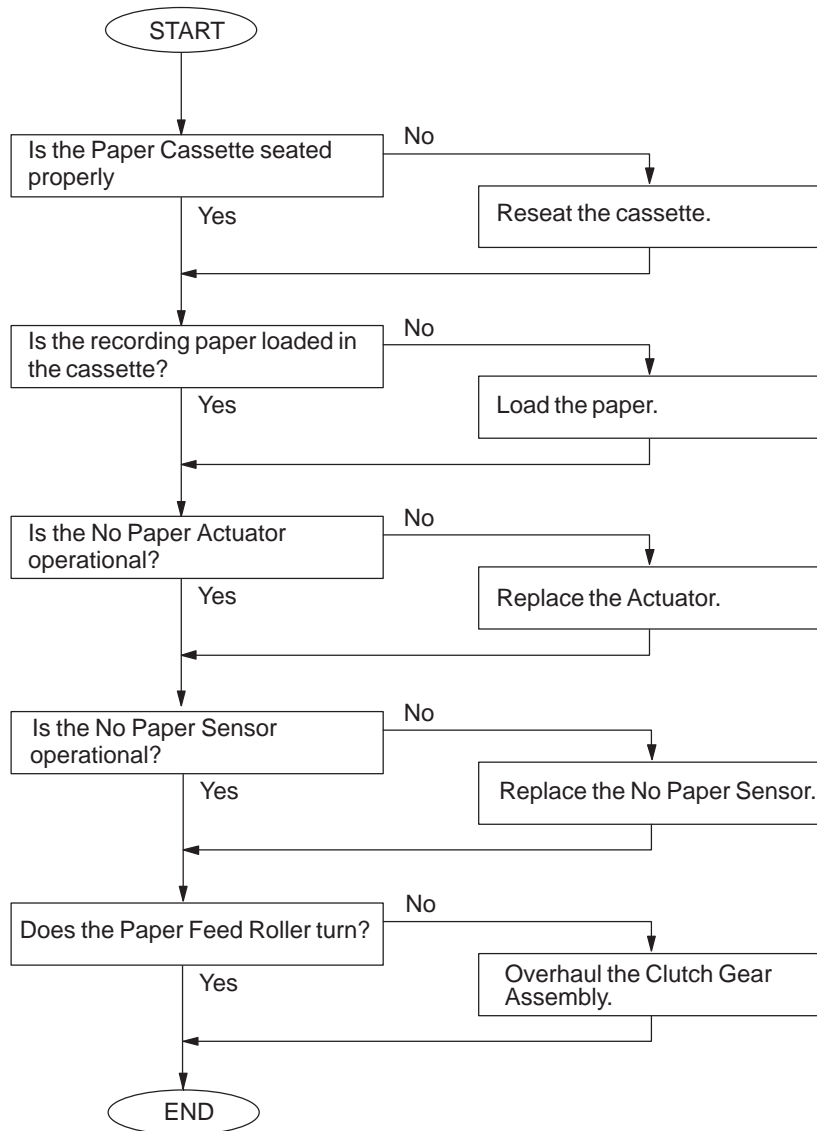

### 4.3.10. Information Codes: 030, 031 (Document Jam)

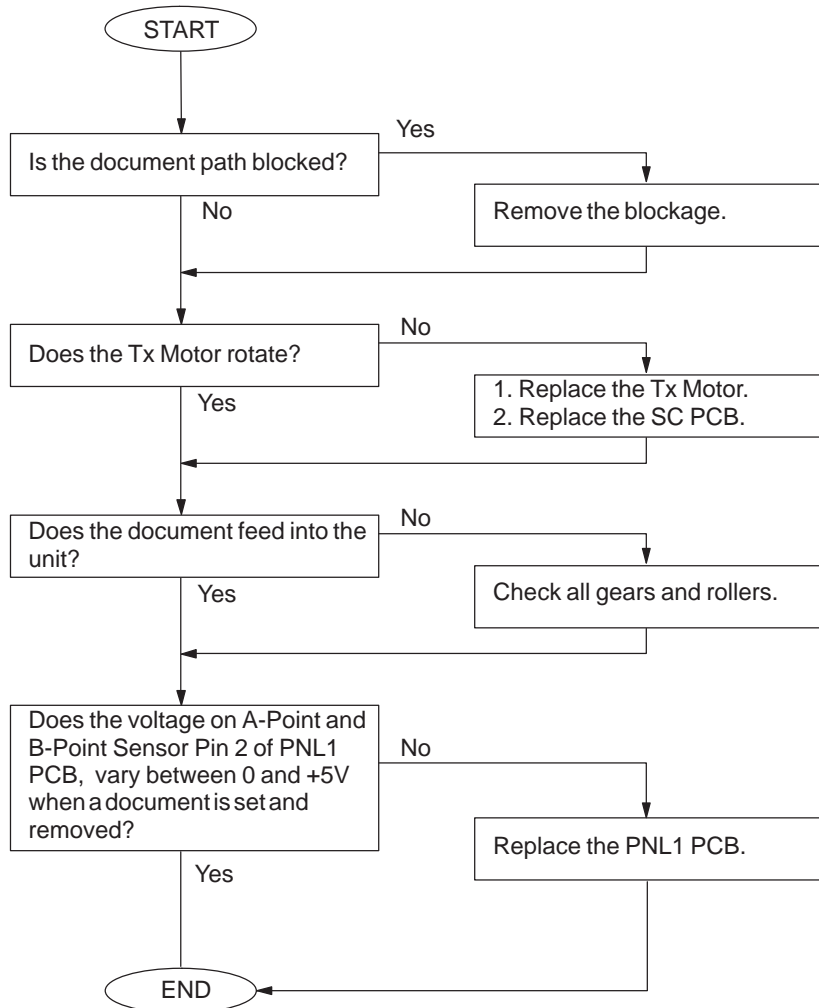

### 4.3.11. Information Code: 630 (Dialing Error)

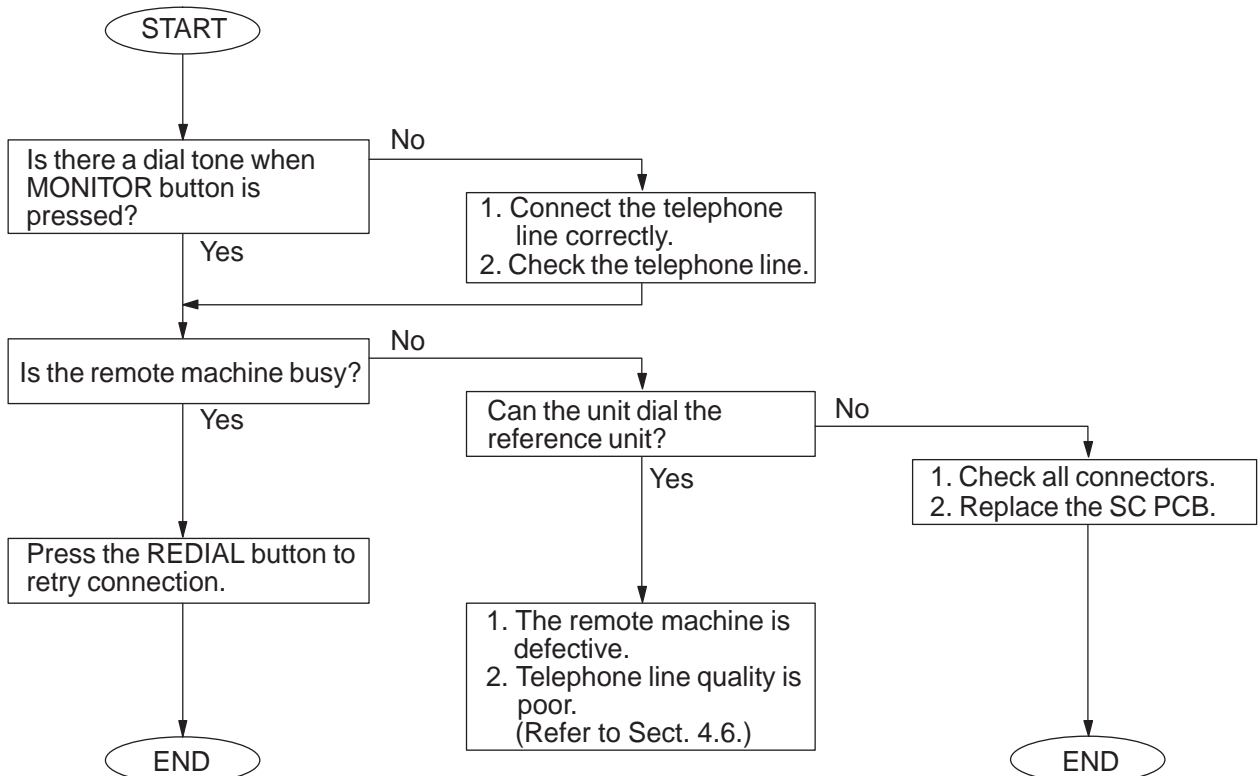

#### 4.3.12. Information Codes: 403, 411, 414, 415 (Polling Operator Trouble)

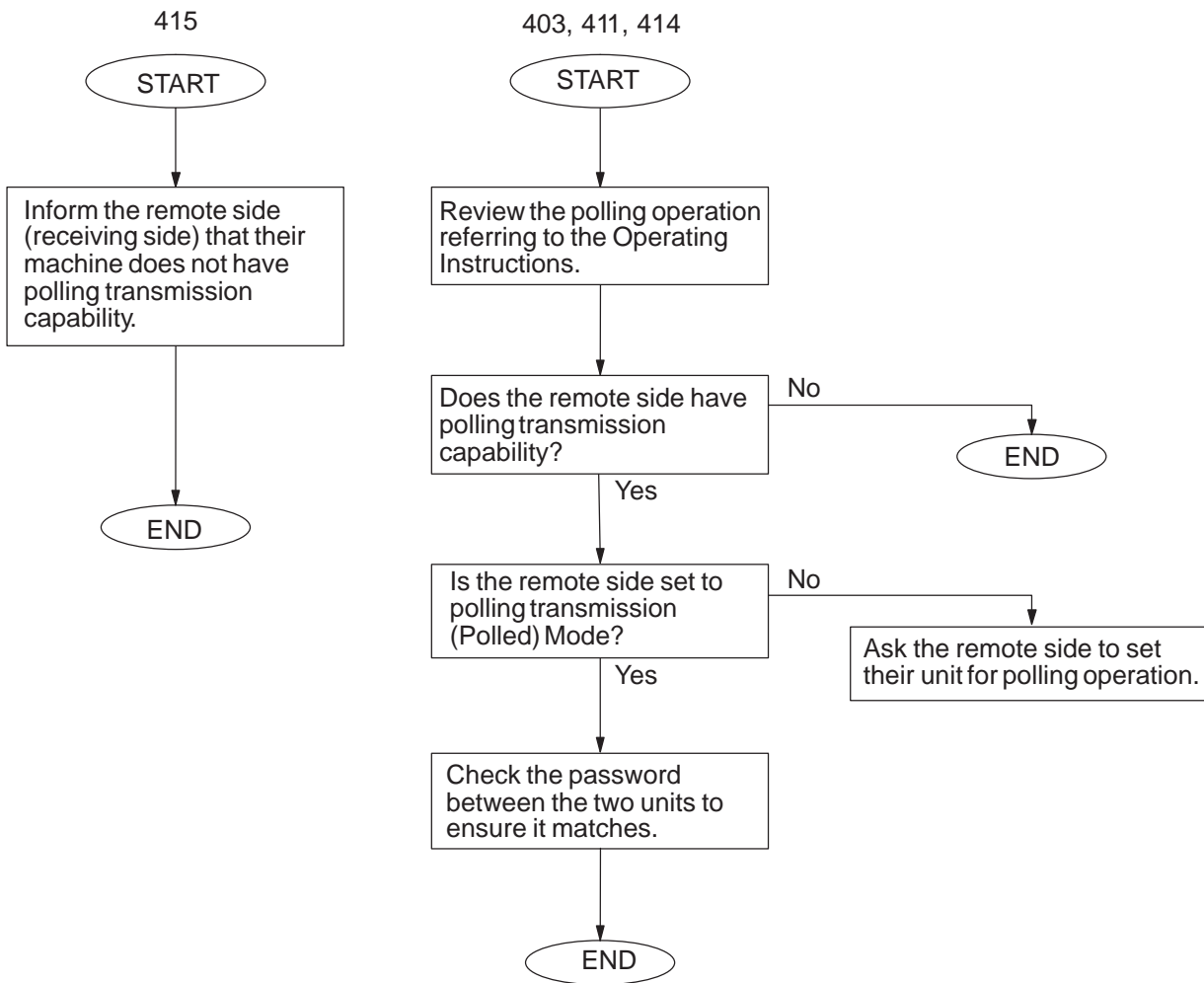

Polling communication with 4-digit password is not an ITU-T Standard feature. If the transmitter and receiver are of different manufacturers, polling communication with password **may not** be possible.

## 4.4. Printed Copy Quality Problems

### 4.4.1. Black Copy

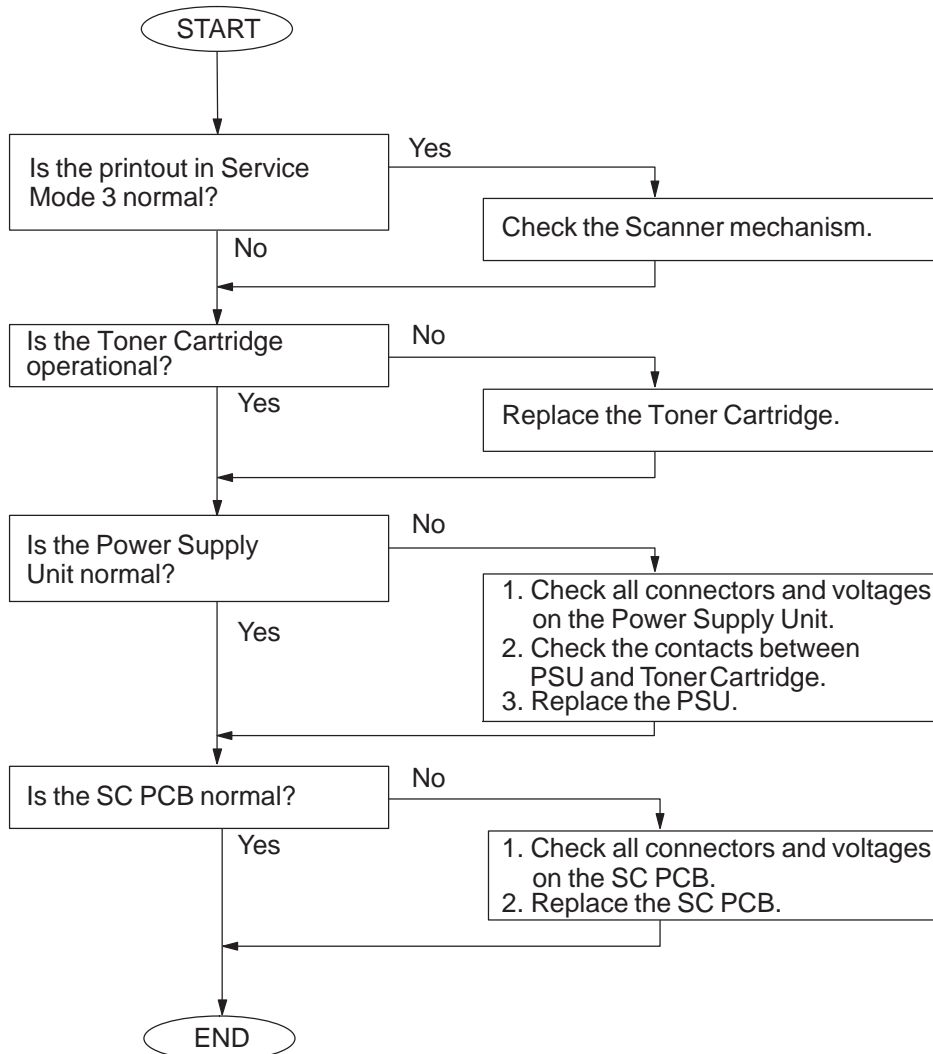
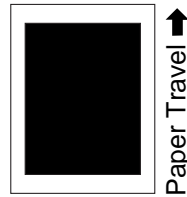

#### 4.4.2. Blank Copy

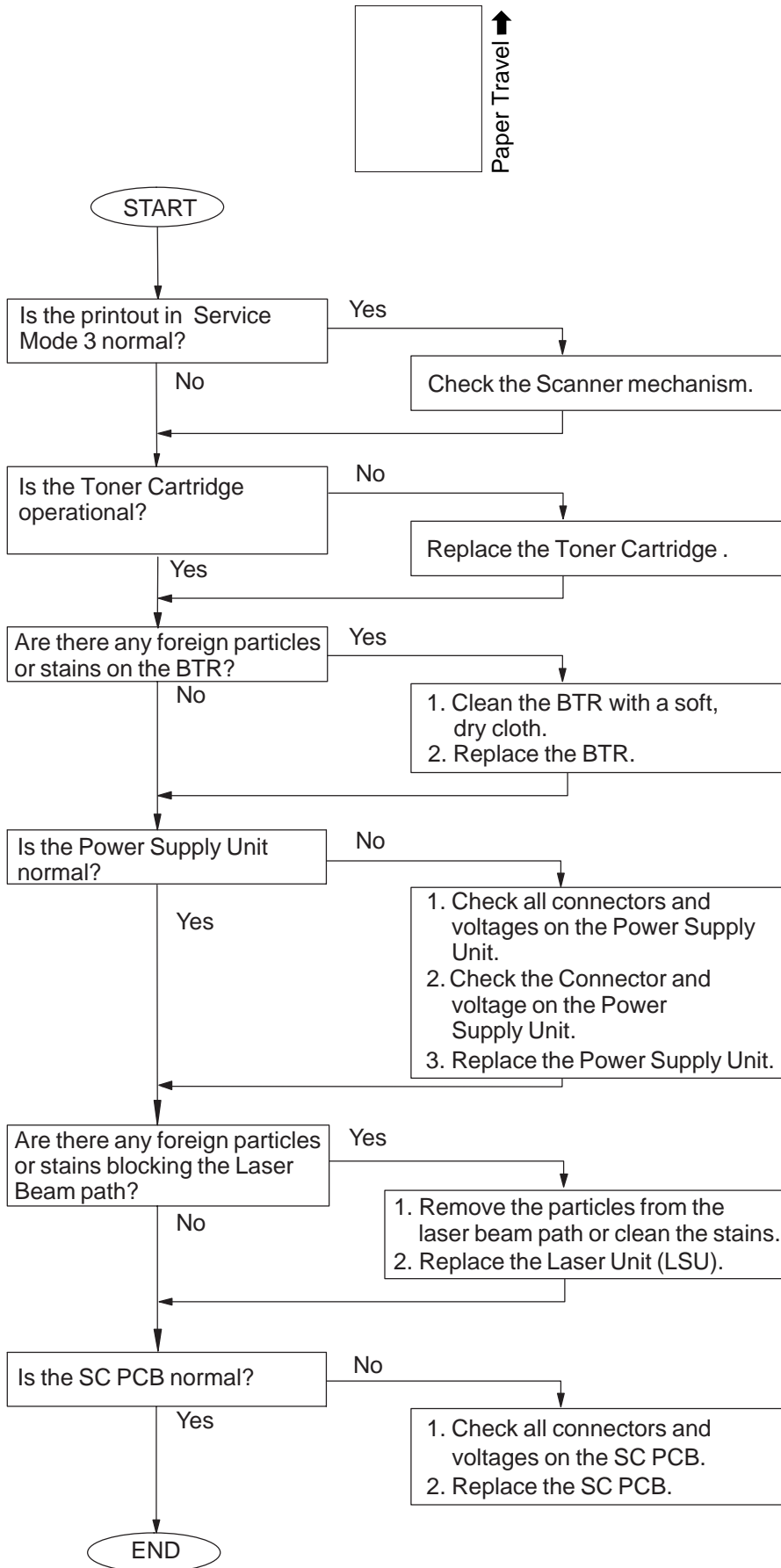

### 4.4.3. Vertical White Lines

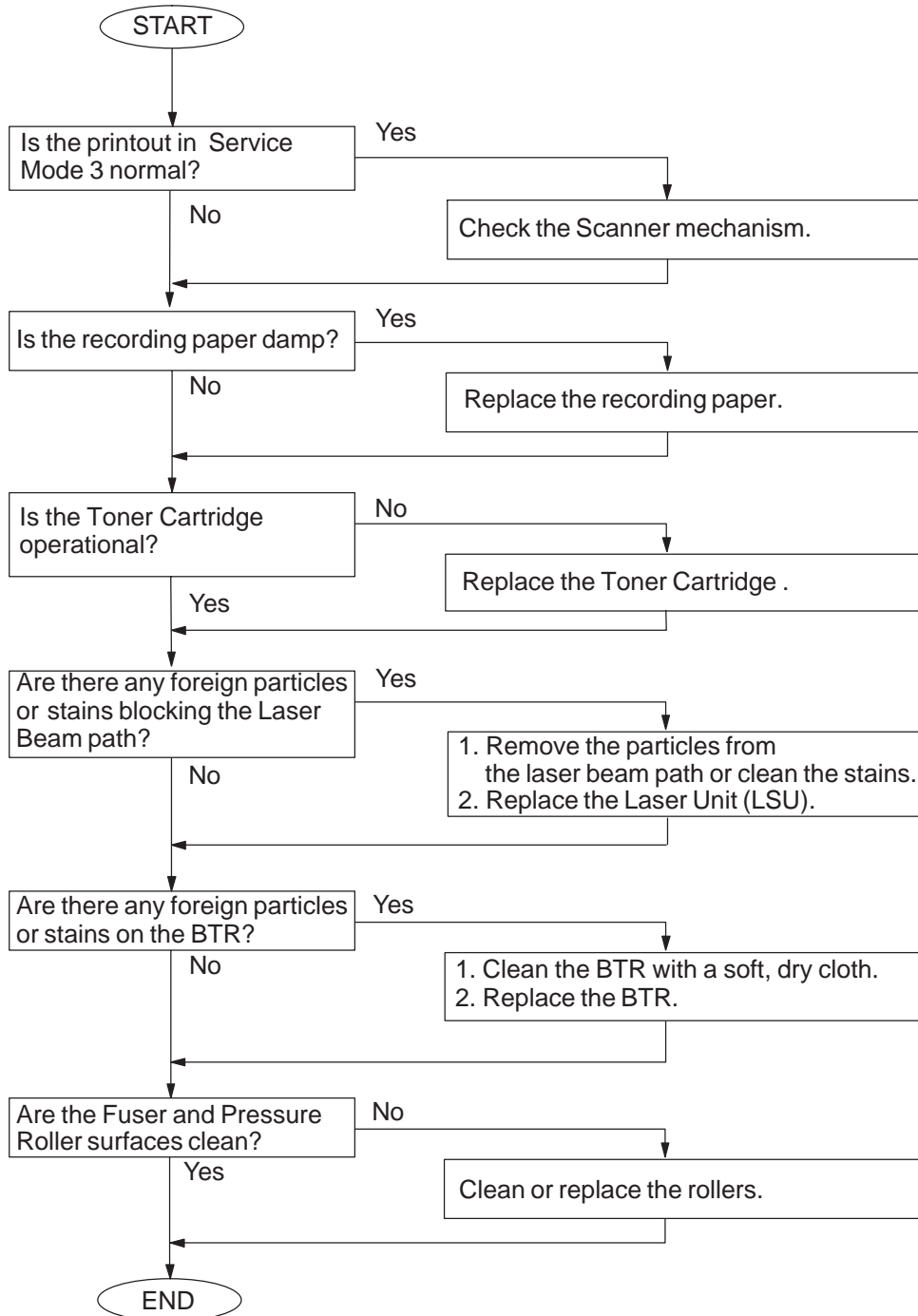
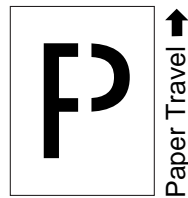

#### 4.4.4. Ghost Images

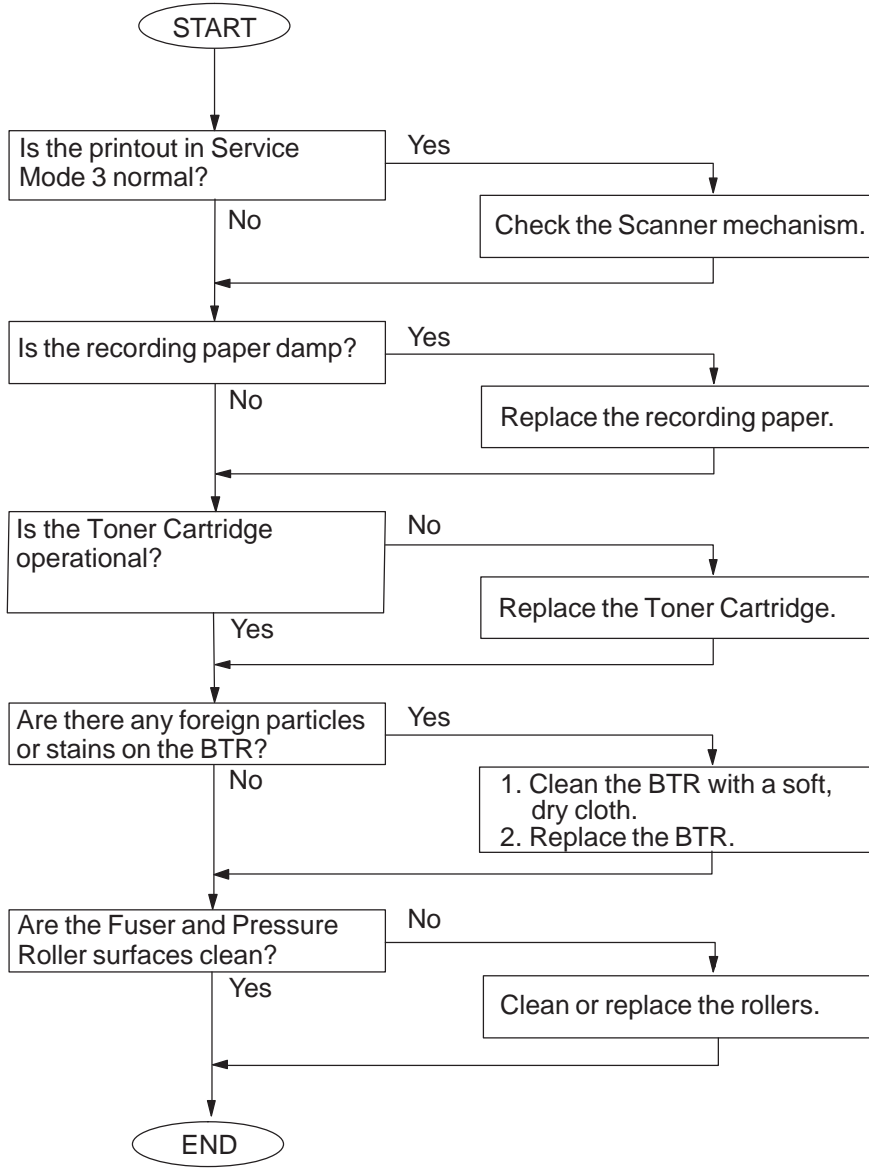
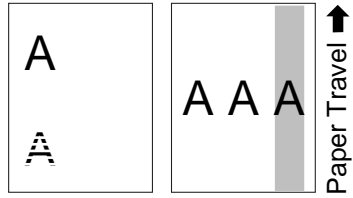



#### 4.4.5. Vertical Dark Lines

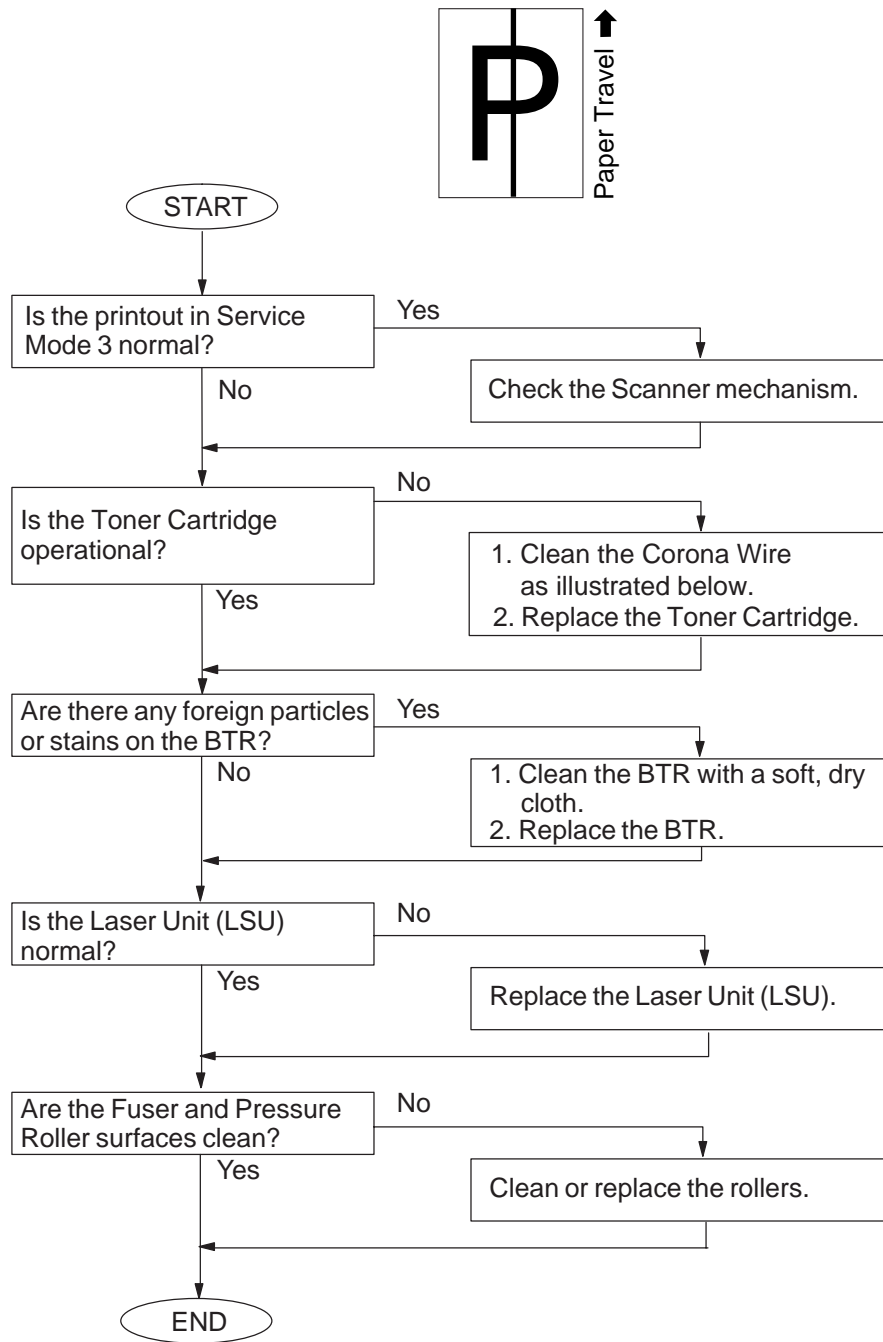

#### 4.4.6. Horizontal Dark Lines

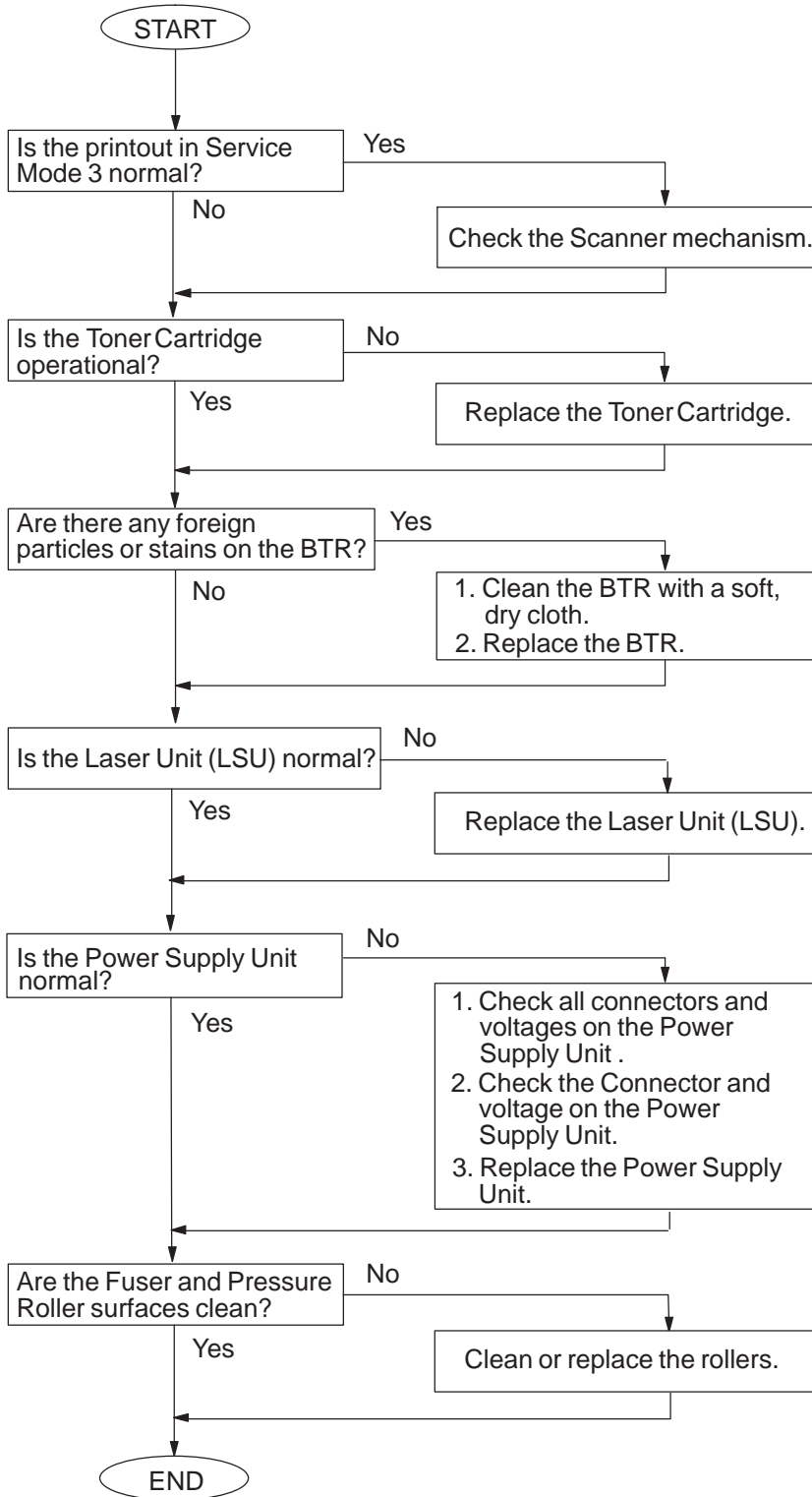
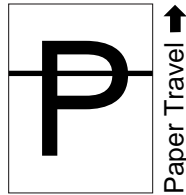

#### 4.4.7. Dark Background

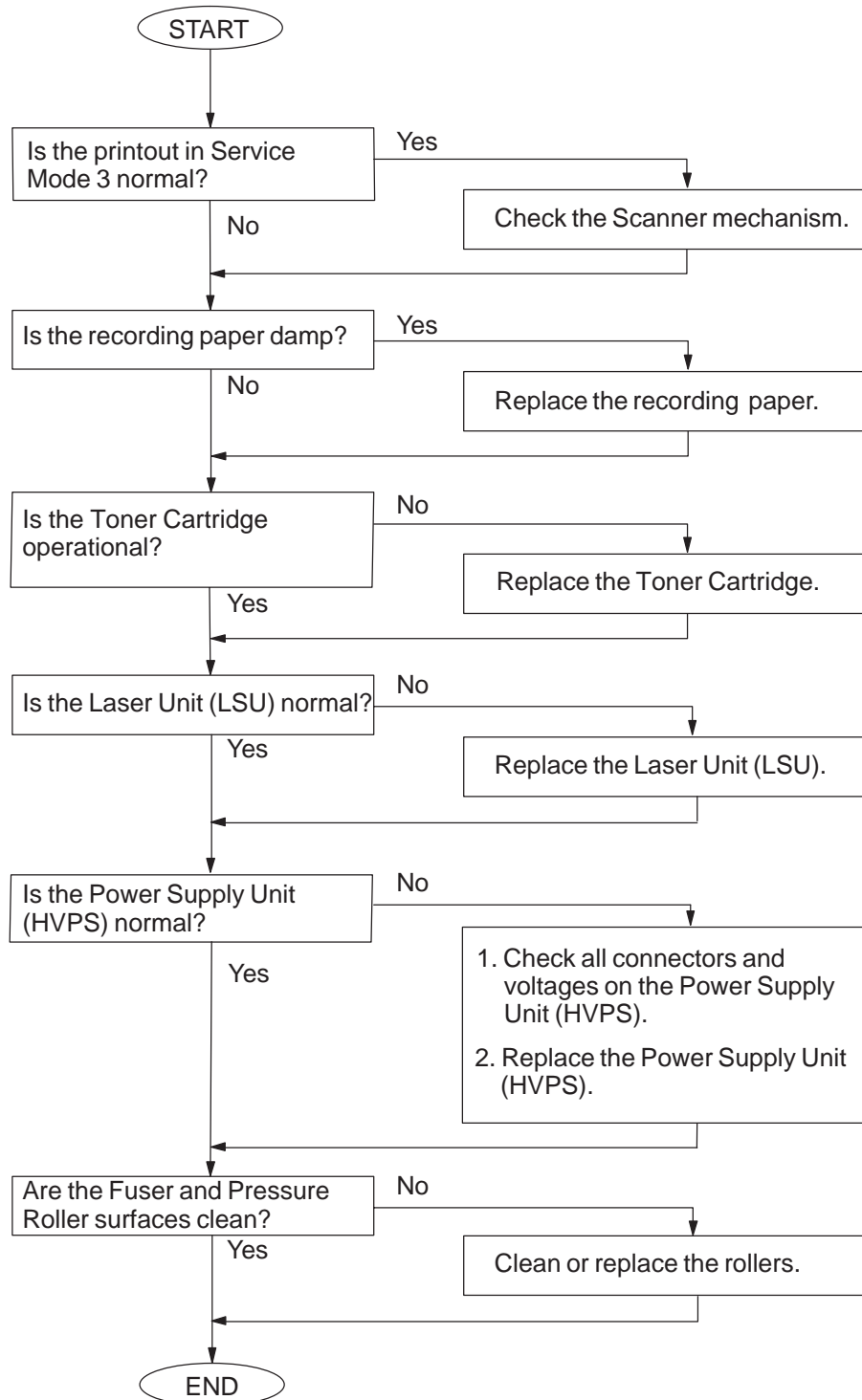
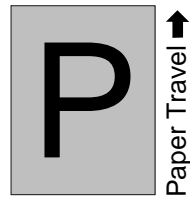

#### 4.4.8. Light Print

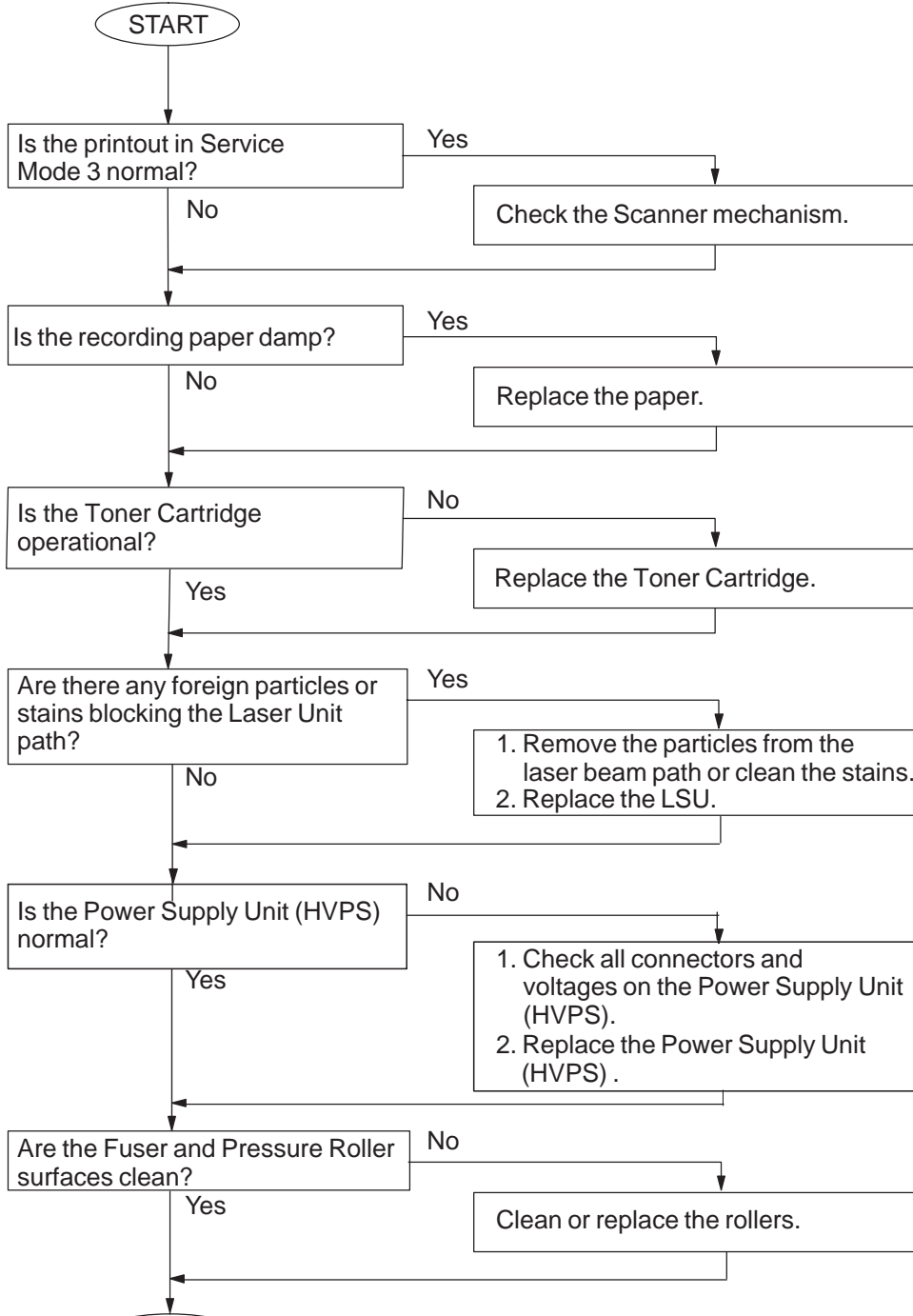
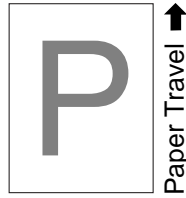

#### 4.4.9. Horizontal White Lines

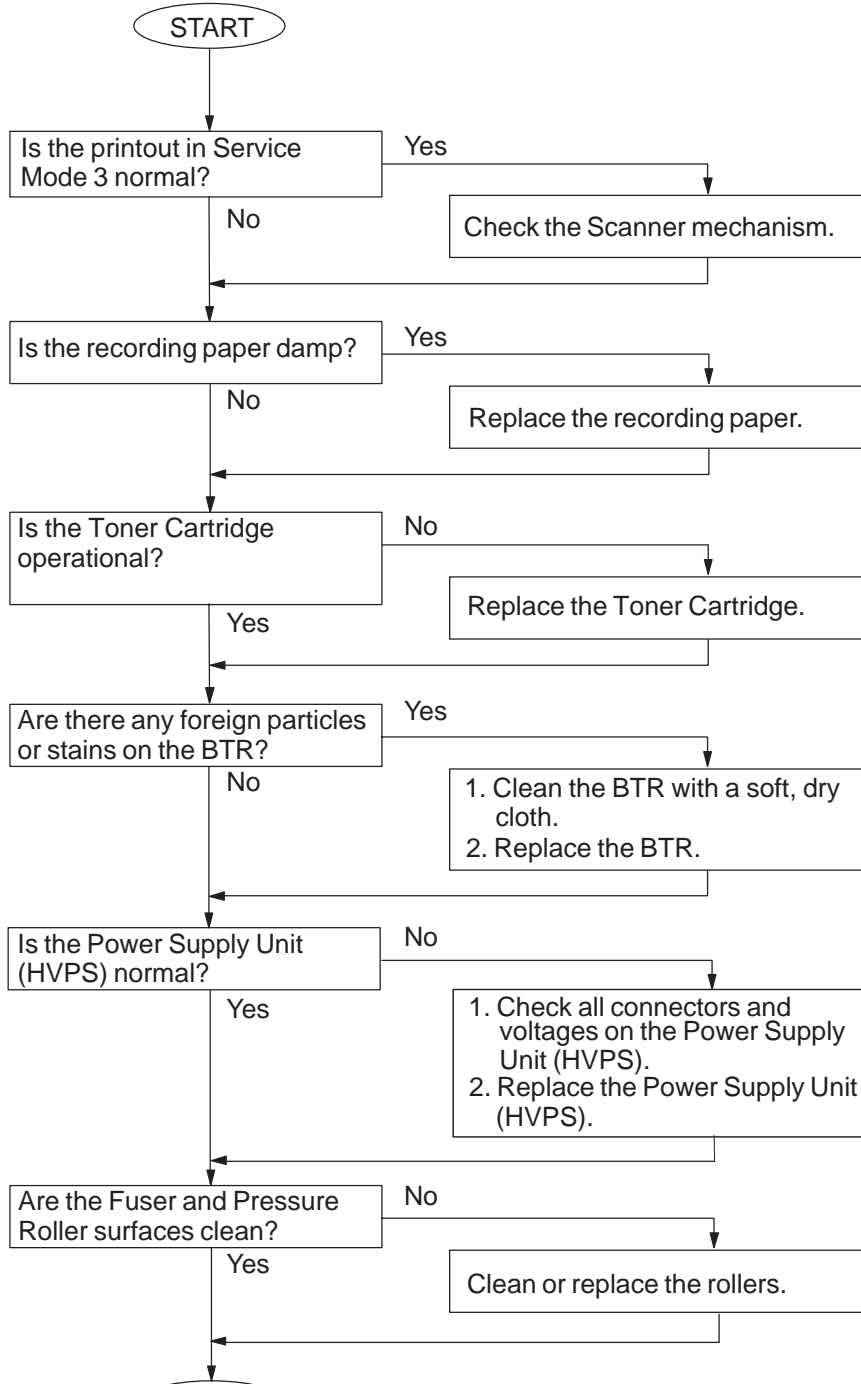
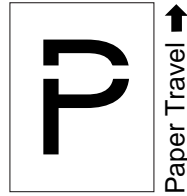

#### 4.4.10. Improper Fusing (Printed image does not bond to the paper)

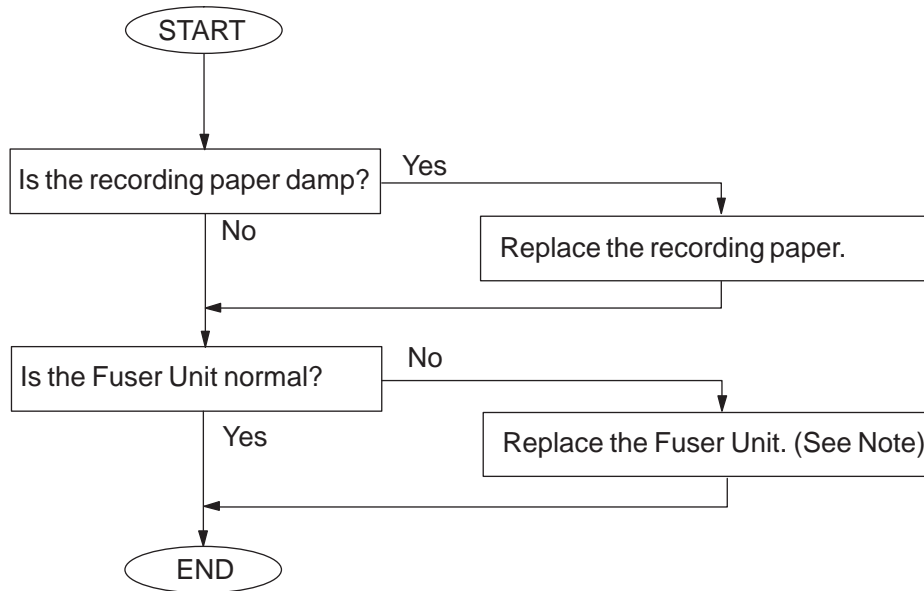
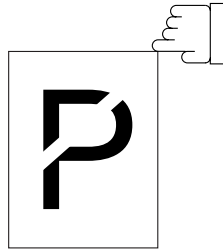

**Note:** Replace the entire Fuser Unit when the Thermostat, the Thermal Fuse or the Thermistor Assembly breakdown into an open-circuit.

#### 4.4.11. Voids in Solid Areas

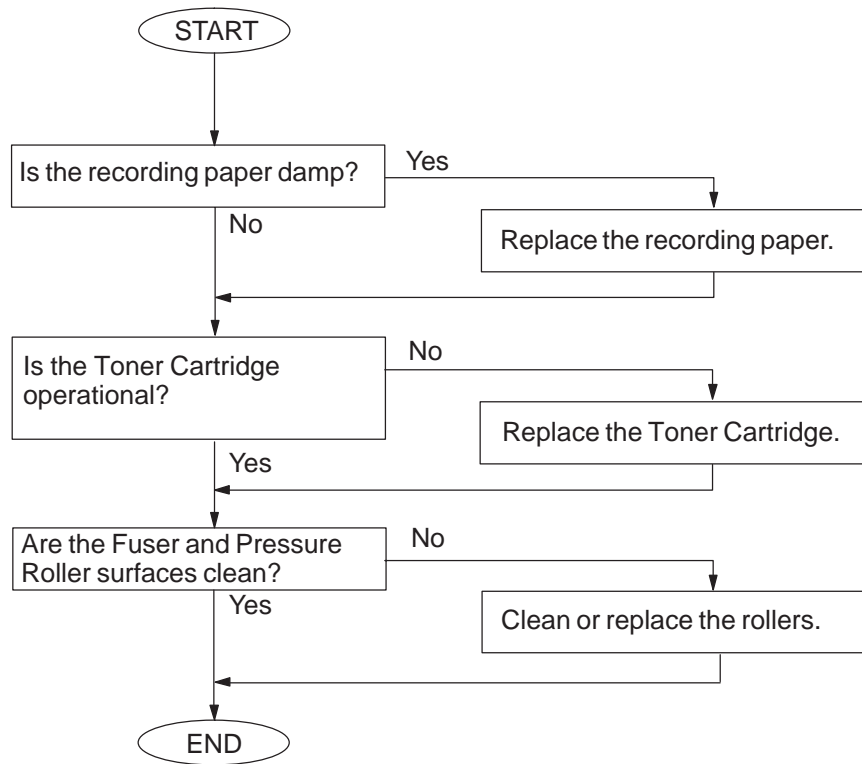
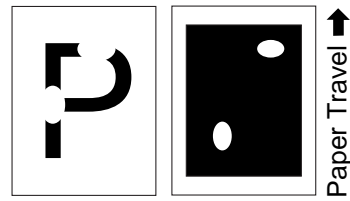

#### 4.4.12. Black Dots

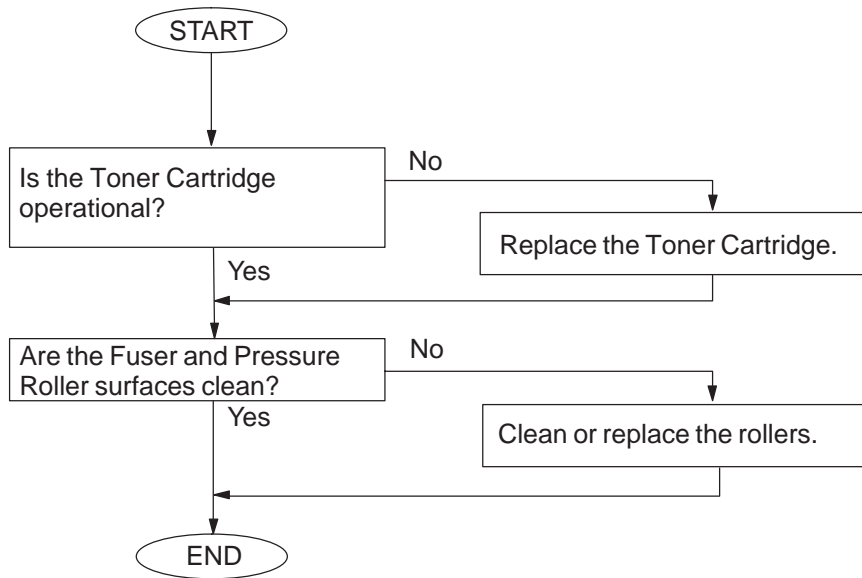
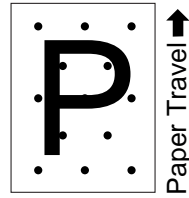



#### 4.4.13. Recording Paper Creases

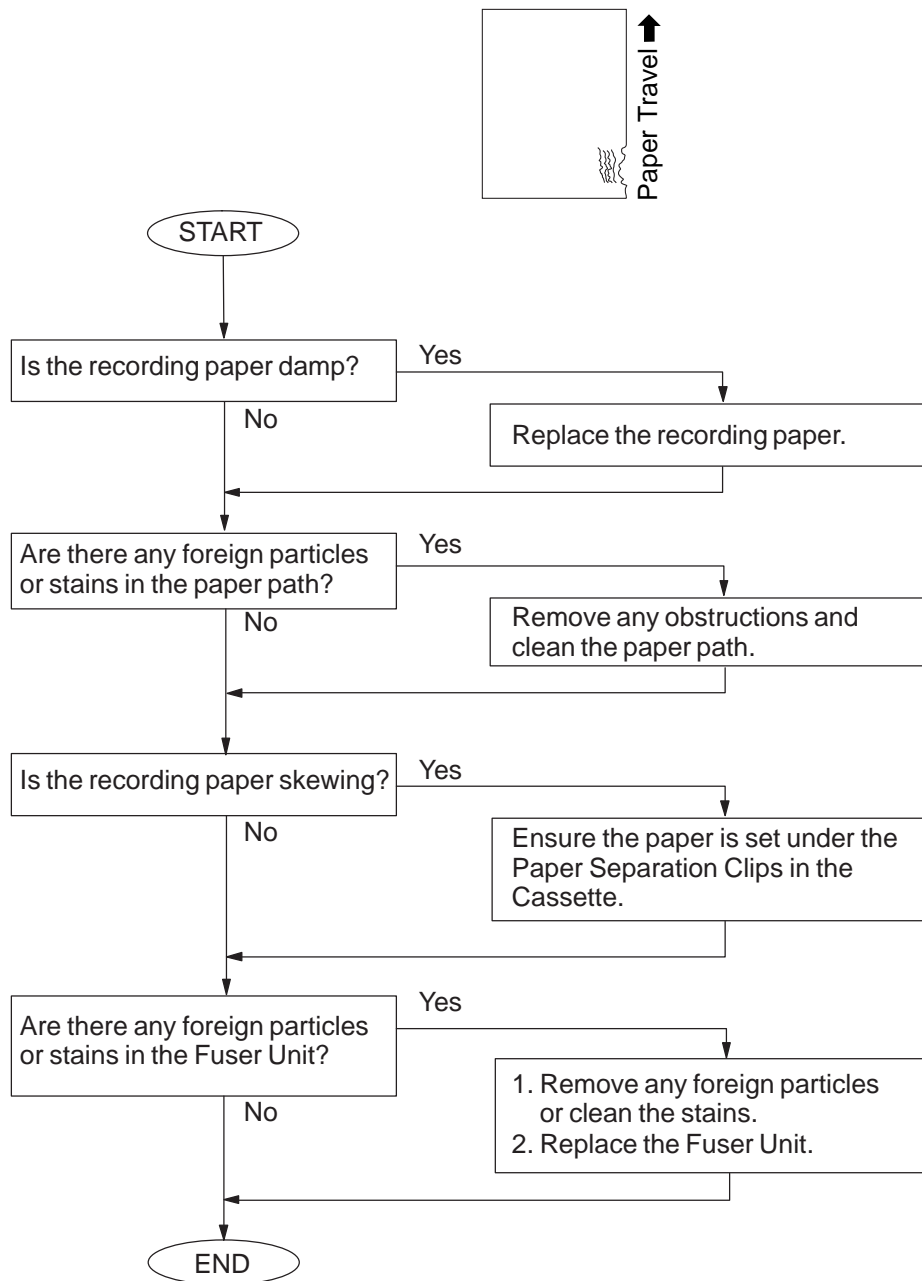

#### 4.4.14. Poor Printed Copy Quality

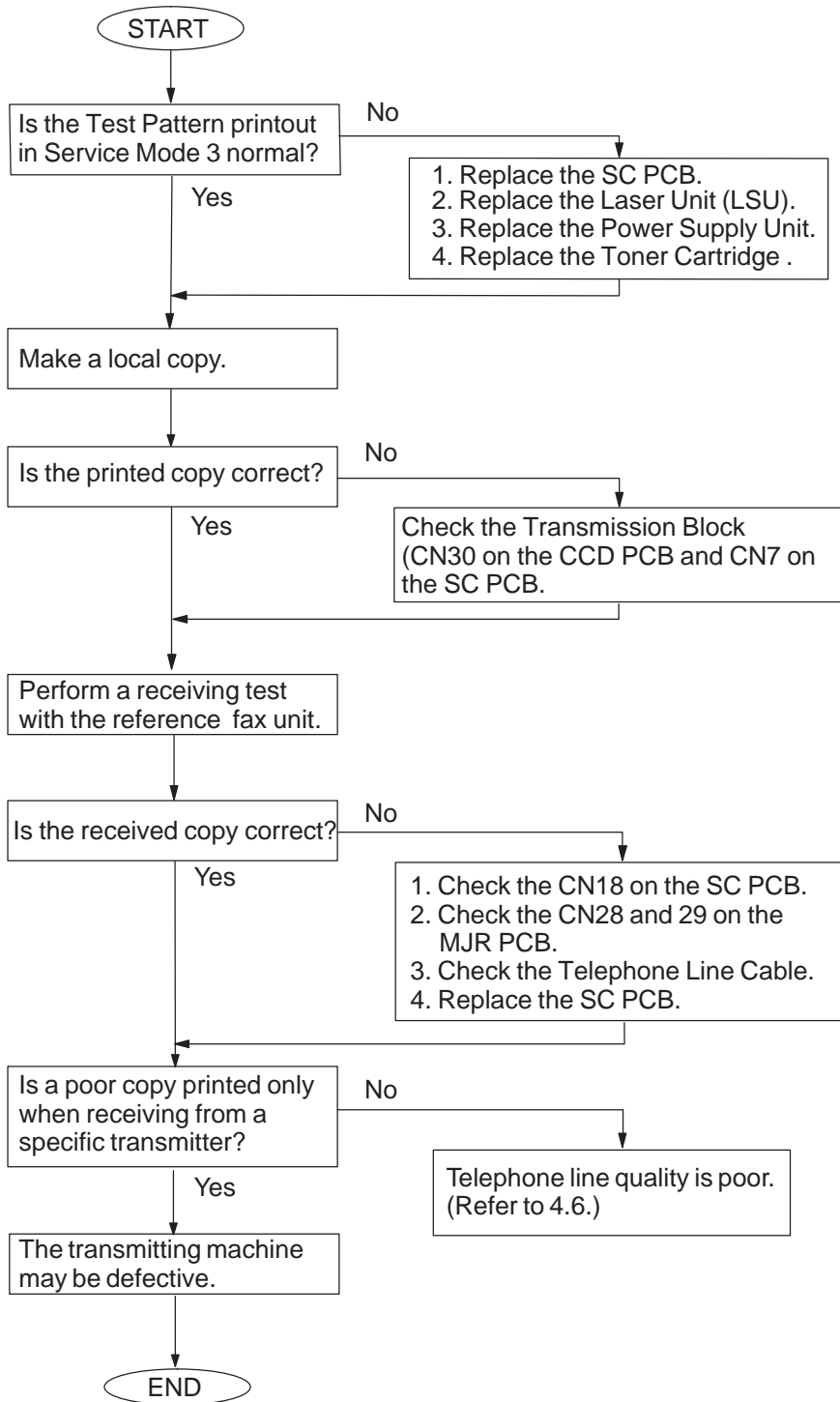

#### 4.4.15. Abnormal Printing

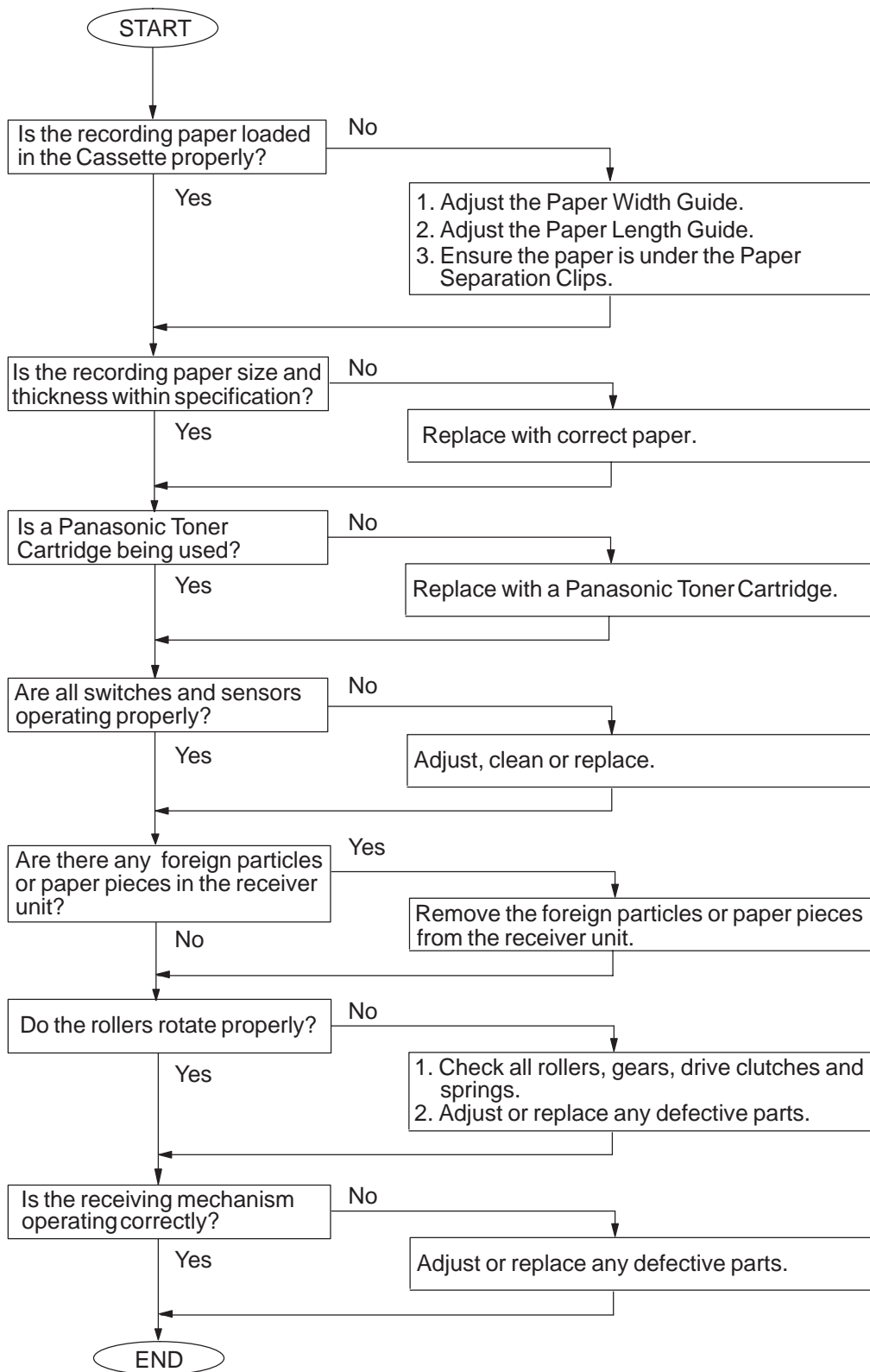

#### 4.4.16. Scanned Copy Quality Problems

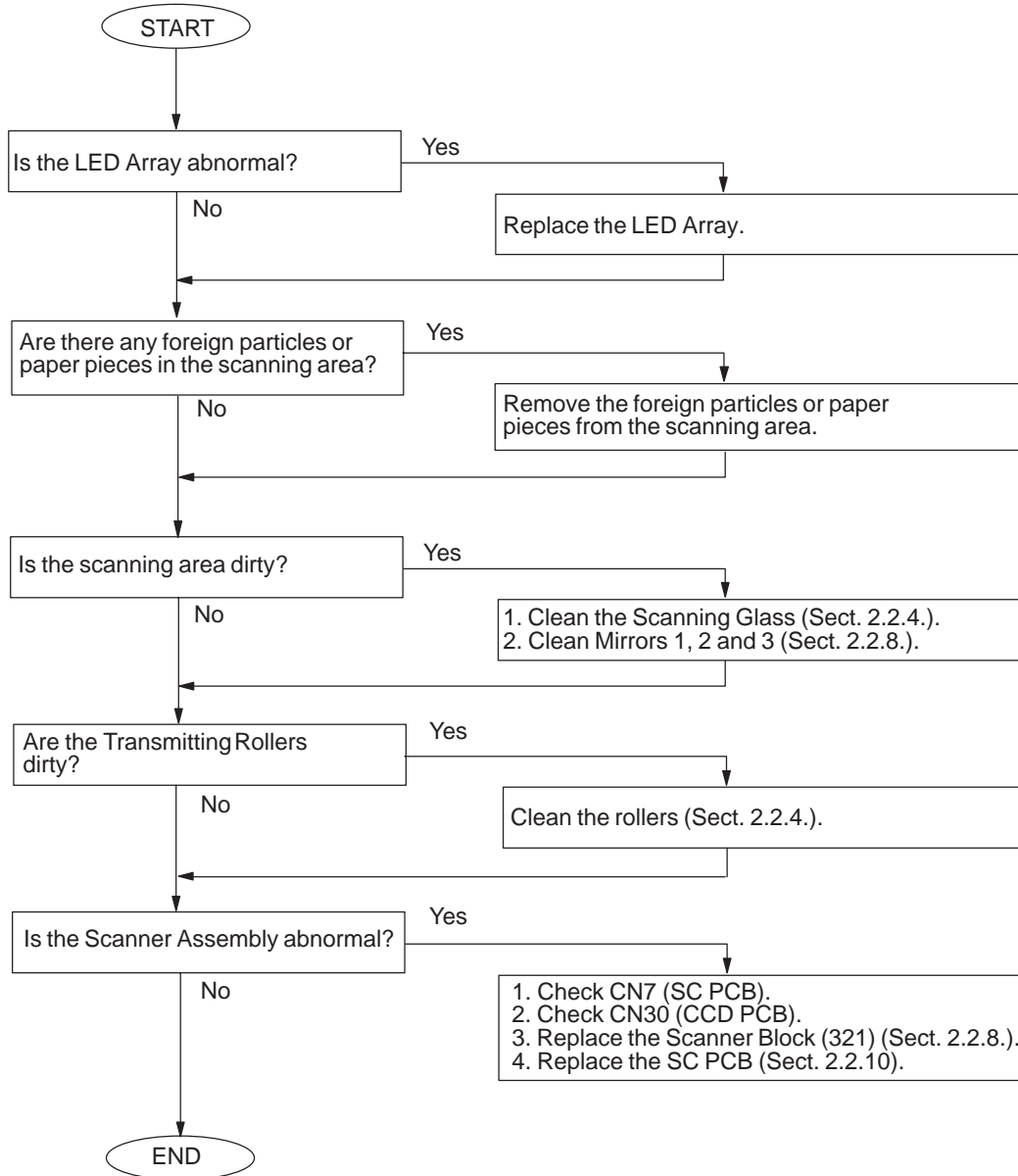

## 4.5. Document Feeder (ADF)

### 4.5.1. No Document Feed

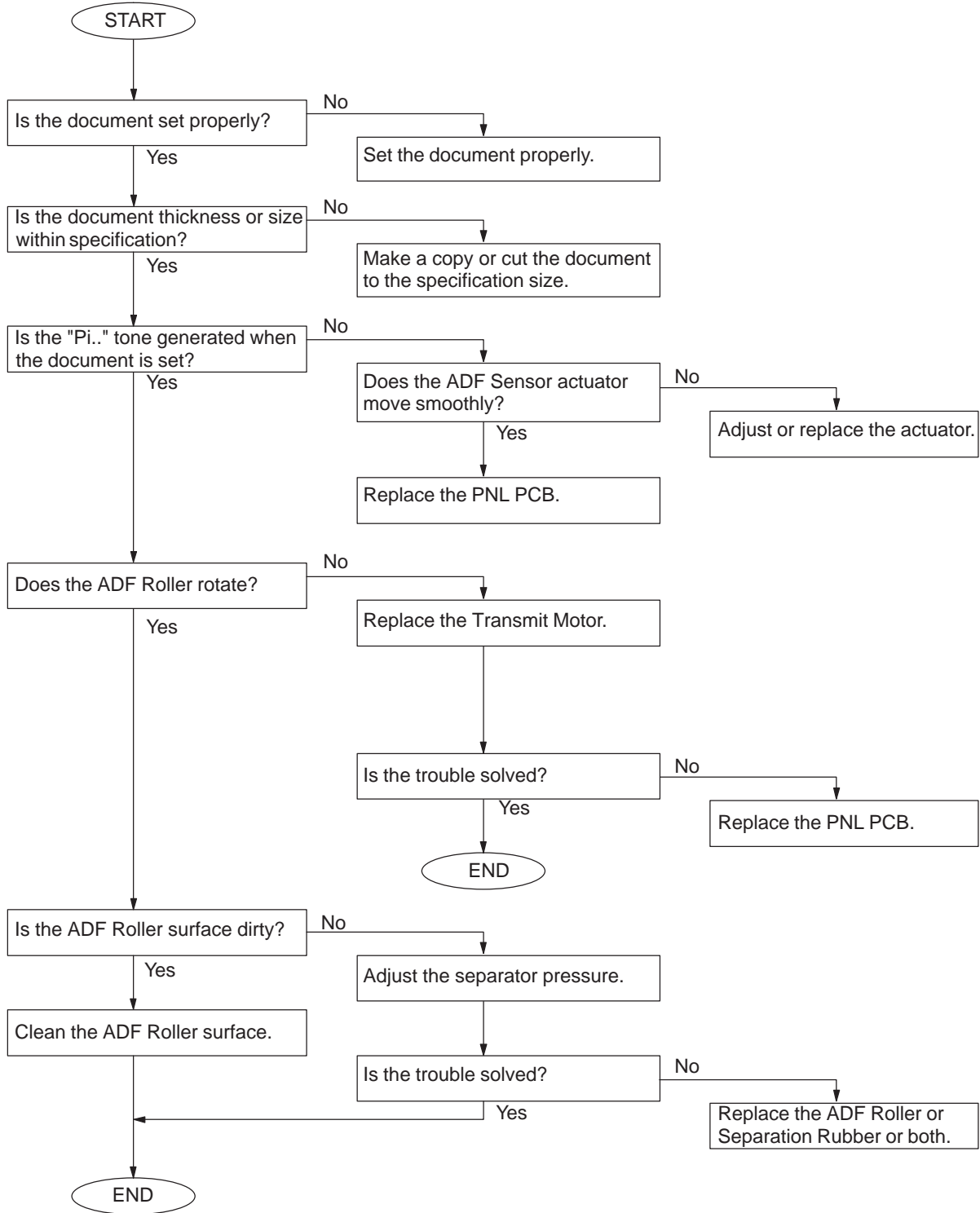

## 4.5.2. Document does not feed or Multiple feeds

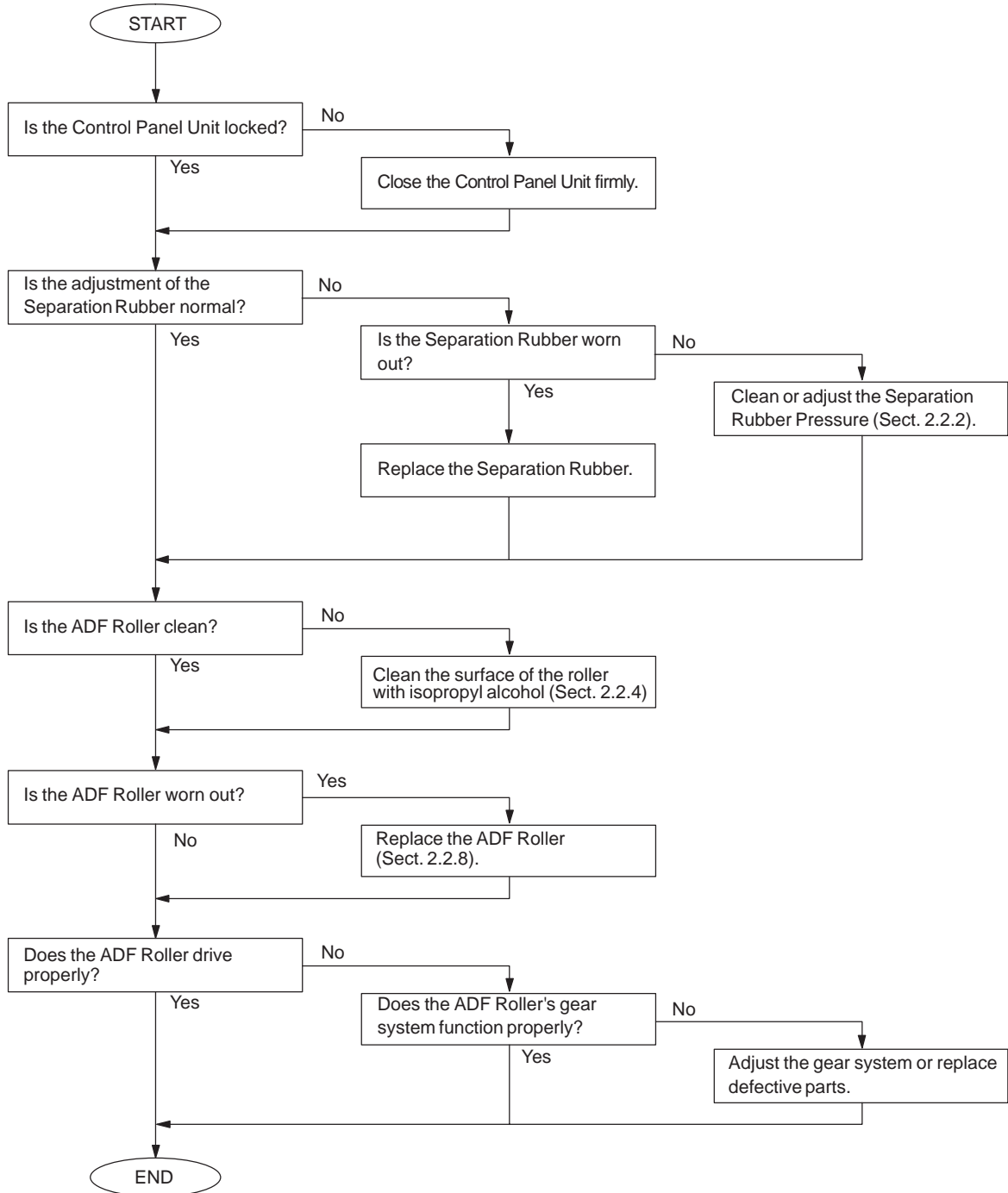

### 4.5.3. Document Jam (030) or Skew

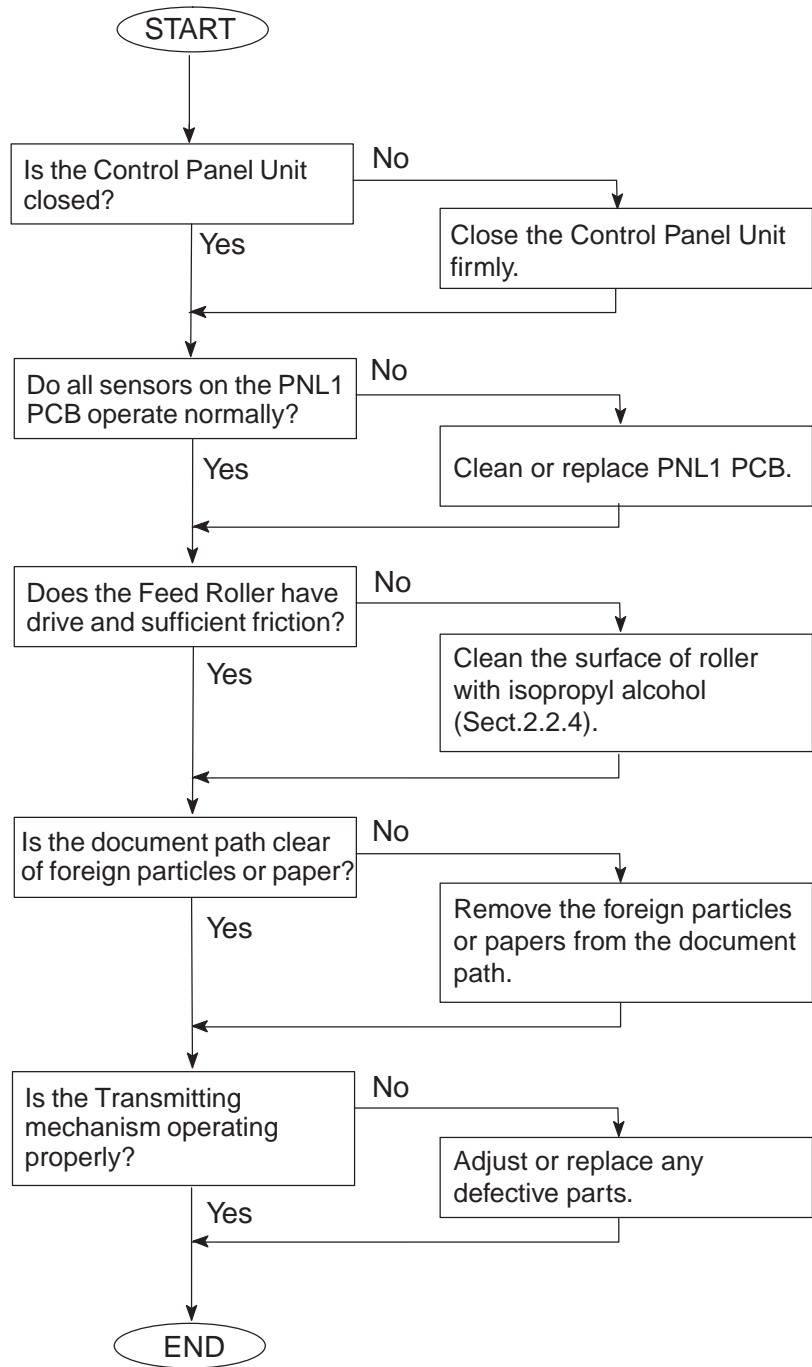

## 4.6. Communications

This section explains general troubleshooting procedures for the 400 series of Information Codes. These errors are primarily caused by poor telephone line quality (loss, noise, echo, etc.). This unit is furnished with Service Mode 1 to assist in troubleshooting line quality problems.

It is suggested that both the transmitting unit and receiving unit be adjusted. This section gives relevant parameters in Service Mode 1 for the transmitting and receiving sides. If no improvement is realized after the parameters are adjusted, it is recommended that the parameters be returned to the default settings.

### 4.6.1. Communication Trouble

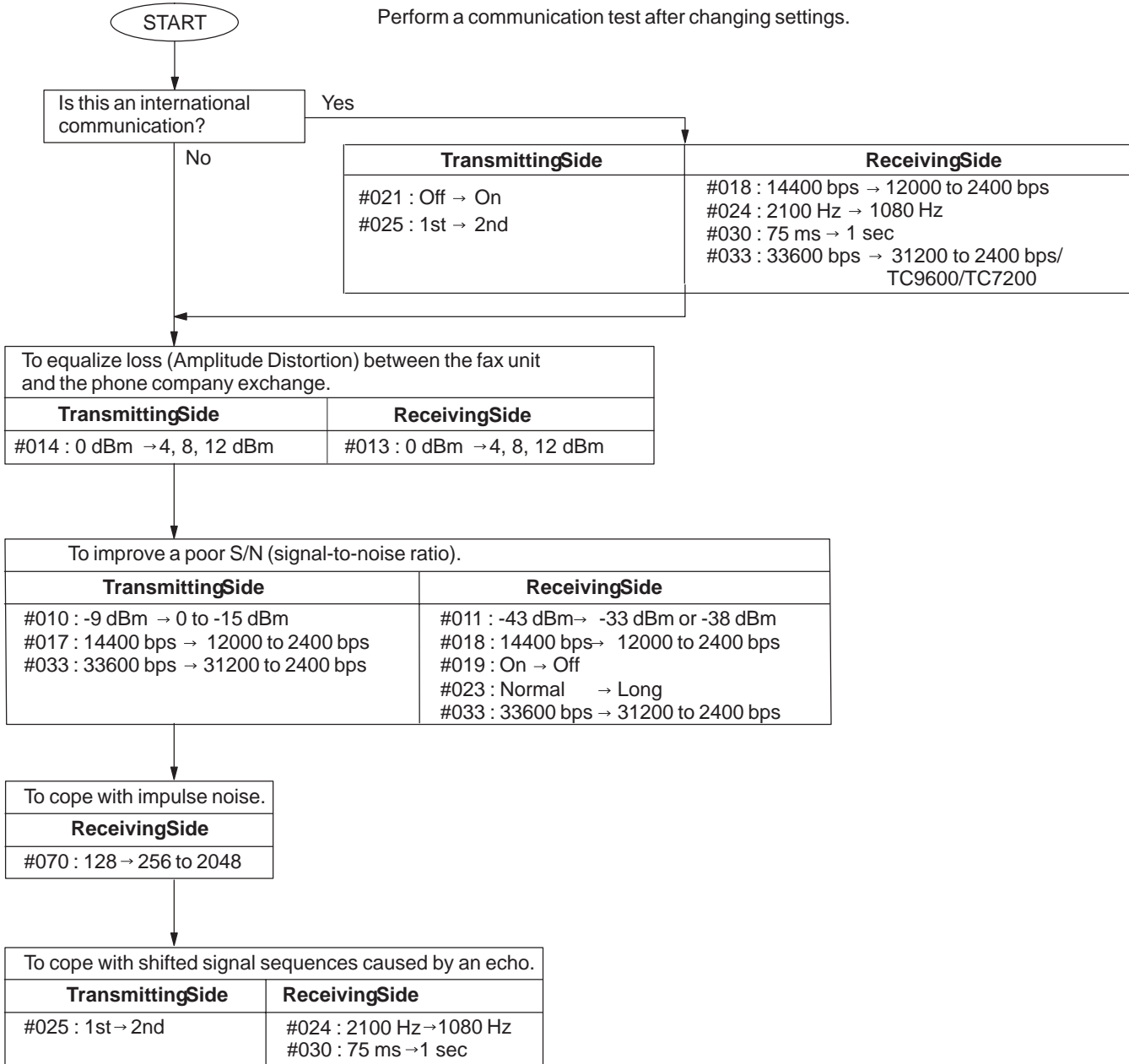



### 4.6.2. Poor Transmitted Copy Quality

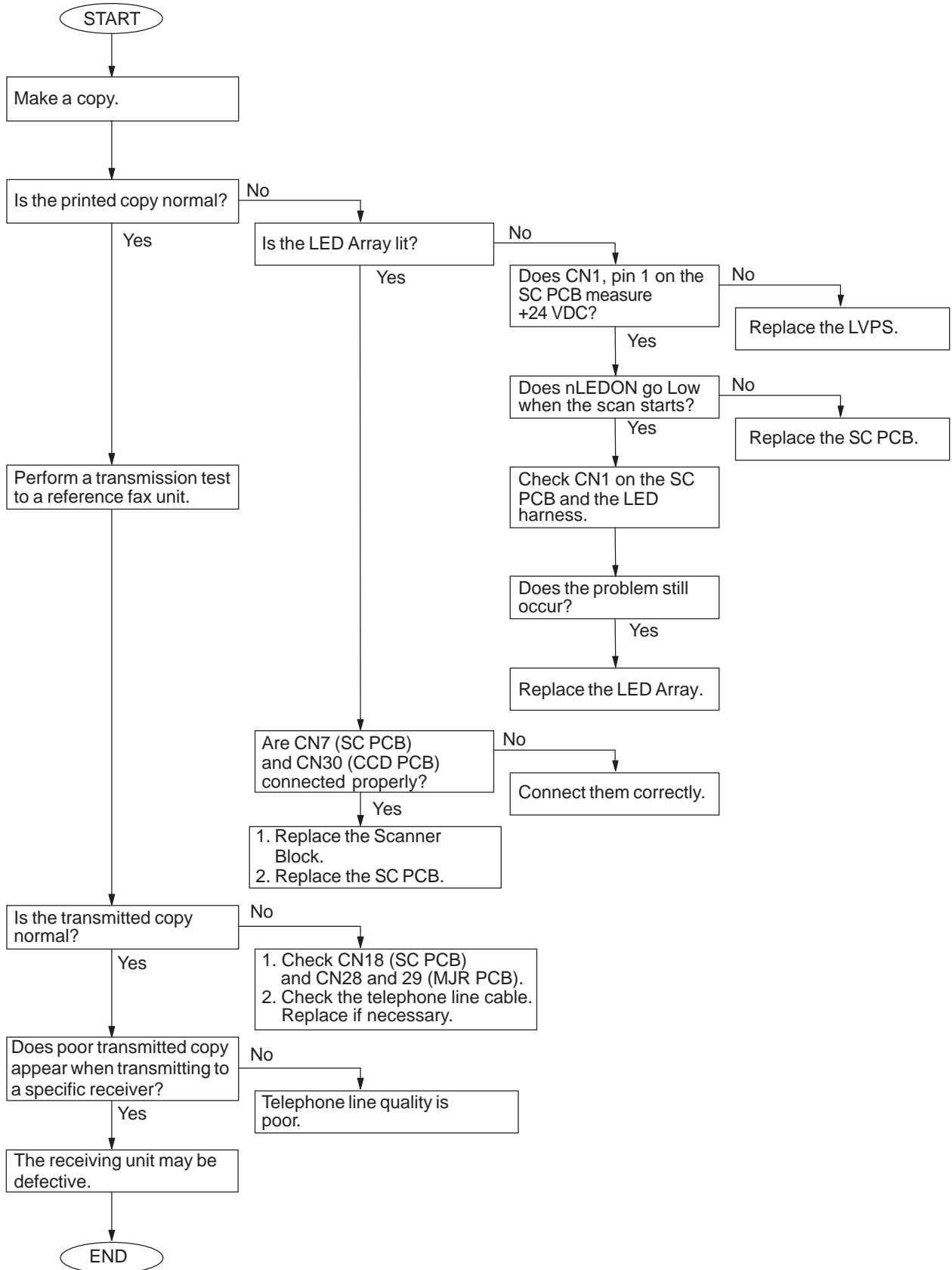

### 4.6.3. Dialing Problems

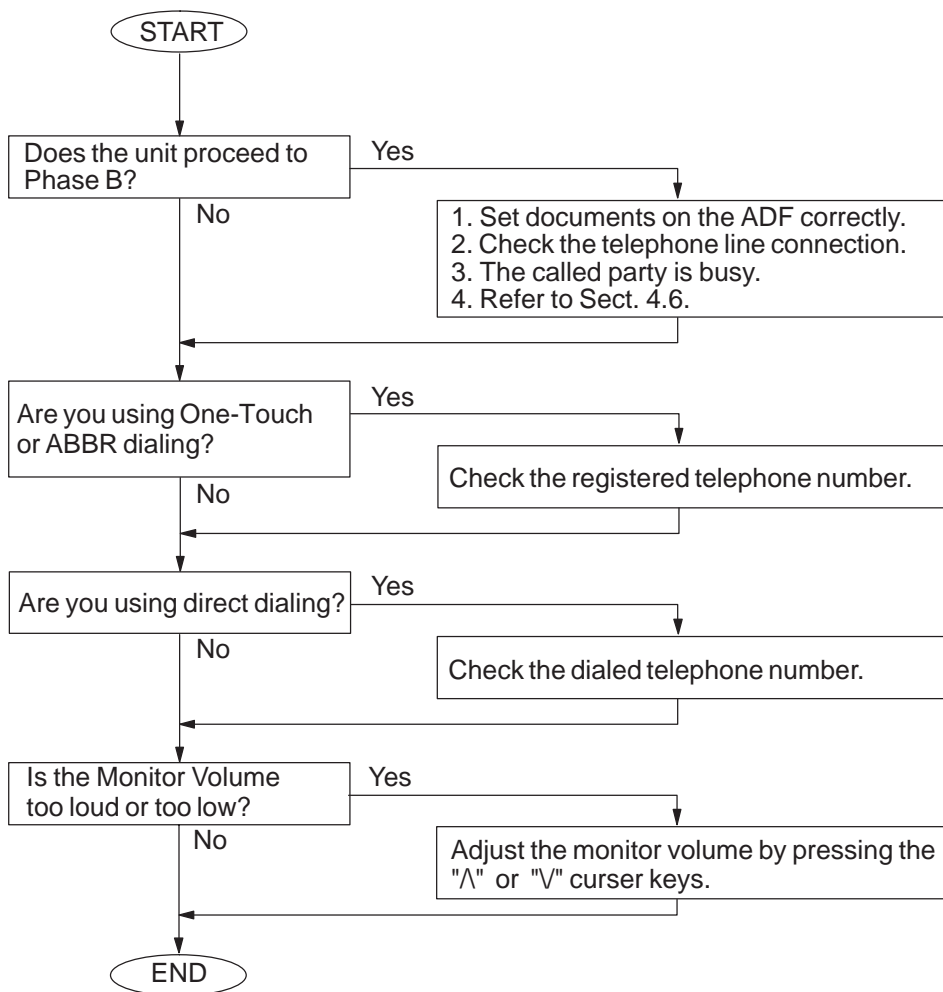

#### 4.6.4. Transmission Problems

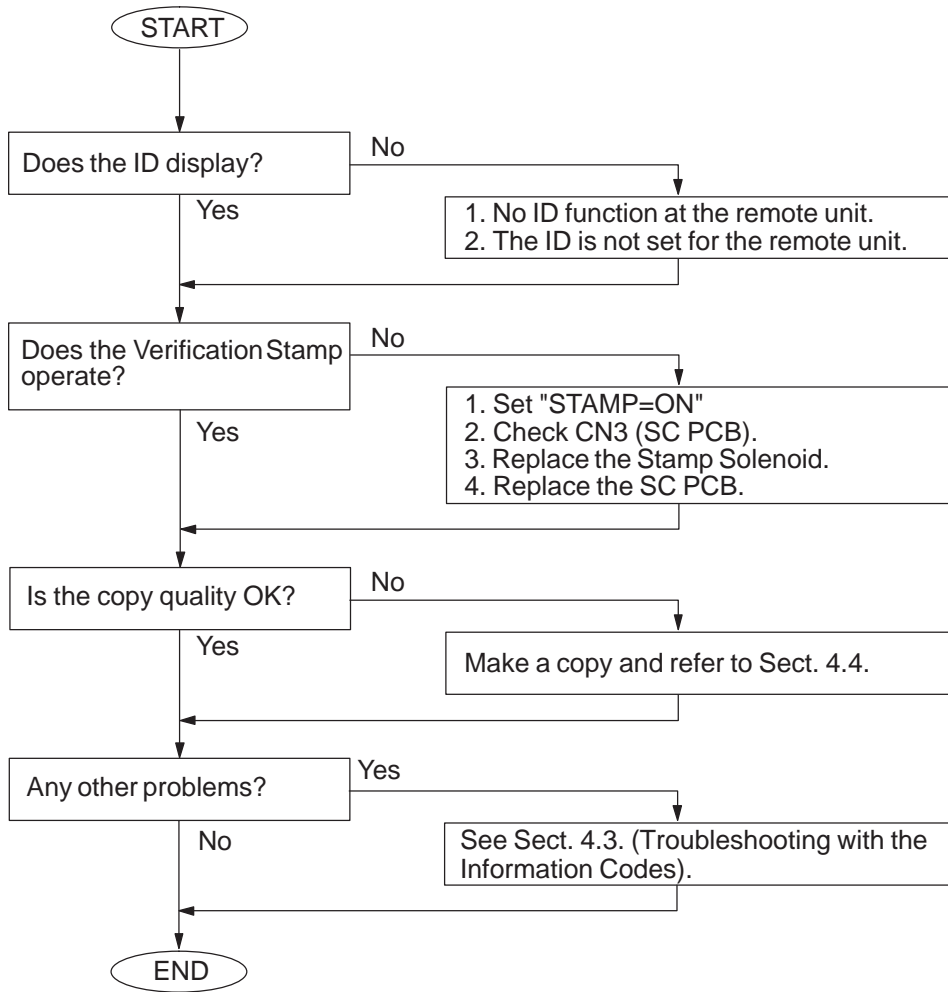

#### 4.6.5. Reception Problems

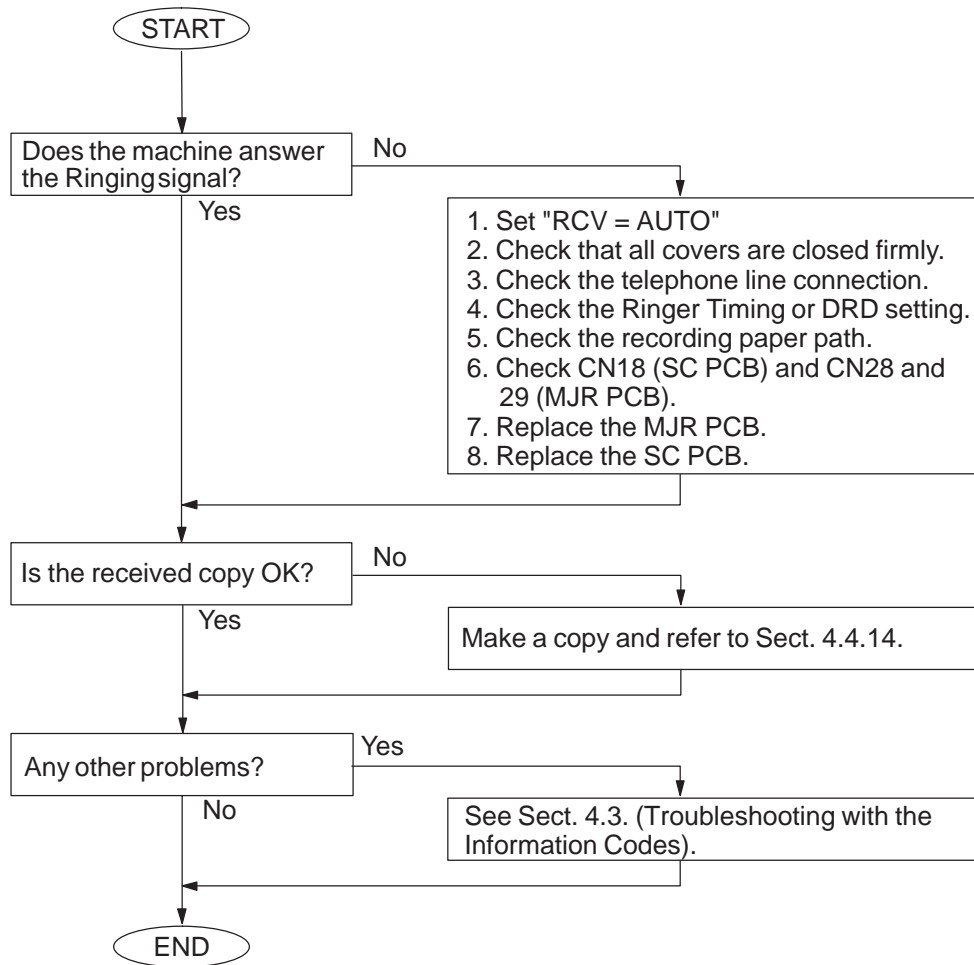

### 4.6.6. Polling Problems

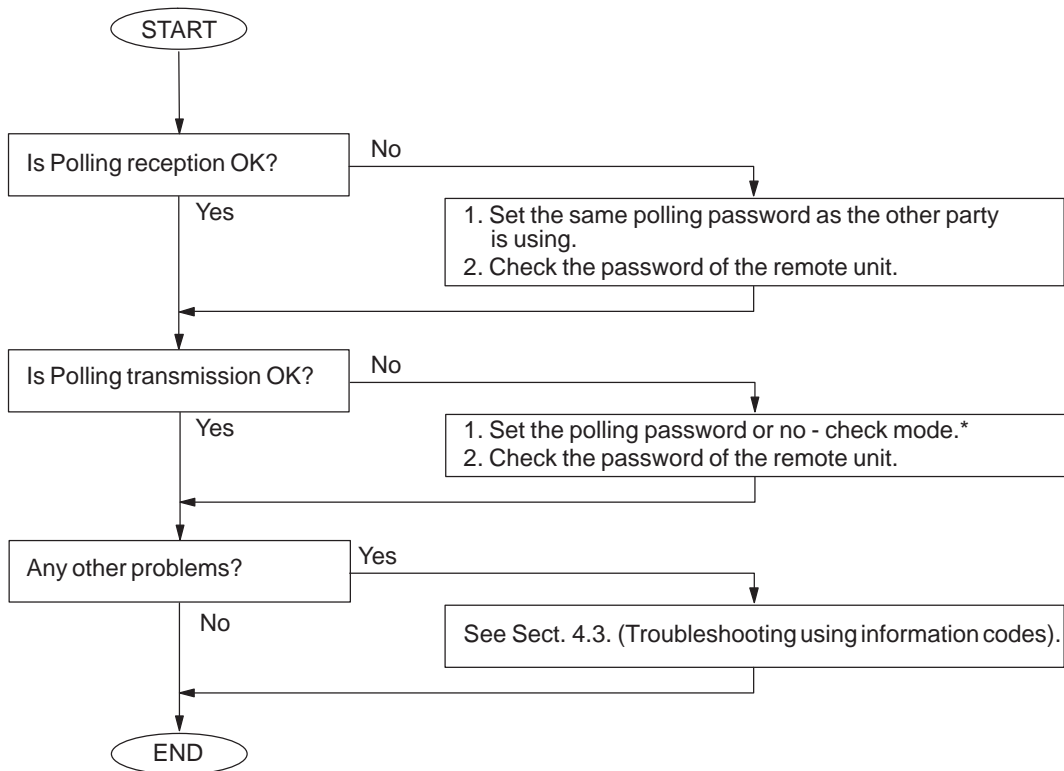

**Note:**  
No-check Mode means that password is not set.

#### 4.7. Information Codes Table (For Facsimile)

Fax Information Codes				
Code	Mode	Phase	Description of Problem	Cause
001	RCV COPY	C, D	Leading edge of the recording paper fails to reach the Timing Sensor. (1st Cassette)	Recording paper jam. Timing Sensor abnormal.
002	RCV COPY	C, D	Leading edge of the recording paper fails to reach the Timing Sensor. (2nd Cassette)	Recording paper jam. Timing Sensor abnormal.
007	RCV COPY	C, D	1. Leading edge of the recording paper fails to reach the Paper Exit Sensor. 2. Recording paper has not completely passed the Paper Exit Sensor.	Recording paper jam. Paper Exit Sensor abnormal.
010	RCV COPY	B, C	No recording paper.	No recording paper or paper is not set properly. No Paper Sensor is defective.
011	STANDBY	B, C	Paper Cassette is not installed properly.	
012	RCV	C, D	The length of the received document is over 2 meter (78.7in).	
021	STANDBY RCV COPY	B, C, D	Thermistor is abnormal. Fuser Control is abnormal. Fan is abnormal.	Defective SC PCB. Defective Fuser Unit, Power Supply Unit. Defective Fan.
030	XMT	B	Read Point Sensor does not go ON within 10 seconds after the document starts feeding.	Document is not set properly. Defective Read Point Sensor.
031	XMT COPY	C	Transmitting document was longer than 2 meter (or 78.7 in).	The document may jam. Defective Read Point Sensor.
041	STANDBY RCV COPY	B, C, D	Out of toner.	No toner. Defective Toner Sensor.
043	STANDBY RCV COPY	B, C, D	Low toner.	Toner is getting low. Defective Toner Sensor.
045	STANDBY	-	No Toner Cartridge.	Toner cartridge has not been installed. Defective Toner Sensor (Cartridge Sensor).
051	RCV COPY	-	Printer Motor abnormal.	Connector not properly connected. Defective Printer Motor. Defective SC PCB.
054	STANDBY RCV COPY	-	HSYNC abnormal. Motor abnormal.	Defective Laser Unit.
060	-	A	Printer Cover is open.	Cover is not firmly closed. Connectors are not firmly connected.
061	-	A	ADF Door is open.	Door is not firmly closed. Connectors are not firmly connected.

Fax Information Codes				
Code	Mode	Phase	Description of Problem	Cause
200	RCV	C	Decoding process is not completed at the end of phase C.	Defective SC PCB.
212	XMT RCV	A-E	Interface error occurred between the CPU and modem.	Modem is defective. (SC PCB) Software problem occurred. (SC PCB)
301	XMT RCV	-	System fault.	Software problem occurred. (SC PCB)
331	XMT	C	8-minutes timer error. (Germany only)	
390	STANDBY RCV PRINT	-	Interface error occurred between the machine and the PC.	Firmware update error. GDI print error. (Perform the operation again)
400	XMT	B	T1 timer (35±5 sec.) elapsed without detecting 300 bps signal.	Wrong number is dialed and the START button is pushed. Telephone line is disconnected while dialing. SC PCB (Modem) or MJR PCB are defective. Receiver is defective. (It may only be transmitting CED)
401	XMT	B	DCN was returned from receiver while transmitter is waiting for CFR or FTT.	Your machine's ID Number is not programmed. Possible incompatibility or incorrect Password.
402	XMT	B	DCN was returned from receiver while transmitter is waiting for NSF/DIS.	Receiver working in non-CCITT mode only. (Possible incompatibility)
403	RCV (Polling)	B	Transmitter had no polling function.	"POLLED=ON" (polling XMT ready) is not set at the transmitter. Document to be transmitted is not placed at the transmitter.
404	XMT	B	Transmitter sent NSS (or DCS) followed by TCF three times, but the receiver did not respond. (CFR or FTT is usually returned)	Receiver is defective. (Modem, MJR PCB, etc.) SC PCB or MJR PCB are defective. Receiver disconnects line during first NSS (or DCS) is transmitted.
405	XMT	B	Transmitter received FTT after it transmitted TCF at 2400bps. Received RTN after communicating at 2400 bps.	Line quality is poor. (TCF is damaged due to line noise) Receiver is defective. (Modem, etc.) SC PCB or MJR PCB are defective.
406	RCV (Password Comm.)	B	XMT-Password mismatched. RCV-Password mismatched. Selective RCV incomplete.	XMT, RCV password does not match. Last 4 digits of TSI does not match with the last 4 digits of ONE-TOUCH, ABBR telephone number.
407	XMT	D	Transmitter received no response after it transmitted post message, such as EOP, MPS, EOM, etc...or received DCN.	Receiver is defective. (No paper, paper jamming, etc.) Receiver ceased receiving because of excessive error. (Line quality is poor) SC PCB (Modem) or MJR PCB are defective.

<b>Fax Information Codes</b>				
<b>Code</b>	<b>Mode</b>	<b>Phase</b>	<b>Description of Problem</b>	<b>Cause</b>
408	XMT	D	Transmitter received RTN after it transmitted EOP, MPS, or EOM.	Receiver receives data with error. (Line quality is poor) Receiver is defective. (Modem, etc.) SC PCB or MJR PCB are defective.
409	XMT	D	Transmitter receives PIN after it transmitted a post message, such as EOP, MPS, EOM, etc.	Receiver receives data with error due to poor line quality, and receiving operator requests voice contact. Receiver is defective. (Modem, etc.) SC PCB or MJR PCB are defective.
410	RCV	D	Received DCN while waiting for post command. (EOP, MPS, EOM, etc.)	Interface or line is faulty. Transmitter is defective.
411	RCV (Polling)	B	Received DCN after transmitting NSC.	Transmitter is not ready for polling communication. Password does not match between transmitter and receiver.
412	G3 RX	B, D	No response within 12 seconds in NSS/DCS/MPS wait state. (After transmitting FTT)	Transmitter is defective. SC PCB is defective.
414	RCV (Polling)	B	No response received after transmitting 3rd NSC.	Password does not match between transmitter and receiver. Transmitter is defective. (No original, document jam, etc.)
415	XMT (Polling)	B	Remote side attempted to receive message from your machine in polling communication.	Inform the remote side that your machine does not have the polling transmission feature.
416	RCV	D	Receiver did not detect post command, such as EOP, MPS, EOM, etc.	Transmitter is defective. Line quality is poor. (RTC signal is distorted due to line noise) SC PCB or MJR PCB are defective.
417	RCV	C	Receiver returned RTN in response to post message.	Line quality is poor. (There are excessive errors in received data) SC PCB or MJR PCB are defective.
418	RCV	C	Receiver transmitted PIN in response to PRI-Q from transmitter. (Transmitting operator requests voice contact)	Line quality is poor. (There are excessive errors in received data) SC PCB or MJR PCB are defective.
420	RCV	B	T1 timer (35 sec.) elapsed without detecting 300 bps signal.	There is wrong incoming call.(non-facsimile communication) Transmitter is defective. SC PCB or MJR PCB are defective.
421	RCV	B	Busy Tone is detected after sending NSF Signal.	Remote station disconnected the line. Wrong number is dialed.
422	XMT	B	Content of NSF (or DIS) or NSC (or DTC) was invalid.	There is an incompatibility.
427	G3 RCV	B	DCN received to NSF/CSI/DIS transmitted.	The interface is incompatible.
433	XMT RCV	B, D	T.30 Protocol abnormal.	Defective remote station.



Fax Information Codes				
Code	Mode	Phase	Description of Problem	Cause
434	XMT or RCV	B	CD (response from Modem) did not turn OFF within 180 sec. after receiver detected FLAG signal.	Remote unit is defective. SC PCB or MJR PCB are defective.
436	G3 RX	C	DCN received after transmitting FTT.	Transmitter is defective or incompatible. Line quality is poor.
456	RCV	B	Received relay transfer request or confidential document to distribute to an end receiving station or all confidential mailboxes are used.	
459	RCV	C	Failed training in Phase C.	Line quality is poor. (Training signal is distorted due to line noise) SC PCB or MJR PCB are defective.
490	RCV	C	Sum of error lines exceeded the limit (Function Parameter No. 70) of 64 lines.	Line quality is poor. SC PCB or MJR PCB are defective.
494	RCV	C	Interval between two EOLs was more than 10 sec. when receiver received message data.	Transmitter is defective. Line quality is poor. (EOL is damaged due to line noise) SC PCB or MJR PCB are defective.
495	XMT RCV	C	During reception, CD turned OFF or continued ON for long time. During communication, lost loop - current.	Line is disconnected. Transmitter is defective. SC PCB or MJR PCB are defective.
496	XMT	C	CS of modem is not able to turn ON.	SC PCB is defective.
501	XMT/ RCV(V.34)	B	Remote unit does not have compatible Modem.	
502	XMT/ RCV(V.34)	B, C, D	During reception, CD turned OFF or continued ON for long time. During communication, lost loop - current.	Line is disconnected. Transmitter is defective. SC PCB or MJR PCB are defective.
503	XMT/ RCV(V.34)	B, C, D	CS of modem is not able to turn ON during training.	SC PCB is defective. Line is disconnected.
504	XMT/V.34 (Polling)	B	Polling is rejected from the remote station.	No polling original is set.
505	XMT/V.34 (Polling)	B	Polling XMT is rejected.	No polling original is set.
540	XMT ECM	B	No response after transmitting 3rd CTC or DCN received.	Incompatible interface.
541	XMT ECM	D	No response after transmitting 3rd EOR or received DCN.	Line is faulty. MJR PCB abnormal.
542	XMT ECM	D	No response to the 3rd RR transmitted or received DCN.	Remote unit is abnormal.
543	XMT ECM	D	T5 timer (60 sec.) elapsed without MCF.	Remote unit is abnormal.
544	XMT ECM	D	Stopped Transmission after EOR Transmission.	Line is faulty. MJR PCB abnormal.
550	RCV ECM	C	Timer between frames in phase C has elapsed.	Defective remote station.
554	RCV ECM	D	Transmitted ERR after receiving EOR.	Line is faulty.

Fax Information Codes				
Code	Mode	Phase	Description of Problem	Cause
555	RCV ECM	D	Transmitted PIN after receiving EOR.	Line is faulty and Operator Call requested by RX side.
570	RCV	B	Password or machine code did not match during remote diagnostic communication.	
571	XMT	B	Remote unit did not have the remote diagnostic function.	
580	XMT	B	Sub-address transmission to a unit that has their DIS bit 49 (NSF bit 155) OFF.	Sub-address transmission to a unit that has no Sub-address function.
581	XMT	B	Sub-address Password transmission to a unit that has their DIS bit 50 (NSF bit 156) OFF.	Sub-address transmission to a unit that has no Sub-address function.
601	XMT		ADF Door was opened during ADF transmission.	
623	XMT	A	No original was in the ADF. (Built-in dialer engaged)	Operator removed the original from the ADF after dialing was completed. Original was not set properly in the ADF.
630	XMT or RCV (Polling)	B	Redial count over.	No dial tone detected. Sensor dial tone is not detected. (destination dependent) Busy tone is detected. (destination dependent) T1 timer (35±5 sec.) elapsed without a signal from the receiver.
631	XMT	A	"STOP" button was pressed during Auto Dialing.	
634	XMT	B	Redial count over with no response or busy tone was not detected. <b>Note:</b> U.S.A. and Canadian models will redial only once if a busy tone is not detected.	Telephone line cable is disconnected. Wrong number is dialed. SC or MJR PCB is abnormal.
638	XMT		Power turned off with applicable data in memory or during communication.	Power cord unplugged. Power failure occurred.
800	Relay Comm.		The machine was requested to relay a document but has no Relay Hub capability.	
815			Mailbox is full.	
816	Conf. Polled		"The received Polling Password did not match. The machine does not have Confidential Comm. capability."	
825	Conf. RCV Conf. Polled		Parameter settings of the initial sending station are not properly set.	
870	MEM XMT Multi-Copy		Memory overflow occurred while storing documents into memory.	
880	-	-	File Access Error.	
884	-	-	File Access Error.	

## 4.8. Diagnostic Codes (For Facsimile)

The 13-digit Diagnostic Code is provided for the service engineer to analyze how the communication was performed. The code is recorded on the Journal.

### Journal Example

***** -JOURNAL- ***** DATE MMM-dd-yyyy ***** TIME 09:39*****									
NO.	COMM.	PAGES	FILE	DURATION	X/R	IDENTIFICATION	DATE	TIME	DIAGNOSTIC
01	OK	001	129	00:00'42	XMT	123 456 789	NOV-12	01:55	C8649003C0000
									<div style="display: flex; justify-content: space-around; align-items: center;"> <span>↑ 1st digit</span> <span>↑ 13th digit</span> </div>
-----									
- PANASONIC PANAFAX									
***** - PANAFAX - ***** -12345678901234567890- *****									

### 1st Digit: Manufacturer Code

-: Not used/defined

Fax Diagnostic Codes				
Data	Definition			
	Manufacturer Code			
0	-			
1	Casio			
2	Canon			
3	Sanyo			
4	Sharp			
5	Tamura			
6	Toshiba			
7	NEC			
8	Oki			
9	Hitachi			
A	Xerox			
B	Fujitsu			
C	Matsushita			
D	Mitsubishi			
E	Murata			
F	Ricoh			

**2nd Digit**

-: Not used/defined

Fax Diagnostic Codes				
Data	Definition			
	ID (TSI, CSI, CIG)	RTN	DCN	STOP Button
0	-	-	-	-
1	Received	-	-	-
2	-	Received	-	-
3	Received	Received	-	-
4	-	-	Received	-
5	Received	-	Received	-
6	-	Received	Received	-
7	Received	Received	Received	-
8	-	-	-	Pressed
9	Received	-	-	Pressed
A	-	Received	-	Pressed
B	Received	Received	-	Pressed
C	-	-	Received	Pressed
D	Received	-	Received	Pressed
E	-	Received	Received	Pressed
F	Received	Received	Received	Pressed

**3rd Digit**

-: Not used/defined

Fax Diagnostic Codes				
Data	Definition			
	Resolution (dpi)	Paper Width		
0	-	A4		
1	S-Fine	A4		
2	400 x 400	A4		
3	300 x 300	A4		
4	-	-		
5	-	-		
6	-	-		
7	-	-		
8	-	-		
9	-	-		
A	-	-		
B	-	-		
C	-	-		
D	-	-		
E	-	-		
F	-	-		

**4th Digit**

-: Not used/defined

Fax Diagnostic Codes				
Data	Definition			
	Scanning Rate	Resolution		
0	20 ms/line	Std		
1	5 ms/line	Std		
2	10 ms/line	Std		
3	-	Std		
4	40 ms/line	Std		
5	-	Std		
6	-	Std		
7	0 ms/line	Std		
8	20 ms/line	Fine		
9	5 ms/line	Fine		
A	10 ms/line	Fine		
B	-	Fine		
C	40 ms/line	Fine		
D	-	Fine		
E	-	Fine		
F	0 ms/line	Fine		

**5th Digit**

-: Not used/defined

Fax Diagnostic Codes				
Data	Definition			
	Deferred Comm.	Dialing/RCV	Memory/ Non-Memory	
0	-	Manual Communication	Non-Memory	
1	Used	Manual Communication	Non-Memory	
2	-	Auto Dialing	Non-Memory	
3	Used	Auto Dialing	Non-Memory	
4	-	Auto RCV	Non-Memory	
5	Used	Auto RCV	Non-Memory	
6	-	Remote RCV	Non-Memory	
7	Used	Remote RCV	Non-Memory	
8	-	Manual Communication	Memory	
9	Used	Manual Communication	Memory	
A	-	Auto Dialing	Memory	
B	Used	Auto Dialing	Memory	
C	-	Auto RCV	Memory	
D	Used	Auto RCV	Memory	
E	-	Remote RCV	Memory	
F	Used	Remote RCV	Memory	

**6th Digit**

-: Not used/defined

<b>Fax Diagnostic Codes</b>				
<b>Data</b>	<b>Definition</b>			
	<b>Polling</b>	<b>XMT/RCV</b>	<b>Selective Comm.</b>	<b>Password Comm.</b>
0	-	RCV	Off	Off
1	Yes	RCV	Off	Off
2	-	XMT	Off	Off
3	Yes	XMT	Off	Off
4	-	RCV	On	Off
5	Yes	RCV	On	Off
6	-	XMT	On	Off
7	Yes	XMT	On	Off
8	-	RCV	Off	On
9	Yes	RCV	Off	On
A	-	XMT	Off	On
B	Yes	XMT	Off	On
C	-	RCV	On	On
D	Yes	RCV	On	On
E	-	XMT	On	On
F	Yes	XMT	On	On

**7th Digit**

-: Not used/defined

<b>Fax Diagnostic Codes</b>				
<b>Data</b>	<b>Definition</b>			
	<b>Sub-Address Comm.</b>	<b>Confidential Comm.</b>	<b>Relayed Comm.</b>	<b>Turnaround Polling</b>
0	-	-	-	-
1	Yes	-	-	-
2	-	Yes	-	-
3	Yes	Yes	-	-
4	-	-	Yes	-
5	Yes	-	Yes	-
6	-	Yes	Yes	-
7	Yes	Yes	Yes	-
8	-	-	-	Yes
9	Yes	-	-	Yes
A	-	Yes	-	Yes
B	Yes	Yes	-	Yes
C	-	-	Yes	Yes
D	Yes	-	Yes	Yes
E	-	Yes	Yes	Yes
F	Yes	Yes	Yes	Yes

**8th Digit**

-: Not used/defined

Fax Diagnostic Codes				
Data	Definition			
	Advanced Comm.	Cover Sheet XMT		
0	-	-		
1	Report XMT	-		
2	Check & Call	-		
3	-	-		
4	Memory Transfer	-		
5	-	-		
6	-	-		
7	-	-		
8	-	Yes		
9	Report XMT	Yes		
A	Check & Call	Yes		
B	-	Yes		
C	Memory Transfer	Yes		
D	-	Yes		
E	-	Yes		
F	-	Yes		

**9th Digit**

-: Not used/defined

Fax Diagnostic Codes				
Data	Definition			
	Short Protocol	Standard/ Non-Standard		
0	-	Standard		
1	-	Standard		
2	-	Standard		
3	-	Standard		
4	-	Standard		
5	-	Standard		
6	-	Standard		
7	-	Standard		
8	-	Non-Standard		
9	B	Non-Standard		
A	-	Non-Standard		
B	D	Non-Standard		
C	-	Non-Standard		
D	-	Non-Standard		
E	-	Non-Standard		
F	-	Non-Standard		

**10th Digit**

-: Not used/defined

Fax Diagnostic Codes				
Data	Definition			
	Coding	ECM		
0	MH	-		
1	MR	-		
2	MMR	-		
3	-	-		
4	-	-		
5	-	-		
6	-	-		
7	-	-		
8	MH	Yes		
9	MR	Yes		
A	MMR	Yes		
B	-	-		
C	-	-		
D	-	-		
E	-	-		
F	-	-		

**11th Digit**

-: Not used/defined

Fax Diagnostic Codes				
Data	Definition			
	Symbol Rate (V.34)	V.34		
0	-	-		
1	-	-		
2	-	-		
3	-	-		
4	-	-		
5	-	-		
6	-	-		
7	-	-		
8	2400 sr	Yes		
9	-	-		
A	2800 sr	Yes		
B	3000 sr	Yes		
C	3200 sr	Yes		
D	3429 sr	Yes		
E	-	-		
F	-	-		



**12th Digit**

-: Not used/defined

Fax Diagnostic Codes				
Data	Definition			
	Modem Speed	Modem Speed (V.34)		
0	2400 bps	-		
1	4800 bps	2400 bps		
2	7200 bps	4800 bps		
3	9600 bps	7200 bps		
4	TC 7200 bps	9600 bps		
5	TC 9600 bps	12000 bps		
6	12000 bps	14400 bps		
7	14400 bps	16800 bps		
8	-	19200 bps		
9	-	21600 bps		
A	-	24000 bps		
B	-	26400 bps		
C	-	28800 bps		
D	-	31200 bps		
E	-	33600 bps		
F	-	-		

**13th Digit**

-: Not used/defined

Fax Diagnostic Codes				
Data	Definition			
	Line Status			
0	-			
1	Private Line			
2	-			
3	-			
4	-			
5	-			
6	-			
7	-			
8	-			
9	-			
A	-			
B	-			
C	-			
D	-			
E	-			
F	-			

## 5 Service Modes

### 5.1. Service Modes (For Facsimile)

#### 5.1.1. Service Mode Table

The following service modes are provided to assist you in setting operational functions of the unit and determining the condition of the unit.

**Caution:**

The factory default parameters are preset (destination dependent) for optimum performance and in compliance with the local telecommunication regulations/standards, and do not need to be changed. Changing some of these parameters may cause the unit to be no longer compliant or become inoperable.

No.	Service Mode	Description
1	Function Parameter Setting	Allows changes to the function parameters (the home position, etc.).
2	RAM Edit Mode	Factory use only.
3	Print Parameter List / Reports	Prints the Function Parameter List, Page Memory Test, Printer Report, All Document File, Protocol Trace, Toner Order Form and Drum Unit Order Form.
4	Modem Tests	Generates various binary, tonal and DTMF signals, by the modem.
5	Diagnostic	Performs various hardware tests.
6	RAM Initialization	Initialize RAM and restore the default value of the function parameters.
7	LBP Service Mode	Changes the Printer Parameters.
8	Check & Call	Allows input of information for Service Alert Report, Maintenance Alert Report, Toner Order Form and Drum Unit Order Form.
9	System Maintenance	Used for Firmware Update and Sending a Received File during a fatal printer error.

### 5.1.2. Service Mode 1 (Function Parameter Setting)

Use the following procedure to change the function parameters.

Service Mode 1		
Step	Operation or Unit Condition	LCD Display
1	Standby	MMM-dd-yyyy 15:00 00%
2	Press "FUNCTION" and then "7".	SET MODE (1-6) ENTER NO. OR V ^
3	Press "MONITOR" four times, then press "*".	SERVICE MODE ENTER NO. OR V ^
4	Press "1".	PARAMETER (000-199) ENTER PARAMETER #_
5	Enter the Function Parameter Number. Ex: Changing the "ALARM STATUS" -- Enter "001" and press [SET].	PARAMETER #001 ALARM STATUS?
6	Press "START".	ALARM STATUS:Timer 1:OFF 2:Tmr 3:CONST
7	Enter the new setting value. Ex: Enter "3" for Constant.	ALARM STATUS:Const. 1:OFF 2:Tmr 3:CONST
8	Press "START". The new value will be stored and the next parameter will be displayed.	PARAMETER #002 STOP COMM.JRNL?
9	Repeat steps 4 through 7 to change other Function Parameters or Press "STOP" twice to return to standby.	MMM-dd-yyyy 15:00 00%

**Note:**

The following buttons provide these functions in the Service Mode:

- "START" : The new setting value is stored in the machine.
- "V" : Scroll the function parameter number down.
- "^" : Scroll the function parameter number up.

**Function Parameter Table**

No.	Parameter	Selections	Function
000	MON/TEL DIAL	1 = Monitor 2 = TEL/DIAL	Selects whether the machine starts to TX automatically during On-Hook dialing. <b>Monitor</b> : Start to TX after pressing START <b>TEL/DIAL</b> : Start to TX automatically
001	ALARM STATUS	1 = OFF 2 = Timer (6 sec.) 3 = Constant	Selects the No Paper or No Toner alarm status. <b>OFF</b> : Alarm is disabled. <b>Timer</b> : Alarm will shut off after 6 seconds. <b>Constant</b> : Alarm will not stop until "STOP" is pressed or the error is cleared/corrected.
002	STOP COMM. JRNL	1 = Off 2 = On	Selects whether the machine prompts to print the COMM. Journal when the printout condition is set to INC and STOP is pressed during communication.
003	CONTINUOUS POLL	1 = Off 2 = Stn (Tx only)	Selects whether the Continuous Polling feature is enabled. <b>Stn:</b> Place the document(s) on the ADF then press the Program Key [P4] to store or add the document(s) into a polled file. (See Note 4)
004	NUMERIC ID SET	1 = Off (will not accept) 2 = On (accepts)	Selects whether the machine accepts and allows to set or change the Numeric ID.
005	Not Used		
006	ID DISPLAY	1 = Number (Numeric ID) 2 = Chara (Character ID)	Selects the priority of displaying the ID.
007	JNL COLUMN	1 = Preset station name 2 = Received ID	Selects the contents of the ID to display on the Journal.
008	MONITOR	1 = Off 2 = On	Selects whether the Monitor is ON/OFF for monitoring fax signals. <b>(FOR SERVICE USE ONLY)</b>
009	DC LOOP	1 = Off (Normal) 2 = On (Off Hook)	Selects a false Off Hook state for back to back communication test.
010	TX LEVEL	00 = 0 dBm ~ 15 = -15 dBm	Selects the TX signal output level, 0 to -15 dBm in 1 dBm steps. (Refer to Chapter 4.3.)
011	RX LEVEL	1 = -43 dBm 2 = -38 dBm 3 = -33 dBm 4 = -48 dBm	Selects the receiving sensitivity of -33/-38/-43/-48 dBm.
012	DTMF LEVEL	00 = 0 dBm ~ 15 = -15 dBm	Selects the DTMF output level, 0 to -15 dBm in 1 dBm steps.
013	G3 RX EQL	1 = 0 dB 2 = 4 dB 3 = 8 dB 4 = 12 dB	Selects the cable equalizer for G3 reception mode, 0dB, 4dB, 8dB or 12dB.
014	G3 TX EQL	1 = 0 dB 2 = 4 dB 3 = 8 dB 4 = 12 dB	Selects the cable equalizer for G3 transmission mode, 0dB, 4dB, 8dB or 12dB.

Function Parameter Table			
No.	Parameter	Selections	Function
015 ~ 016	Not Used		
017	TX START	1 = 2400 bps 2 = 4800 bps 3 = 7200 bps 4 = 9600 bps 5 = TC7200 bps 6 = TC9600 bps 7 = 12000 bps 8 = 14400 bps	Selects the transmission modem start speed, 14400/12000/TC9600/TC7200/9600/7200/4800/2400 bps. <b>Note:</b> This parameter is applicable only when communicating with regular G3 machines. When communicating with Super G3 (V.34) machines, use Parameter No. 32.
018	RX START	1 = 2400 bps 2 = 4800 bps 3 = 7200 bps 4 = 9600 bps 5 = TC7200 bps 6 = TC9600 bps 7 = 12000 bps 8 = 14400 bps	Selects the reception modem start speed, 14400/12000/TC9600/TC7200/9600/7200/4800/2400 bps. <b>Note:</b> This parameter is applicable only when communicating with regular G3 machines. When communicating with Super G3 (V.34) machines, use Parameter No. 33.
019	ITU-T V.34	1 = Off 2 = On 3 = Select	Selects whether the ITU-T V.34 is Off, On or Select. <b>Select:</b> Select whether the ITU-T V.34 is Off or On, when entering Phone Book Dialing Numbers or Manual Number Dialing.
020	ITU-T ECM	1 = Off (Invalid) 2 = On (Valid)	Select the ECM mode.
021	EP TONE	1 = Off (without EP Tone) 2 = On (with EP Tone)	Selects whether to add the echo protect tone on V.29 mode. (Used when Echo Suppression is disabled.) <b>On</b> : Add <b>Off</b> : Do not add
022	SIGNAL INTERVAL	1 = 100 ms 2 = 200 ms 3 = 500 ms	Selects the time interval between the receiving signal and the transmitting signal.
023	TCF CHECK	1 = Normal (Short) 2 = Long	Selects the TCF check interval Long/Short
024	CED FREQUENCY	1 = 1080 Hz (non ITU-T) 2 = 2100 Hz	Selects the CED frequency 2100/1080 Hz
025	COMM. START-UP	1 = 1'st response 2 = 2'nd response	Selects the communication start-up condition (XMT and Polling). (Used when Echo Suppression is disabled.)
026	NON-STANDARD	1 = Off (Invalid) 2 = On (Valid)	Selects own mode (Panafax mode).
027	SHORT PROTOCOL B	1 = Off (Invalid) 2 = On (Valid)	Selects the short protocol mode.
028	SHORT PROTOCOL D	1 = Off (Invalid) 2 = On (Valid)	Selects the short protocol mode. When activated, it allows the machine to automatically store the modem speed for each Auto Dial Number.
029	REMOTE DIAGNOSTICS	1 = Off (will not accept) 2 = On (accepts)	Selects whether the machine accepts Remote Diagnostics from the service station.

Function Parameter Table			
No.	Parameter	Selections	Function
030	CED & 300 bps	1 = 75 ms 2 = 1 sec	Selects the pause interval between the CED and the 300 bps signal. (Used when Echo Suppression is disabled.)
031	RTC = EOLx12	1 = Off (EOLx6) 2 = On (EOLx12)	Selects the RTC signal, EOLx6 or EOLx12.
032	V34 TX START	2400-33600bps	Selects the transmission modem start speed for V.34 communication, 33600-2400 bps.
033	V34 RX START	2400-33600bps	Selects the receiving modem start speed for V.34 communication, 33600-2400 bps.
034	V34 TX Symbol Rate	2400-3429sr	Selects the transmission symbol rate for V.34, 3429/3200/3000/2800/2400 sr. Press "V" or "^" to select the symbol rate.
035	V34 RX Symbol Rate	2400-3429sr	Selects receiving symbol rate for V.34, 3429/3429/3200/3000/2800/2400 sr. Press "V" or "^" to select the symbol rate.
036	Not Used		
037	PROTOCOL DISPLAY	1 = Off (not displayed) 2 = On (displayed)	Selects whether to display the modem speed during communication. Press "V" or "^" to display.
038	Not Used		
039	FLASH TIME	5 = 50 ms ~ 100 = 1000 ms	Selects the pause interval before activating the Flash key.
040	E/F TIME (Except for USA and Canada)	5 = 50 ms ~ 100 = 1000 ms	Selects the pause interval before activating the Flash key.
041	PAUSE TIME	1 = 1 sec. ~ 10 = 10 sec.	Selects the pause interval from 1 sec. ~ 10 sec. for dialing through a switchboard or for international calls.
042	Not Used		
043	REDIAL INTERVAL	0 = no waiting ~ 15 = 15 minutes	Selects the redial interval from 0 to 15 minutes in 1 minute steps.
044	REDIAL COUNT	0 = no redial ~ 15 = 15 times	Selects the redial count from 0 to 15 times in 1 step intervals. <b>Note:</b> In order to comply with the requirements TBR21 in the EC destinations, do not select 15 times.
045	RING DETECT COUNT	1 = 1 ring ~ 9 = 9 rings	Selects the ring detection count from 1 to 9 rings in 1 ring step intervals.
046	ON-HOOK TIME	0 = 0 sec. ~ 90 = 90 sec.	Selects the on-hook time between sequential communication calls in 1 second step intervals.
047	RESPONSE WAIT	1 = 1 sec. ~ 90 = 90 sec.	Selects the waiting interval for the response after completing the dialing.
048	Not Used		
049			

Function Parameter Table			
No.	Parameter	Selections	Function
050	RING DETECT MODE	1 = Normal 2 = Rough	Selects the quality of ringer detection. Use if the line signal is out of regulation, set to "Rough" so that the unit may detect the ringing signals.
051	Not Used		
052	PULSE RATE	1 = 10 pps 2 = 20 pps	Selects the dial pulse rate 10/20 pps.
053 054	Not Used		
055	BUSY TONE CHECK	1 = Off 2 = On	Selects whether to detect the Busy Tone.
056	DIAL TONE CHECK (Except for USA and Canada)	1 = Off 2 = On	Selects whether to detect dial tone before dialing the telephone number.
057	DC LOOP CHECK (Except for USA and Canada)	1 = Off (will not check) 2 = On (checks)	Selects whether the unit checks the DC Loop during communication.
058	COMM.JRNL +IMAGE	1 = Off (without image) 2 = On (with image)	Selects whether the machine prints the COMM. Journal with image.
059	CONF. RCV REPORT ON	1 = Off 2 = On	
060	VERSION	Indicates the Host software version.	
061	TX/RX/PRT/CPY COUNTER	TX/RX/PRT/CPY	Displays the transmitted, received, total printed and copied document count.
062	PRINT COUNTER	1 = Off 2 = On	Selects whether to print in the Fax Parameter List, the counter information that is displayed in the Function Parameter No. 61.
063	Not Used		
064	SILENT DETECTION TIME OUT	01 = 1 sec. ~ 60 = 60 sec.	Select silent detection timeout time (TAM I/F).
065	SILENT INTEGRATION TIME	01 = 1 sec. ~ 10 = 10 sec.	Select ring detection integration time (TAM I/F).
066	RING COUNT (TAM)	01 = 1 sec. ~ 99 = 99 sec.	Select ring detection count 1 to 99 times in one step intervals on TAM I/F mode.
067	Not Used		
068	NYSE FAX FORWARD (For USA and Canada only)	1 = Off 2 = On	Selects whether the machine will forward the incoming and outgoing faxes to a specified station.  <b>Note:</b> Once this parameter is activated, Fax Forwarding via Fax Parameter 054 is automatically disabled.
069	NYSE LOCAL PRINT (For USA and Canada only)	1 = INC 2 = ON (Always)	Selects the printing condition for the incoming faxes after FAX Forwarding. <b>INC.</b> : Prints only if FAX Forwarding fails. <b>ON</b> : Always prints.

Function Parameter Table			
No.	Parameter	Selections	Function
070	LINE ERROR	1 = 128 lines 2 = 256 lines 3 = 512 lines 4 = 1024 lines 5 = 2048 lines 6 = Off (will not disconnect line)	1. Selects the line disconnect condition during reception. If the number of line errors exceed this setting, the unit will disconnect the line. 2. Selects the transmit condition of RTP/PIP or RTN/PIN. (Available if No.73 Error Detect is set to "LINES") (See Note 1)
071	TOTAL ERROR	1 = 5% 2 = 10% 3 = 15% 4 = 20%	Selects the transmit condition of RTP/PIP or RTN/PIN. (Available if No.73 Error Detect is set to "RATE".) (See Note 2)
072	CONTINUOUS ERROR	1 = Off (unlimited) 2 = 3 lines/STD 3 = 6 lines/STD 4 = 12 lines/STD	Selects the continuous total error criteria of Off/3/6 or 12 lines in Standard mode. If continuous total error exceeds this setting, the unit will transmit RTN/PIN. (Available if No.73 Error Detect is set to "RATE".)
073	ERROR DETECT	1 = Lines 2 = Rate	Selects the error detect condition Lines/Rate.
074	RTN RECEIVE	1 = Disconnect 2 = Continue	Selects whether to disconnect the phone line or continue when "RTN" is received.
075	CODING	1 = MH (MH only) 2 = MR (MH or MR) 3 = MMR (MH or MR or MMR)	Selects the coding scheme.
076	Not Used		
077	RX JAM LENGTH	1 = Off (unlimited) 2 = 2 m 3 = 8 m	Selects the maximum length of a received document that can be printed.
078 079	Not Used		
080	DOC. TOP FEED	-5.0 mm ~ +5.0 mm	Adjusts the distance between the scanning sensor ON position and the scanning start position.
081	DOC. END FEED	-5.0 mm ~ +5.0 mm	Adjusts the distance between the scanning sensor OFF position and the scanning end position.
082	JAM LENGTH	1 = 1 m 2 = 2 m 3 = 8 m 4 = Unlimited	Selects the maximum length of the original that can be scanned.
083	Not Used		
084	LINE AS NO PAPER	1 = Ring (ring) 2 = Busy (keep line busy)	Selects whether to ring or send a busy tone to the remote station when the recording paper runs out or the unit cannot receive because of any trouble.
085	Not Used		
086	REDUCTION FINE	1 = Off 2 = On	Selects whether the resolution is preset to Fine, when sending with reduction B4→A4. (For B4 Scanning Model only)
087	DARKER LEVEL	0 = Lightest Contrast	Selects the contrast level. 0← →15 Lightest← →Darkest
088	NORMAL LEVEL	~	
089	LIGHTER LEVEL	15 = Darkest Contrast	



Function Parameter Table			
No.	Parameter	Selections	Function
090	PRINT DENSITY	1 = Normal 2 = Darker	Print Density sometimes gets light at low Humidity condition. In this case, selects "2:Darker". (Except for U.S.A. and Canada)
091	Not Used		
092	SMOOTHING	1 = Off 2 = On	Selects whether the smoothing function is available.
093 ~ 129	Not Used		
130	BUSY-ACK TIMING (Except UF-580/ 780)	<ul style="list-style-type: none"> <li>• In Busy</li> <li>• After Busy</li> <li>• While Busy</li> </ul>	Selects the signal timing between the BUSY and ACK signal in Printer Interface Mode.
131	CMD RCV GRD TIMER (Except UF-580/ 780)	1 min. ~ 15 min.	Selects the Guard Timer between each GDI Command in Printer Interface Mode.
132	PRT DATA TIMER (Except UF-580/ 780)	1 min. ~ 15 min.	Selects the Guard Timer between each GDI Data Frame in Printer Interface Mode.
133	COLLATION (PRT) (Except UF-580/ 780)	1 = Off 2 = On 3 = Auto	Selects the Print Collation in Printer Interface Mode. When "Auto" is selected, print collation will operate according to the setting in Fax Parameter #65.
134	COLLATION (PC I/F) (Except UF-580/ 780)	1 = Off 2 = On 3 = Auto	Selects the Print Collation in PC Interface Mode. When "Auto" is selected, print collation will operate according to the setting in Fax Parameter #65.
135 ~ 199	Not Used		

**Note 1:** Function Parameter No. 070 (Line Error)-Transmit condition of RTP/PIP or RTN/PIN

Signal	Setting					
	1:128	2:256	3:512	4:1024	5:2048	6:Off
MCF/PIP	0-31	0-63	0-127	0-255	0-511	Always
RTP/PIP	32-63	64-127	128-255	256-511	512-1023	-
RTN/PIN	64-127	128-255	256-511	512-1023	1024-2047	-

**Note 2:** Function Parameter No. 071 (Total Error)-Transmit condition of RTP/PIP or RTN/PIN

Signal	Setting			
	1:5%	2:10%	3:15%	4:20%
MCF/PIP	0-2	0-4	0-7	0-9
RTP/PIP	3-4	5-9	8-14	10-19
RTN/PIN	5-	10-	15-	20-

**Note 3:** The default setting of parameters depends on the destination's specifications or regulations. Print the Function Parameter List to confirm the default settings.

**Note 4:**

Continuous Polling (Station Mode)

This feature allows you to store or add documents into a polled file in memory.

To enable the Continuous Polling feature set Function Parameter No. 003 to "2:Station". The Program Key [P4] will be assigned with the "Store-4-Polling" name automatically and cannot be changed.

To prepare the document(s) to be polled, simply place the document(s) on the ADF and then press the Program Key [P4] to store or add the document(s) into a polled file.

**(Note:** If a regular polled file ([FUNCTION][3][2]) is stored in memory, the Program Key [P4] for Continuous Polling will not be accepted.)

### 5.1.3. Service Mode 3 (Printout of Lists, Reports and Test Results)

From this Service Mode you can print the Function Parameter List, Page Memory Test, Printer Report, All Document File, Protocol Trace and the Toner Order Form.

#### 5.1.3.1. Function Parameter List

A list of all Function Parameters can be printed by the following procedure.

Service Mode 3 - Function Parameter List		
Step	Operation or Unit Condition	LCD Display
1	Standby	MMM-dd-yyyy 15:00 00%
2	Press "FUNCTION" and then "7".	SET MODE (1-6) ENTER NO. OR V Λ
3	Press "MONITOR" four times, then press "*".	SERVICE MODE ENTER NO. OR V Λ
4	Press "3".	PRINTOUT (1-7) 1:FUNC. PARAM. LIST
5	Press "START".	* PRINTING * FUNC. PARAMETER LIST
6	After printing is completed, the unit returns to the display in step 3.	SERVICE MODE ENTER NO. OR V Λ
7	Press "STOP" to return to standby.	MMM-dd-yyyy 15:00 00%

## Function Parameter List (Sample)

\*\*\*\*\* -FUNCTION PARAMETER- \*\*\*\*\* DATE MMM-dd-yyyy \*\*\*\*\* TIME 12:07 \*\*\* P.01

000 MON/TEL DIAL:[Monitor] Monitor	050 RING DET MODE:[Normal] Normal
001 ALARM STATUS:[Timer] Timer	051 -----
002 STOP COMM.JRNL:[On] On	052 PULSE RATE:[10pps] 10pps
003 CONTINUOUS POLL:[Off] Off	053 -----
004 NUMERIC ID SET:[On] On	054 -----
005 -----	055 BUSY TONE CHECK:[On] On
006 ID DISPLAY:[Chara] Chara	056 -----
007 JNL COLUMN:[Station] Station	057 -----
008 MONITOR:[Off] Off	058 COMM. JRNL +IMAGE:[Off] Off
009 DC LOOP:[Off] Off	059 CONF.RCV REPORT:[On] On
010 TX LEVEL:[-9dBm] -9dBm	060 VERSION:
011 RX LEVEL:[-43dBm] -43dBm	061 TX/RX/PRT/CPY:000050/000058/000074/000001
012 DTMF LEVEL:[-5dBm] -5dBm	062 PRINT COUNTER:[Off] Off
013 G3 RX EQL:[Off] Off	063 -----
014 G3 TX EQL:[Off] Off	064 SILENT DET.T.OUT:[60] 60
015 -----	065 SILENT INT. TIME:[5sec] 5sec
016 -----	066 RING COUNT(TAM):[5] 5
017 TX START:[14400bps ] 14400bps	067 -----
018 RX START:[14400bps ] 14400bps	068 NYSE FAX FORWARD:[Off] Off
019 ITU-T V34:[On] On	069 NYSE LOCAL PRINT:[Inc] Inc
020 ITU-T ECM:[On] On	070 LINE ERROR:[128] 128
021 EP TONE:[Off] Off	071 TOTAL ERROR:[ 10] 10
022 SIG. INTERVAL:[500ms] 500ms	072 CONTI. ERROR:[Off] Off
023 TCF CHECK:[Normal] Normal	073 ERROR DETECT:[Rate] Rate
024 CED FREQ.: [2100Hz] 2100Hz	074 RTN RECEIVE:[Discon] Discon
025 COMM. START-UP:[1'st] 1'st	075 MH/MR/MMR:[MMR] MMR
026 NON-STANDARD:[On] On	076 -----
027 SHORT PROTOCOL B:[On] On	077 RX JAM LENGTH:[Off] Off
028 SHORT PROTOCOL D:[On] On	078 -----
029 REMOTE DIAG.: [On] On	079 -----
030 CED & 300bps:[75ms] 75ms	080 -----
031 RTC=EQL x 12:[Off] Off	081 DOC END FEED:[0.0mm] 0.0mm
032 V34 TX START:[33600bps] 33600bps	082 JAM LENGTH:[ 2 m] 2 m
033 V34 RX START:[33600bps] 33600bps	083 -----
034 V34 TX SR:[3429sr] 3429sr	084 LINE AS NOPAPER:[Ring] Ring
035 V34 RX SR:[3429sr] 3429sr	085 -----
036 -----	086 -----
037 PROTOCOL DISPLAY:[Off] Off	087 DARKER LEVEL:[4] 4
038 -----	088 NORMAL LEVEL:[8] 8
039 FLASH TIME:[50] 500ms	089 LIGHTER LEVEL:[12] 12
040 -----	090 -----
041 PAUSE TIME:[3] 3 sec	091 -----
042 -----	092 SMOOTHING:[On] On
043 REDIAL INTERVAL:[3] 3 min	093 -----
044 REDIAL COUNT:[5] 5	094 -----
045 RING DET. COUNT:[2] 2	095 -----
046 ON-HOOK TIME:[5] 5 sec	096 -----
047 RESPONSE WAIT:[60] 60 sec	097 -----
048 -----	098 -----
049 -----	099 -----

Note:The power must be reset for the new parameter settings to take effect.

- PANASONIC -

\*\*\*\*\* - PANAFAX - \*\*\*\*\* - 12345678901234567890 -\*\*\*\*\*

## Function Parameter List (Sample)

```

***** -FUNCTION PARAMETER- ***** DATE MMM-dd-yyyy ***** TIME 12:07 ***P.02

100 ----- 150 -----
101 ----- 151 -----
102 ----- 152 -----
103 ----- 153 -----
104 ----- 154 -----
105 ----- 155 -----
106 ----- 156 -----
107 ----- 157 -----
108 ----- 158 -----
109 ----- 159 -----

110 ----- 160 -----
111 ----- 161 -----
112 ----- 162 -----
113 ----- 163 -----
114 ----- 164 -----
115 ----- 165 -----
116 ----- 166 -----
117 ----- 167 -----
118 ----- 168 -----
119 ----- 169 -----

120 ----- 170 -----
121 ----- 171 -----
122 ----- 172 -----
123 ----- 173 -----
124 ----- 174 -----
125 ----- 175 -----
126 ----- 176 -----
127 ----- 177 -----
128 ----- 178 -----
129 ----- 179 -----

130 BUSY-ACK TIMING:[In Busy] In Busy 180 -----
131 CMD RCV GRD TIMER:[3min] 3min 181 -----
132 PRT DATA TIMER:[3min] 3min 182 -----
133 COLLATION(PRT):[Off] Off 183 -----
134 COLLATION(PC):[Auto] Auto 184 -----
135 ----- 185 -----
136 ----- 186 -----
137 ----- 187 -----
138 ----- 188 -----
139 ----- 189 -----

140 ----- 190 -----
141 ----- 191 -----
142 ----- 192 -----
143 ----- 193 -----
144 ----- 194 -----
145 ----- 195 -----
146 ----- 196 -----
147 ----- 197 -----
148 ----- 198 -----
149 ----- 199 -----

```

Note:The power must be reset for the new parameter settings to take effect.

-PANASONIC -

\*\*\*\*\* -PANAFAX - \*\*\*\*\* -12345678901234567890- \*\*\*\*\*

**Note:**

1. [ ] - Factory Default
2. The contents of the Function Parameter List may vary depending on the destination's regulations.
3. " \* " mark will be shown on the left side of number when setting was changed from default.

### 5.1.3.2. Page Memory Test

A test pattern prints out for checking the page memory and the printer mechanism using the following procedure.

Service Mode 3 - Page Memory Test		
Step	Operation or Unit Condition	LCD Display
1	Standby	MMM-dd-yyyy 15:00 00%
2	Press "FUNCTION" and then "7".	SET MODE (1-6) ENTER NO. OR √Λ
3	Press "MONITOR" four times, then press "*".	SERVICE MODE ENTER NO. OR √Λ
4	Press "3".	PRINTOUT (1-7) 1:FUNC. PARAM. LIST
5	Press "3" and "START".	* PRINTING * PAGE MEMORY TEST
6	After printing is completed, the unit returns to the display in step 3.	SERVICE MODE ENTER NO. OR √Λ
7	Press "STOP" to return to standby.	MMM-dd-yyyy 15:00 00%

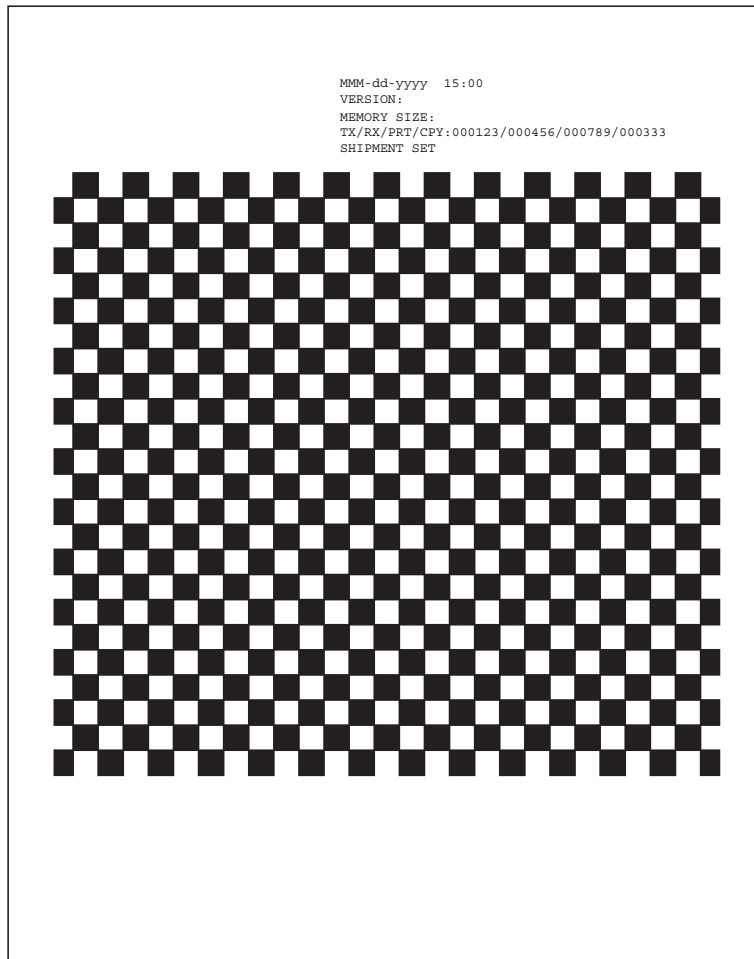

### 5.1.3.3. Printer Report

All printer errors are logged on the Printer Report which can be printed by the following procedure.

Service Mode 3 - Printer Report		
Step	Operation or Unit Condition	LCD Display
1	Standby	MMM-dd-yyyy 15:00 00%
2	Press "FUNCTION" and then "7".	SET MODE (1-6) ENTER NO. OR V Λ
3	Press "MONITOR" four times, then press "*".	SERVICE MODE ENTER NO. OR V Λ
4	Press "3".	PRINTOUT (1-7) 1:FUNC. PARAM. LIST
5	Press "4" and "START".	* PRINTING * PRINTER REPORT
7	After printing is completed, the unit returns to the display in step 3.	SERVICE MODE ENTER NO. OR V Λ
8	Press "STOP" to return to standby.	MMM-dd-yyyy 15:00 00%

\*\*\*\*\*-PRINTER REPORT-\*\*\*\*\* DATE MMM-dd-yyyy \*\*\*\*\* TIME 19:02\*\*\*\*\*

LAST PRINT ERROR : MMM-dd 15:38 NO. 001-12

CUSTOMER ID : 1234567890123456

FAX ROM VERSION :

TRANSMIT COUNTER : 000475

RECEIVE COUNTER : 000398

COPY COUNTER : 001083

PRINT COUNTER : 001575

PRINT ERROR : 1.MMM-dd-yyyy 15:38 NO.001-12

2.MMM-dd-yyyy 10:48 NO.001-11

3.MMM-dd-yyyy 15:23 NO.004-36

- PANASONIC -

\*\*\*\*\* - PANAFAX - \*\*\*\*\* - 12345678901234567890 - \*\*\*\*\*



## 1. Printer Error Code Table

Error Code	Description of Problems	Cause
00	No problem detected.	
11	Timing Sensor did not turn ON within a certain period of time. (Original Cassette Feeder)	1. Recording Paper misfeeding, Paper Feed Roller defective. 2. Drive Clutch defective. 3. Timing Sensor defective.
12	Timing Sensor did not turn ON within a certain period of time. (250 sheet Optional Cassette Feeder)	1. Recording Paper misfeeding, Paper Feed Roller defective. 2. Drive Clutch defective. 3. Timing Sensor defective.
14	Timing Sensor did not turn OFF within a certain period of time.	1. Recording Paper Jam. 2. Timing Sensor defective. 3. Incorrect paper size setting.
15	Paper Exit Sensor did not turn ON within a certain period of time.	1. Recording Paper Jam. 2. Paper Exit Sensor defective.
16	Paper Exit Sensor did not turn OFF within a certain period of time.	1. Recording Paper Jam. 2. Paper Exit Sensor defective.
17	Timing Sensor detected paper while initializing the unit.	1. Recording Paper jammed in the unit. 2. Timing Sensor defective.
18	Paper Exit Sensor detected paper while initializing the unit.	1. Recording Paper jammed in the unit. 2. Paper Exit Sensor defective.
22	The temperature of the Fuser Roller remained low even after the circuit was activated.	1. Fuser Unit defective. 2. SC PCB defective. 3. Power Supply Unit defective.
23	Abnormally high Fuser Roller temperature after the circuit was de-activated.	1. Fuser Unit defective. 2. SC PCB defective. 3. Power Supply Unit defective.
24	The temperature of the Fuser Roller was not controlled within a certain margin.	1. Fuser Unit defective. 2. SC PCB defective. 3. Power Supply Unit defective.
25	Thermistor open. (See Note)	1. Thermistor defective (Fuser Unit). 2. SC PCB defective.
26	Thermistor detected temperature over 392°F (200°C). (See Note)	1. Thermistor defective (Fuser Unit). 2. SC PCB defective. 3. Power Supply Unit defective.
31	The Tetragon Motor did not reach a constant speed of 8,898 rpm (400dpi)/13,347 rpm (600dpi) within a specified period of time.	1. LSU defective.
32	The Tetragon Motor did not maintain a constant speed of 8,898 rpm (400dpi)/13,347 rpm (600dpi).	1. LSU defective.
36	HSYNC signal abnormal.	1. LSU defective. 2. SC PCB defective.
54	A/D Converter error.	1. SC PCB defective.
61	Unit detected "No Toner Cartridge".	1. Toner Cartridge not installed. 2. Toner Sensor defective.
63	Unit detected "Printer Cover Open".	1. Printer Cover is not closed. 2. ILS PCB defective.

<b>Error Code</b>	<b>Description of Problems</b>	<b>Cause</b>
64	Unit detected "No Cassette".	1. Cassette not installed or partially open. 2. Cassette Sensor defective.
65	Unit detected "Out of Paper".	1. The Paper Cassette is empty. 2. Paper Detect Sensor defective.
81	No response from LP Controller.	1. SC PCB defective.
82	Illegal response from LP Controller.	1. SC PCB defective.

**Note:**

If an 021 series Error Code occurs, 021-25 (Thermistor Open) or 021-26 (Thermistor detected temperature over 392°F (200°C)), a pre-programmed recovery safety software is activated to protect the unit and the service personnel during abnormal increase in temperature.

Once activated, this program is downloaded into the LPC PC Board's SRAM, disabling the Fuser Lamp and preventing it from turning ON again.

In order to reset this circuit, please follow the procedure below.

- 1) Reset the LBP Fuser by using Service Mode 7-1-2 (Section 5.1.7.) and unplug & plug-in the power cord.
- 2) Replace the Thermistor or Fuser Unit. If the problem persists.
- 3) Replace the SC PCB.

## 2. Printer Error Detail Explanation

### Recording Paper Jam Detection

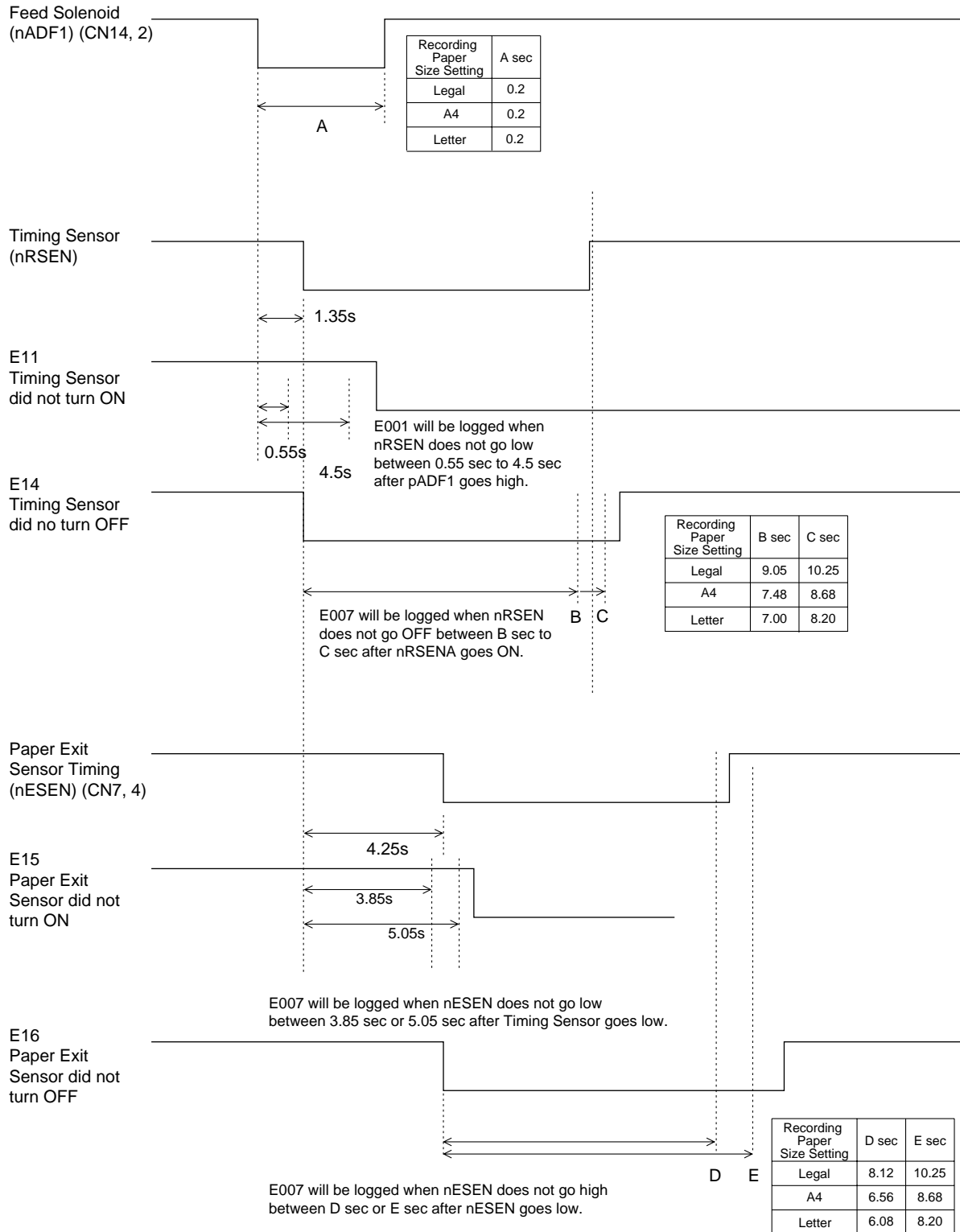

# Fuser Error Detection

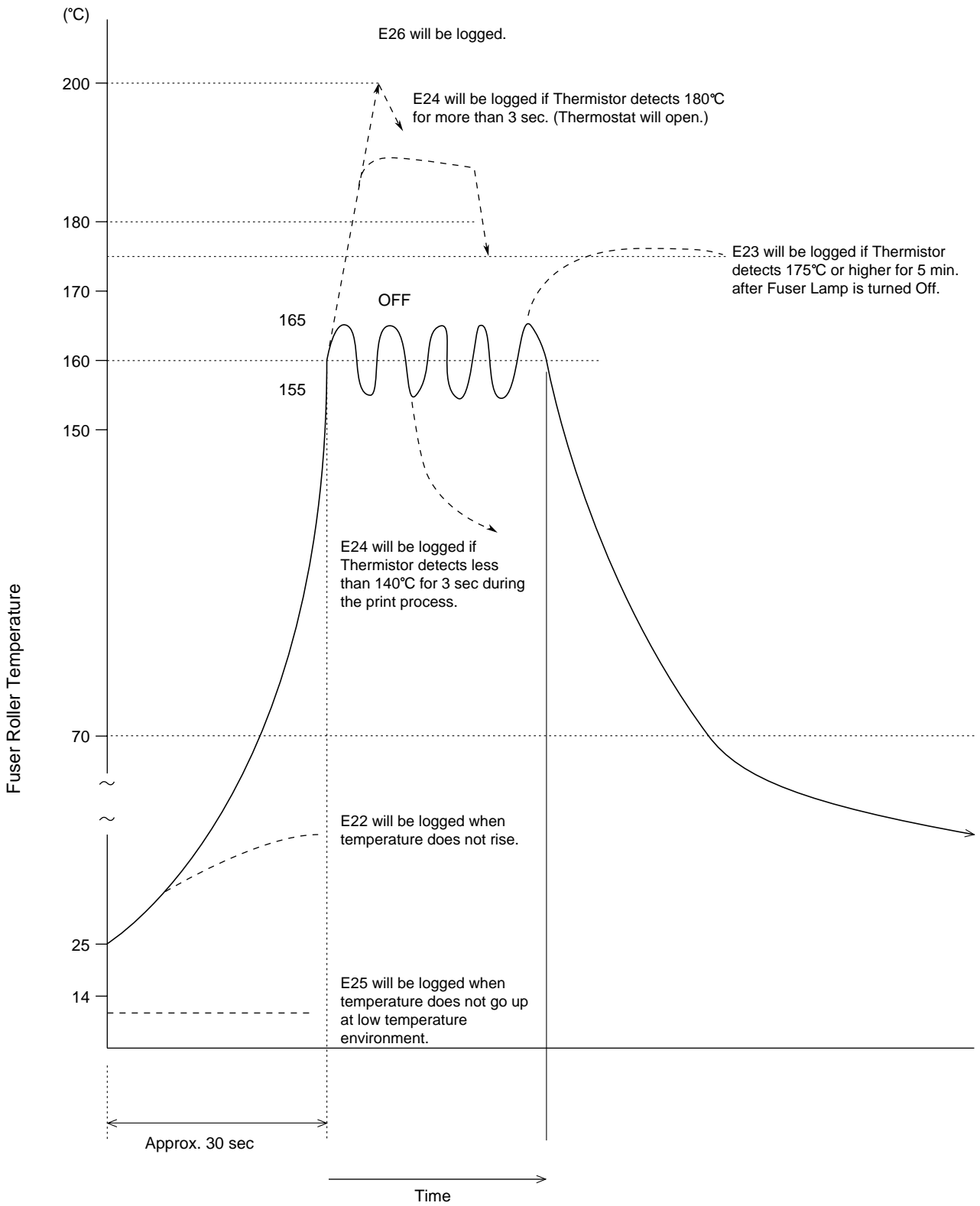

# Laser Unit (LSU) Error Detection

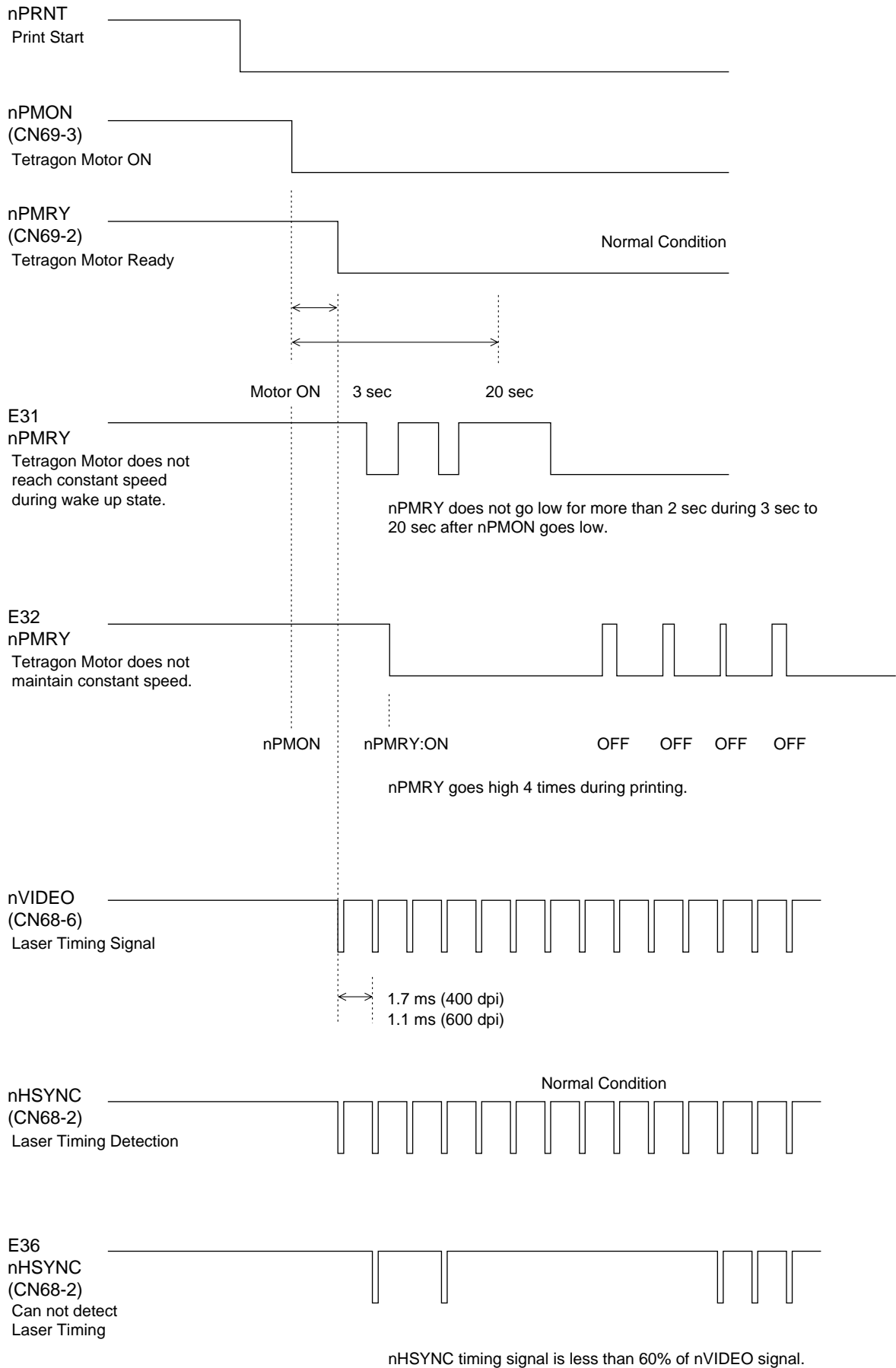

## Out of Toner Detection

Toner Sensor Output Signal

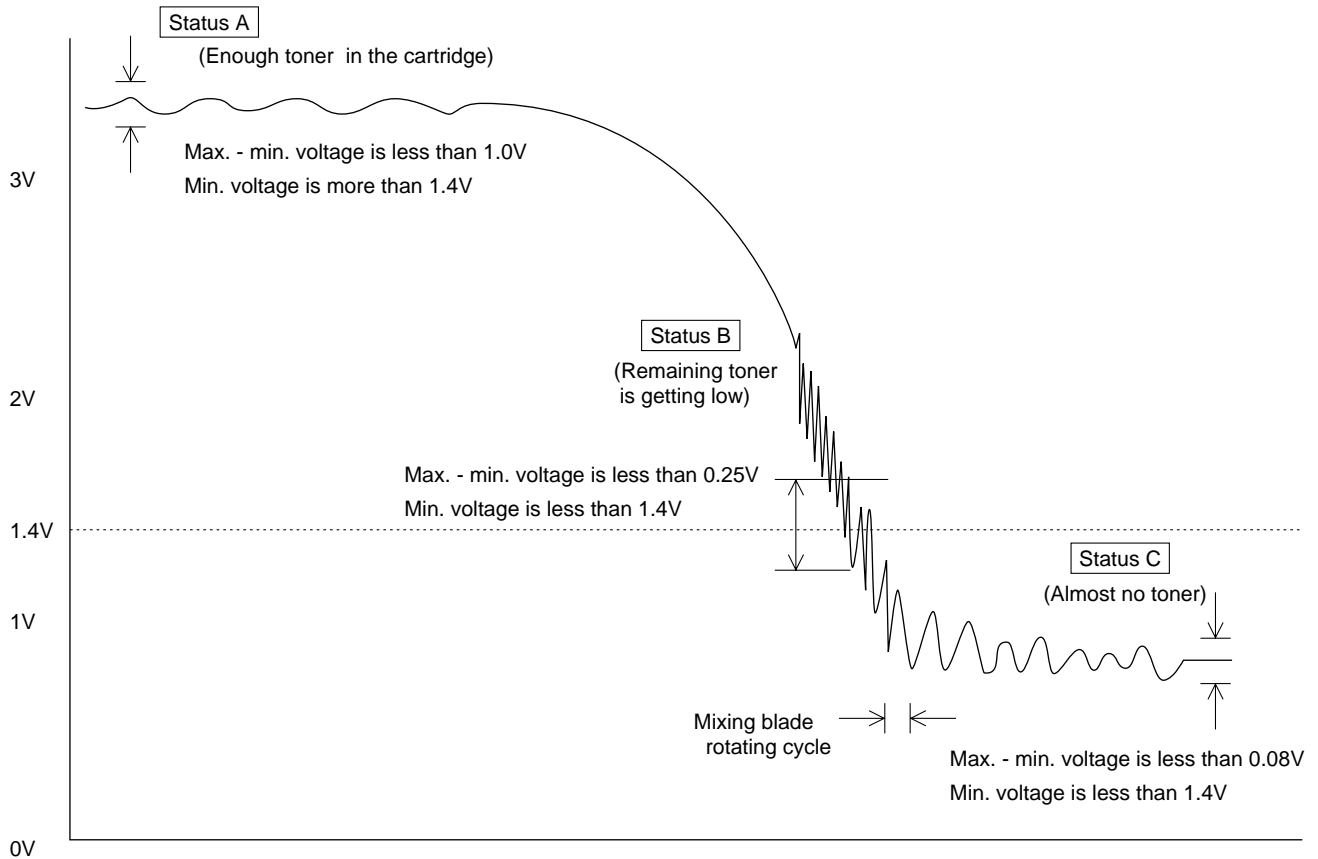

Toner Sensor output may change when the mixing blade passes above the Toner Sensor. Therefore the output signal has a max. voltage and min. voltage during mixing blade rotation cycle (4.6 sec.).

### E043

If the unit detects Status B, 10 times during printing, the machine recognizes that the remaining toner is low and the display shows "REPLACE TONER CARTRIDGE".

### E041

After detecting E043 and the LBP Print Available Counter Value reaches "0" (after 100 pages are printed), the unit logs E041 (OUT OF TONER).

### E045

If the unit detects Status C when power is On, the unit logs E045 and displays "NO CARTRIDGE". The unit will recover when detecting Status A after a new toner cartridge is installed.

### 5.1.3.4. All Document Files

Print the document files from the Flash Memory.

Service Mode 3 - All Document Files		
Step	Operation or Unit Condition	LCD Display
1	Standby	MMM-dd-yyyy 15:00 00%
2	Press "FUNCTION" and then "7".	SET MODE (1-6) ENTER NO. OR VΛ
3	Press "MONITOR" four times, then press "*".	SERVICE MODE ENTER NO. OR VΛ
4	Press "3".	PRINTOUT (1-7) 1:FUNC. PARAM. LIST
5	Press "5" and "START".	* PRINTING * ALL DOCUMENT FILES
6	After printing is completed, the unit returns to the display in step 3.	SERVICE MODE ENTER NO. OR VΛ
7	Press "STOP" to return to standby.	MMM-dd-yyyy 15:00 00%

**Note:**

Documents received with a Confidential Code will not be printed by this operation.

### 5.1.3.5. Protocol Trace

Print a Protocol Trace Report for the previous communication.

Service Mode 3 - Protocol Trace		
Step	Operation or Unit Condition	LCD Display
1	Standby	MMM-dd-yyyy 15:00 00%
2	Press "FUNCTION" and then "7".	SET MODE (1-6) ENTER NO. OR VΛ
3	Press "MONITOR" four times, then press "*".	SERVICE MODE ENTER NO. OR VΛ
4	Press "3".	PRINTOUT (1-7) 1:FUNC. PARAM. LIST
5	Press "6" and "START". <b>Note:</b> If there were no transmission or reception mode after the power is last turned on, you cannot print the Protocol Trace Report.	* PRINTING * PROTOCOL TRACE
6	After printing is completed, the unit returns to the display in step 3.	SERVICE MODE ENTER NO. OR VΛ
7	Press "STOP" to return to standby.	MMM-dd-yyyy 15:00 00%



\*\*\*\*\* PROTOCOL LOG REPORT \*\*\*\*\* DATE MMM-dd-yyyy \*\*\*\*\* TIME 16:56 \*\*\*P.01

STATUS : OK  
MODE : ECM-TX (STANDARD)  
SPEED : 9600bps 00MS/L  
REMOTE CAPA. : DIS 00 CE B9 C4 80 12  
LOCAL CAPA. : TSI 2B 20 20 20 38 37 2B 2B 2B 2B  
              39 38 36 36 35 34 37 38 38 30  
              DCS 00 C6 F8 44

COMMAND LOG.

REMOTE : NSF CSI DIS CFR  
LOCAL : TSI DCS PIX PPS-EOP

-----  
REMOTE : MCF  
LOCAL : DCN

-PANASONIC-

\*\*\*\*\* -PANAFAX - \*\*\*\*\*-12345678901234567890-\*\*\*\*\*

### 5.1.3.6. Toner Cartridge Order Form

The Toner Cartridge Order Form can be printed out manually by the following procedure.

Service Mode 3 - Toner Cartridge Order Form		
Step	Operation or Unit Condition	LCD Display
1	Standby	MMM-dd-yyyy 15:00 00%
2	Press "FUNCTION" and then "7".	SET MODE (1-6) ENTER NO. OR √Λ
3	Press "MONITOR" four times, then press "*".	SERVICE MODE ENTER NO. OR √Λ
4	Press "3".	PRINTOUT (1-7) 1:FUNC. PARAM. LIST
5	Press "7" and "START".	* PRINTING * TONER ORDER FORM
6	After printing is completed, the unit returns to the display in step 3.	SERVICE MODE ENTER NO. OR √Λ
7	Press "STOP" to return to standby.	MMM-dd-yyyy 15:00 00%

**For USA and Canada**

```

*****
> TONER CARTRIDGE ORDER FORM <
*****

**** The toner supply in your facsimile machine is running low **** (1)
To order a replacement Cartridge from your Authorized Dealer

Panafax Corp. (2)

by Phone: 1 201 111 5555 (3)
by Fax: 1 201 111 4444 (4)

Thank you for your order.

Customer Name and Address
=====

Ship to: _____ Bill to: _____
_____
_____

Attention: _____ Attention: _____
Phone No.: _____ Phone No.: _____

Customer ID: ABC COMPANY (5) P.O. No.(if required): _____
Toner Cartridge: UG-5510 (6) Serial No.: _____

Quantity Required:
[ ]

_____ / /
Print your name and title Signature & Date

```

**Explanation of Contents**

- |                               |   |
|-------------------------------|---|
| (1) Low Toner Message (Fixed) | “The toner supply in your machine is running low” |
| (2) Dealer Name               | Up to 25 digits                                   |
| (3) Order Tel #               | Up to 36 digits                                   |
| (4) Order Fax #               | Up to 36 digits                                   |
| (5) Customer ID               | Up to 16 characters (User Identification Code)    |
| (6) Toner Cartridge #         | UG-5510 (For USA / Canada) for UF-780/790/6000    |

**For Other Destinations**

```

*****
> TONER CARTRIDGE ORDER FORM <
*****

**** The toner supply in your facsimile machine is running low **** (1)
      To order a replacement Cartridge from your Authorized Dealer

                Panafax Corp. (2)

      by Phone:  1 201 111 5555 (3)
      by Fax:    1 201 111 4444 (4)

                Thank you for your order.

                Customer Name and Address
                =====

Ship to: _____ Bill to: _____
_____
_____

Attention: _____ Attention: _____
Phone No.: _____ Phone No.: _____
Customer ID: ABC COMPANY (5) P.O. No.(if required): _____
Toner Cartridge: UG-3350 (6) Serial No.: _____

                Quantity Required:
                [ ]

_____ / /
Print your name and title Signature & Date

```

**Explanation of Contents**

- |                               |   |
|-------------------------------|---|
| (1) Low Toner Message (Fixed) | “The toner supply in your machine is running low”         |
| (2) Dealer Name               | Up to 25 digits   |
| (3) Order Tel #               | Up to 36 digits   |
| (4) Order Fax #               | Up to 36 digits   |
| (5) Customer ID               | Up to 16 characters (User Identification Code)            |
| (6) Toner Cartridge #         | UG-3350 (For Other Destinations) for UF-580/590/5100/6100 |

## 5.1.4. Service Mode 4 (Modem Test)

### 5.1.4.1. Binary Signal

This Service Mode is used to check the binary signal output. Signals can be output to the line using the following procedure.

Service Mode 4 - Binary Signal		
Step	Operation or Unit Condition	LCD Display
1	Standby	MMM-dd-yyyy 15:00 00%
2	Press "FUNCTION" and then "7".	SET MODE (1-6) ENTER NO. OR V Λ
3	Press "MONITOR" four times, then press "*".	SERVICE MODE ENTER NO. OR V Λ
4	Press "4".	MODEM TEST (1-5) 1: SIGNAL TEST
5	Press "START".	SIGNAL TEST IDLE (ENTER 1-9)
6	Enter the signal number (1-9) to select the binary signal.	SIGNAL TEST 300bps
7	Press "CLEAR" to end the signal generation. To select another signal, repeat step 6.	SIGNAL TEST IDLE (ENTER 1-9)
8	Press "STOP" twice to return to standby.	MMM-dd-yyyy 15:00 00%

Binary Signal Table

Number	Signals
1	V21 300bps
2	V27ter 2400bps
3	V27ter 4800bps
4	V29 7200bps
5	V29 9600bps
6	V17 TC7200bps
7	V17 TC9600bps
8	V33 12000bps
9	V33 14400bps

### 5.1.4.2. Tonal Signal

This Service Mode is used to check the tonal signal output. Signals can be output to the line using the following procedure.

Service Mode 4 - Tonal Signal		
Step	Operation or Unit Condition	LCD Display
1	Standby	MMM-dd-yyyy 15:00 00%
2	Press "FUNCTION" and then "7".	SET MODE (1-6) ENTER NO. OR √Λ
3	Press "MONITOR" four times, then press "*".	SERVICE MODE ENTER NO. OR √Λ
4	Press "4".	MODEM TEST (1-5) 1:SIGNAL TEST
5	Press "2" and "START".	TONAL TEST IDLE (ENTER 1-7)
6	Enter the signal number (1-7) to select the binary signal.	TONAL TEST 1080Hz
7	Press "CLEAR" to end the signal generation. To select another signal, repeat step 6.	TONAL TEST IDLE (ENTER 1-7)
8	Press "STOP" twice to return to standby.	MMM-dd-yyyy 15:00 00%

Tonal Signal Table

Number	Signals
1	462 Hz
2	1080 Hz
3	1100 Hz
4	1300 Hz
5	1650 Hz
6	1850 Hz
7	2100 Hz

### 5.1.4.3. DTMF Signal

This Service Mode is used to check the DTMF (Dual Tone Multi Frequency) signal output. The DTMF signal can be generated using the following procedure.

Service Mode 4 - DTMF Signal		
Step	Operation or Unit Condition	LCD Display
1	Standby	MMM-dd-yyyy 15:00 00%
2	Press "FUNCTION" and then "7".	SET MODE (1-6) ENTER NO. OR V Λ
3	Press "MONITOR" four times, then press "*".	SERVICE MODE ENTER NO. OR V Λ
4	Press "4".	MODEM TEST (1-5) 1: SIGNAL TEST
5	Press "3" and "START".	DTMF TEST (1-2) 1. SINGLE
6a	Press "START" for DTMF Single Tone Generation.	SINGLE TONE ENTER (1-8)
7a	Enter the signal number (1-8) to select the DTMF signal.	SINGLE TONE 697Hz
6b	Press "2" and "START" for Dual Tone Generation.	DUAL TONE ENTER (0-#)
7b	Enter the signal number (0-#) to select the DTMF Dual tone.	DUAL TONE (0)
8	Press "CLEAR" to end the signal generation. To select another signal, repeat step 7a or 7b.	SINGLE TONE ENTER (1-8)
9	Press "STOP" twice to return to standby.	MMM-dd-yyyy 15:00 00%

DTMF Single Tone Table

Number	DTMF Signal Tones
1	697 Hz
2	770 Hz
3	852 Hz
4	941 Hz
5	1209 Hz
6	1336 Hz
7	1477 Hz
8	1633 Hz

DTMF Dual Tone Table

Number	DTMF Dual Tones
0	941 Hz + 1336 Hz
1	697 Hz + 1209 Hz
2	697 Hz + 1336 Hz
3	697 Hz + 1477 Hz
4	770 Hz + 1209 Hz
5	770 Hz + 1336 Hz
6	770 Hz + 1477 Hz
7	852 Hz + 1209 Hz
8	852 Hz + 1336 Hz
9	852 Hz + 1477 Hz
*	941 Hz + 1209 Hz
#	941 Hz + 1477 Hz

#### 5.1.4.4. Binary Signal (V.34)

This Service Mode is used to check the binary signal output. Signals can be output to the line using the following procedure. (V.34)

Service Mode 4 - Binary Signal		
Step	Operation or Unit Condition	LCD Display
1	Standby	MMM-dd-yyyy 15:00 00%
2	Press "FUNCTION" and then "7".	SET MODE (1-6) ENTER NO. OR VΛ
3	Press "MONITOR" four times, then press "*".	SERVICE MODE ENTER NO. OR VΛ
4	Press "4".	MODEM TEST (1-5) 1: SIGNAL TEST
5	Press "5" and "START".	V.34 MODEM TEST ENTER NO. ■
6	Enter the signal number (01-61) and press [START] to select the binary signal.	V.34 MODEM TEST V34 2400sr 2400bps
7	Press "CLEAR" to end the signal generation. To select another signal, repeat step 6.	V.34 MODEM TEST ENTER NO. ■
8	Press "STOP" twice to return to standby.	MMM-dd-yyyy 15:00 00%

Binary Signal Table

Number	Signals	Number	Signals	Number	Signals
01	V34 2400 sr 2400 bps	22	V34 3000 sr 9600 bps	43	V34 3429 sr 4800 bps
02	V34 2400 sr 4800 bps	23	V34 3000 sr 12000 bps	44	V34 3429 sr 7200 bps
03	V34 2400 sr 7200 bps	24	V34 3000 sr 14400 bps	45	V34 3429 sr 9600 bps
04	V34 2400 sr 9600 bps	25	V34 3000 sr 16800 bps	46	V34 3429 sr 12000 bps
05	V34 2400 sr 12000 bps	26	V34 3000 sr 19200 bps	47	V34 3429 sr 14400 bps
06	V34 2400 sr 14400 bps	27	V34 3000 sr 21600 bps	48	V34 3429 sr 16800 bps
07	V34 2400 sr 16800 bps	28	V34 3000 sr 24000 bps	49	V34 3429 sr 19200 bps
08	V34 2400 sr 19200 bps	29	V34 3000 sr 26400 bps	50	V34 3429 sr 21600 bps
09	V34 2400 sr 21600 bps	30	V34 3000 sr 28800 bps	51	V34 3429 sr 24000 bps
10	V34 2800 sr 4800 bps	31	V34 3200 sr 4800 bps	52	V34 3429 sr 26400 bps
11	V34 2800 sr 7200 bps	32	V34 3200 sr 7200 bps	53	V34 3429 sr 28800 bps
12	V34 2800 sr 9600 bps	33	V34 3200 sr 9600 bps	54	V34 3429 sr 31200 bps
13	V34 2800 sr 12000 bps	34	V34 3200 sr 12000 bps	55	V34 3429 sr 33600 bps
14	V34 2800 sr 14400 bps	35	V34 3200 sr 14400 bps	56	ANSam
15	V34 2800 sr 16800 bps	36	V34 3200 sr 16800 bps	57	CM
16	V34 2800 sr 19200 bps	37	V34 3200 sr 19200 bps	58	JM
17	V34 2800 sr 21600 bps	38	V34 3200 sr 21600 bps	59	INFO0c & TONEB
18	V34 2800 sr 24000 bps	39	V34 3200 sr 24000 bps	60	INFO0c & TONEA
19	V34 2800 sr 26400 bps	40	V34 3200 sr 26400 bps	61	PPh & AC & ALT
20	V34 3000 sr 4800 bps	41	V34 3200 sr 28800 bps		
21	V34 3000 sr 7200 bps	42	V34 3200 sr 31200 bps		



## 5.1.5. Service Mode 5 (Diagnostic)

### 5.1.5.1. CCD Test

This Service Mode is used to check the CCD.  
Use the following procedure to initiate the test.

Service Mode 5		
Step	Operation or Unit Condition	LCD Display
1	Standby	MMM-dd-yyyy 15:00 00%
2	Press "FUNCTION" and then "7".	SET MODE (1-6) ENTER NO. OR V Λ
3	Press "MONITOR" four times, then press "*".	SERVICE MODE ENTER NO. OR V Λ
4	Press "5".	DIAGNOSTIC (1-3) 1:CCD TEST
5	Press "START". The Scanner will be active.	1:CCD TEST * CHECK NOW *
6	Press "STOP" twice to return to standby.	MMM-dd-yyyy 15:00 00%

### 5.1.5.2. LCD / LED Test

This Service Mode is used to check the LCD and LEDs on the Control Panel.

Use the following procedure to initiate the test.

Service Mode 5		
Step	Operation or Unit Condition	LCD Display
1	Standby	MMM-dd-yyyy 15:00 00%
2	Press "FUNCTION" and then "7".	SET MODE (1-6) ENTER NO. OR VΛ
3	Press "MONITOR" four times, then press "**".	SERVICE MODE ENTER NO. OR VΛ
4	Press "5".	DIAGNOSTIC (1-3) 1:CCD TEST
5	Press "2" and "START". 1) LCDs display as shown at right. 2) All LEDs will be lit.	2:LCD/LED TEST * CHECK NOW * 
6	Press "STOP" twice to return to standby.	MMM-dd-yyyy 15:00 00%

### 5.1.6. Service Mode 6 (RAM Initialization)

Initializes the RAM and restores the Function Parameters to their default values.

**Note:**

This operation should be performed when the unit is first installed.

Service Mode 6		
Step	Operation or Unit Condition	LCD Display
1	Standby	MMM-dd-yyyy 15:00 00%
2	Press "FUNCTION" and then "7".	SET MODE (1-6) ENTER NO. OR V ^
3	Press "MONITOR" four times, then press "*".	SERVICE MODE ENTER NO. OR V ^
4	Press "6".	* RAM INITIALIZE * ENTER NO. OR V ^
5	Press "V" or "^" to select the initialization mode. (See Table)	* RAM INITIALIZE * LOGO/ID/PSWD CLEAR
6	Press "START".	LOGO/ID/PSWD CLEAR * COMPLETED *
7	Return to step 3 and press "STOP" to return to standby.	MMM-dd-yyyy 15:00 00%

RAM Initialization Table

No.	Initialize Mode	Description
99	SHIPMENT SET (A)	Deletes all setting information, except parameter number 80 and 81, then set default values. (See Note)
98	SHIPMENT SET (B)	Deletes all setting information, except parameter number 61, 80 and 81, then set default values. (See Note)
97	FLASH MEMORY CLEAR	Deletes all information in the Flash Memory.
16	LBP LOG CLEAR	Clears the Printer Error Log.
15	LOGO/ID/PSWD CLR	Clears the Logo, ID, Polling Password.
14	ALL JOB CLEAR	Clears all Jobs stored in Flash Memory.
13	PROG. DIAL CLEAR	Clears the Program keys.
12	AUTO DIAL CLEAR	Clears the One-touch, ABBR Numbers and Phone Books.
11	JOURNAL CLEAR	Clears the Journal contents.
*	PARAMETER INIT.	Restores the Fax and Function Parameters to default values.

### 5.1.7. Service Mode 7 (LBP Service Mode)

This Service Mode is used to change printer parameters and verify printer information.

Use the following procedure to change printer parameter.

Service Mode 7		
Step	Operation or Unit Condition	LCD Display
1	Standby	MMM-dd-yyyy 15:00 00%
2	Press "FUNCTION" and then "7".	SET MODE (1-6) ENTER NO. OR V ^
3	Press "MONITOR" four times, then press "*".	SERVICE MODE ENTER NO. OR V ^
4	Press "7".	LP SERVICE MODE (1-2) 1:LBP PARAMETER SET
5	1) Press "START" for printer parameter settings. Press "2" and "START" to get the printer information. Ex: Enter "START" for printer parameter settings.	LBP PARAMETER SET 1.PRINTER COUNTER
6	Press "3" and "START". Then enter the number of pages. Ex: Enter "50" and press "START".	LBP PARAMETER SET 3.OUT OF TONER
7	Press "V" or "^" to select another Parameter Name (See Table) or press "CLEAR" to return to step 4.	LP SERVICE MODE (1-2) 1.LBP PARAMETER SET
8	Repeat step 5 through 7 to request operation, or press "STOP" twice to return to standby.	MMM-dd-yyyy 15:00 00%

Sub-Code	Parameter Name	Description	
1	1	PRINTER COUNTER	Displays and resets the Printer and Paper Cassette(s) counters.
	2	LBP FUSER RESET	Clears the LBP Fuser Error.
	3	OUT OF TONER	Sets the number of pages to print after low toner is detected. (Factory default = 100, adjustable from 0 - 999)
2	V ^	PRINT AVAILABLE	Shows the remaining number of allowable printable pages after low toner has been detected (Counter Only).
	V ^	LBP MEMORY CAPACITY	Shows the Page Memory Capacity.

## 5.1.8. Service Mode 8 (Check & Call)

### 5.1.8.1. Overview

This feature enables the Authorized Servicing Dealers to manage and improve the Fax machine maintenance to their customers by alerting them of equipment problems. It also can be used as a Supply Sales Tool by alerting the Dealer that the unit is running Low on Toner. The function overview is as follows:

1. The machine's printer error information is stored in the Printer Report.
2. The printer report can be manually printed when required.
3. When printer errors occurs, the unit can automatically transmit the Service Alert Report to the pre-registered telephone number.
4. When the unit detects Low Toner, it can automatically transmit the Maintenance Alert Report to the pre-registered telephone number.
5. When the unit detects Low Toner, it can automatically print out the Toner Order Form with pre-registered order information.

### 5.1.8.2. Printer Reports

#### • Conditions under which a report can be printed or transmitted

1. Manually print  
The Printer Report can be printed by Service Mode 3. (See Sect. 5.1.3.1.)
2. Automatic transmission/printout
3. Service Alert Report  
When the unit detects an Emergency Printer Error, the unit will immediately transmit the Service Alert Report to the pre-registered telephone number. However, the unit will not transmit the Service Alert Report if it finds the same error within the same date in the error log.
4. Maintenance Alert Report  
When the unit detects Low Toner, the unit can automatically transmit the Maintenance Alert Report to the pre-registered telephone number. Refer to the Printer Error Code Table.
5. Toner Cartridge Order Form  
When the unit detects Low Toner, the unit can automatically print the Toner Order Form with the pre-registered order information.

#### Note:

The Service and Maintenance Alert Reports are managed in the same manner as the normal memory transmission (Retry, Incomplete, File List, Display while it is transmitting, Journal).

#### • Printer Error Code Table

Info. Code	Printer Error Code	LED/LCD	Log Only	Tx Report	Condition	Content of Error
001	11	JAM	O		R/C	Paper Jam 1st Cassette.
002	12	JAM	O		R/C	Paper Jam 2nd Cassette.
007	14-18	JAM	O		R/C	Paper Exit Error.
010	00	NO PAPER			R/C	No Paper in 1st or 2nd Cassette.
011	64, 65	NO Cassette			S	No 1st or 2nd Cassette.
021	22-26		O	S	R/C	Fuser Problem / LP Thermistor disconnected Problem
041	00	TONER	O		S/R/C	No Toner
043	00	TONER	O	M	S/R/C	Low Toner Warning
045	61	TONER	O		S	No Toner Cartridge
051	54		O	S	R/C	Printer Error

<b>Info. Code</b>	<b>Printer Error Code</b>	<b>LED/LCD</b>	<b>Log Only</b>	<b>Tx Report</b>	<b>Condition</b>	<b>Content of Error</b>
054	31,32,36		O	S	R/C	LSU Problem
055	81, 82		O	S	R/C	No response from LP Controller
060						Rx Door Open

**Note:**

1. Tx Report: S = Service Alert Report, M = Maintenance Alert Report
2. Condition : R = Receive Mode, C = Copy Mode, S = Standby Mode, T = Transmit Mode

### 5.1.8.3. Setting Operation

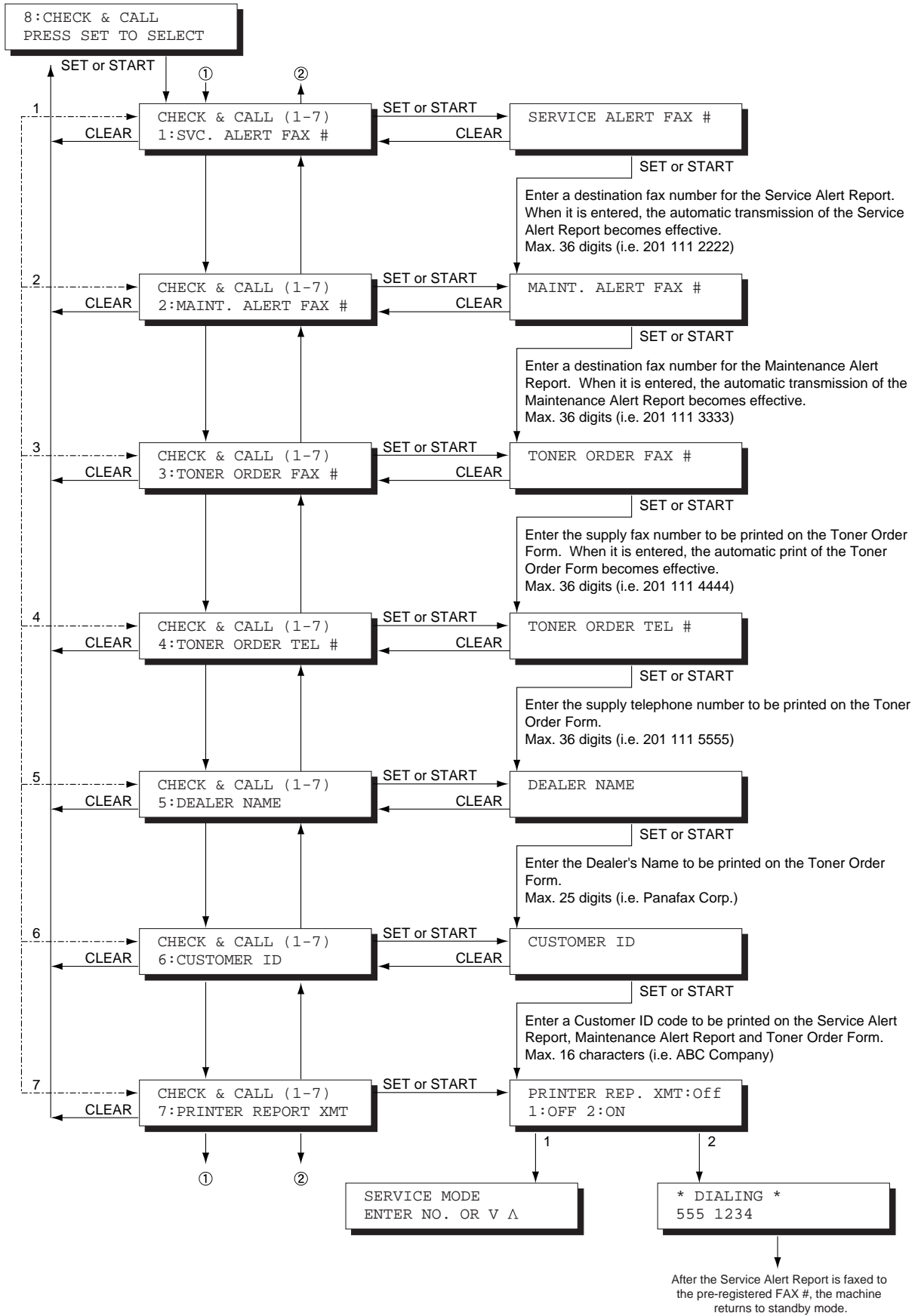

**Note****1. Service Alert Report**

To enable the automatic transmission of Service Alert Report, enter the destination fax telephone number in the "SERVICE ALERT (FAX #)" field. When a printer error occurs, the Service Alert Report is transmitted to the designated number automatically. A blank entry in this field, disables the Automatic transmission of the Service Alert Report.

**2. Maintenance Alert Report**

To enable the automatic transmission of Maintenance Alert Report, enter the destination fax telephone number in the "MAINT. ALERT (FAX #)" field. When a printer error occurs, the Maintenance Alert Report is transmitted to the designated number automatically. A blank entry in this field, disables the Automatic transmission of the Maintenance Alert Report.

**3. Toner Cartridge Order Form**

To enable the automatic printout of the Toner Cartridge Order Form, enter the destination fax telephone numbers in the "Order FAX #" field. When a low toner error occurs, the Toner Order Form is printed automatically.

**4. SERVICE ALERT FAX #**, this would be the fax telephone number for the Dealer's Service Department.

**MAINT. ALERT FAX #**, this could be the fax telephone number for the Dealer's Supply Sales Desk.

**ORDER FAX #**, this could be the fax telephone number for the Dealer's Supply Sales Desk.

**ORDER TEL #**, this could be the voice telephone number for the Dealer's Supply Sales Desk.

**DEALER NAME**, this name is printed on the Toner Order Form.

**CUSTOMER ID**, to identify your customer, enter up to 16 characters user code in this field. This name will be printed on the Service Alert Report, Maintenance Alert Report and Toner Order Form.

**5. Printer Report XMT**

To manually transmit the Service Alert Report to the pre-registered SERVICE ALERT REPORT FAX #, set the Printer Report XMT to "2:ON".





## 5.1.8.5. MAINTENANCE ALERT REPORT FORMAT

```
***** DATE MMM-dd-yyyy ***** TIME 12:14 *****
*****
> MAINTENANCE ALERT REPORT <
*****

LAST PRINT ERROR : MACHINE IS RUNNING OUT OF TONER (1)

CUSTOMER ID      : ABC COMPANY (2)

FAX ROM VERSION  :                               (3)

TRANSMIT COUNTER : 999999 (4)
RECEIVE COUNTER  : 999999
COPY COUNTER     : 999999
PRINT COUNTER    : 999999

                                -LOGO PANASONIC -

***** -CHARACTER ID - ***** -31415926535897932384-*****
```

### Explanation of Contents

- |  |  |
|--|--|
| (1) Low Toner Message (Fixed)                        | “MACHINE IS RUNNING OUT OF TONER”              |
| (2) Customer ID                                      | Up to 16 characters (User Identification Code) |
| (3) Fax ROM Version                                  |  |
| (4) Transmission / Reception / Copy / Print Counters |  |

## 5.1.9. Service Mode 9 (System Maintenance)

### 5.1.9.1. Overview

This Service Mode is used to maintain and/or update the firmware of the machine. Use the following procedure for System Maintenance.

Service Mode 9		
Step	Operation or Unit Condition	LCD Display
1	Standby	MMM-dd-yyyy 15:00 00%
2	Press "FUNCTION" and then "7".	SET MODE (1-6) ENTER NO. OR V Λ
3	Press "MONITOR" four times, then press "*".	SERVICE MODE ENTER NO. OR V Λ
4	Press "9".	SYSTEM MAINT. (1-8) 1:FIRMWARE UPDATE
5	Press "START" to update the firmware. Enter No. or press "V" or "Λ" to select the maintenance to be performed. Ex: Enter "2".	SYSTEM MAINT. (1-8) 2:FIRMWARE BACKUP
6	Press "SET" and "START".	FIRMWARE BACKUP * IN PROGRESS *
7	After the backup is completed, repeat step 4 through 6 to request an operation.	SERVICE MODE ENTER NO. OR V Λ
8	Press "STOP" twice to return to standby.	MMM-dd-yyyy 15:00 00%

### System Maintenance Table

No.	Maintenance Mode	Description
1	FIRMWARE UPDATE (UF-590/790/6000/ 6100)	1:Card → Host Updates the firmware in the machine with the Master Firmware Card. 2:PC → Host Updates the firmware in the machine with the Master Firmware from the PC. After the firmware is updated, the machine reboots automatically and returns to standby. See Note 1.
	FIRMWARE UPDATE (UF-580/780/5100)	Card → Host (No Selection) Updates the firmware in the machine with the Master Firmware Card.
2	FIRMWARE BACKUP	Creates a Backup Card of the machine's firmware. (A 2 MB or higher Flash Memory Card is required) See Note 2.
3	PARAMETER RESTORE	Restores the parameters from the Backup Card into the machine.
4	PARAMETER BACKUP	Creates a Backup Card of the machine's parameters. (A 1 MB or higher Flash Memory Card is required) See Note 2.
5	PC → FLASH CARD (UF-590/790/6000/ 6100)	Creates a Master Firmware Card using the Firmware Update Tool. (A 2 MB or higher Flash Memory Card is required)
	ERASE FLASH CARD (UF-580/780/5100)	Erases the Firmware from the Card.
8	SEND RECEIVED FILE	Transfers documents from memory to another fax machine during a fatal printer error.

**Note:**

1. For a UF-790 with Firmware V1.04 and updating the Firmware to V2.xx, please see Section 3.4.6 for Instructions.
2. The created Backup Card must be removed from the machine.

## 5.1.9.2. Operation

### UF-590/790/6000/6100

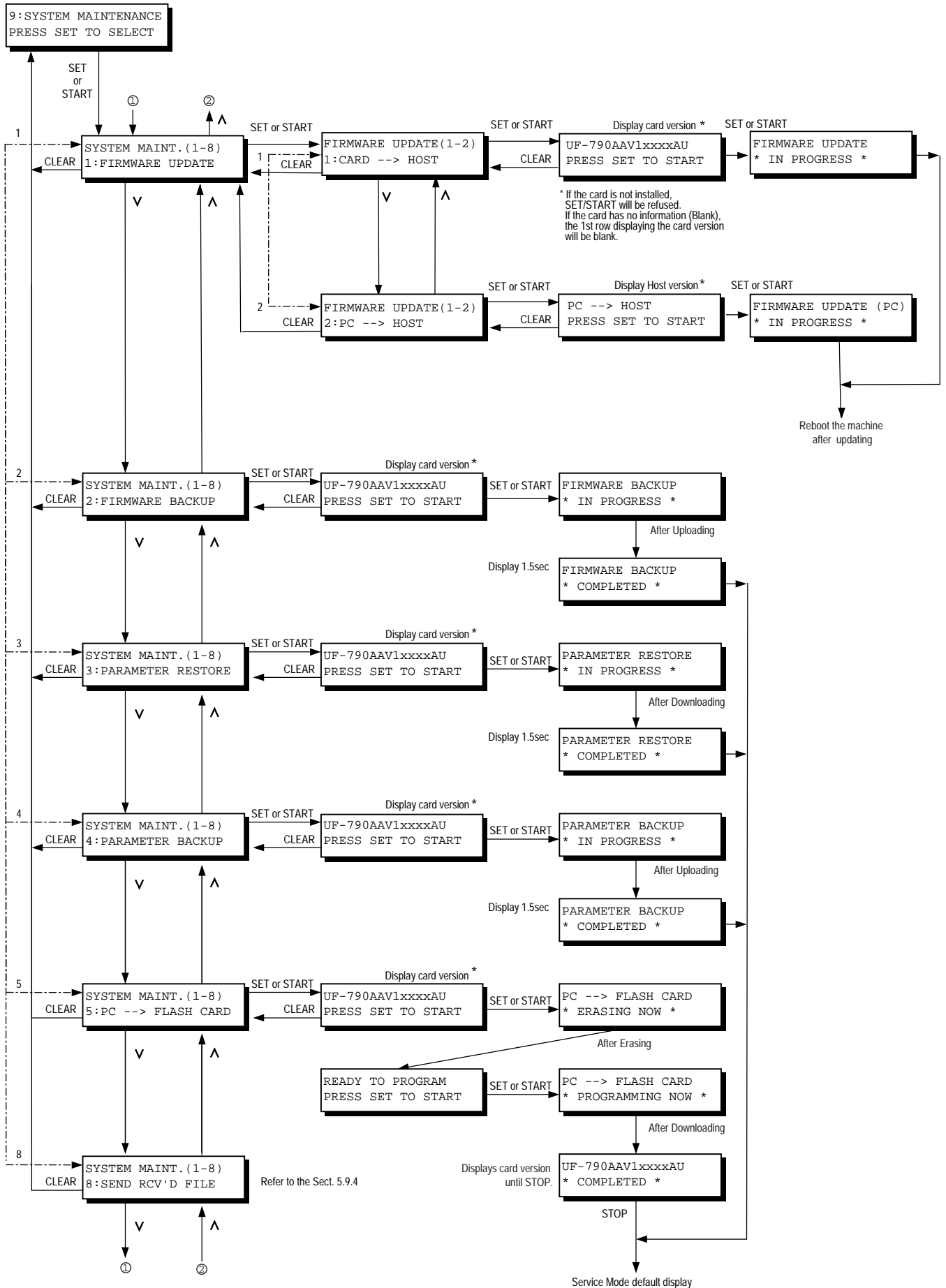

# UF-580/780/5100

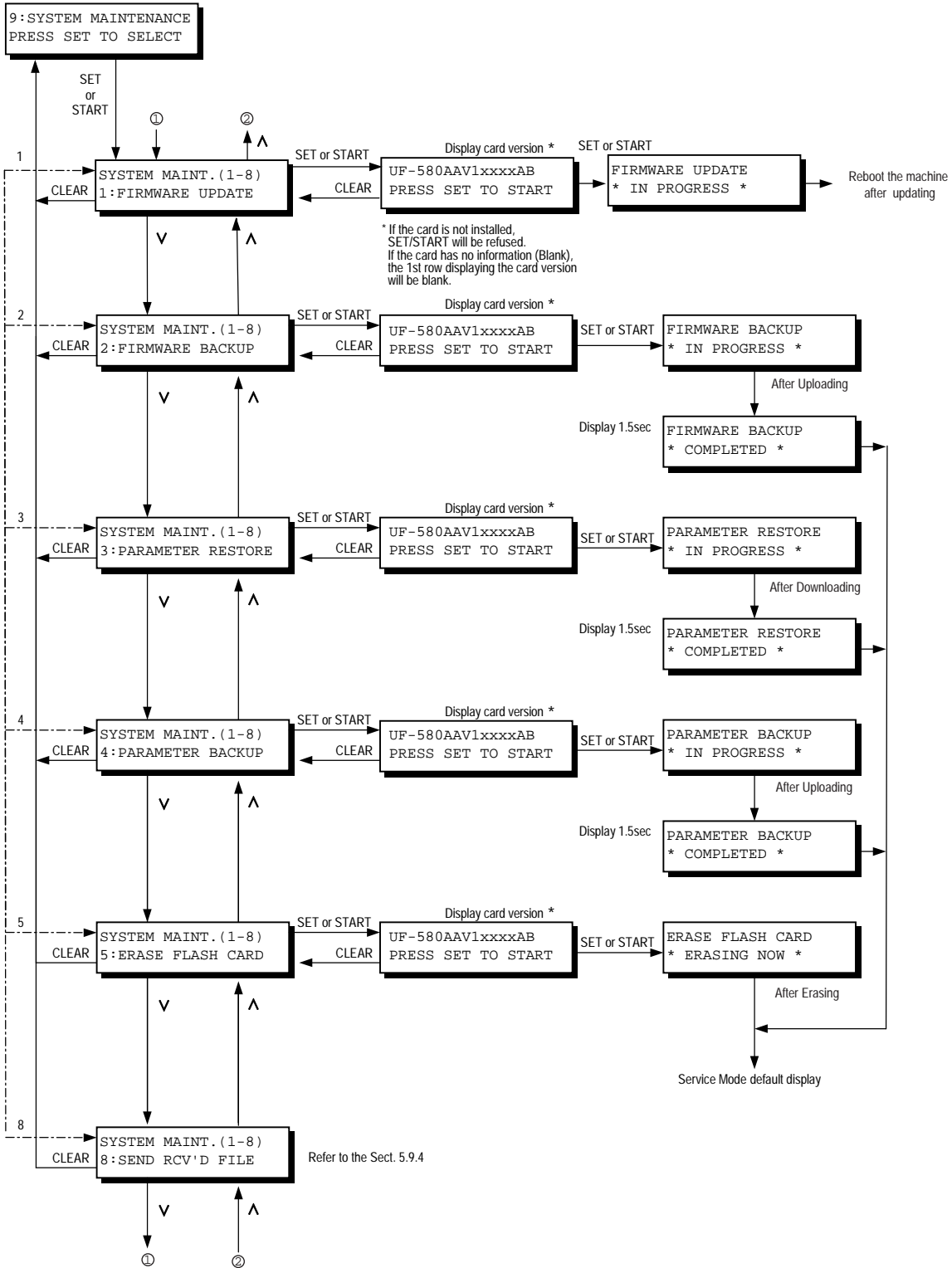

### 5.1.10. Recovering from a Firmware Update Failure

If the Firmware Update is interrupted before completion, the machine will not be able to progress into the Standby Mode and the LCD display will remain Blank. If this happens, please follow the steps described below to recover from a failed firmware update.

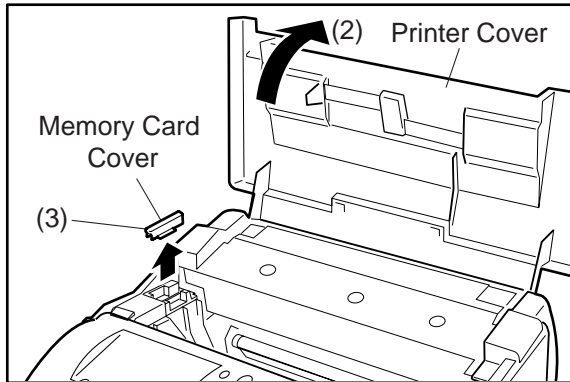

- (1) Unplug the Power Cord.
- (2) Open the Printer Cover.
- (3) Remove the Memory Card Cover.

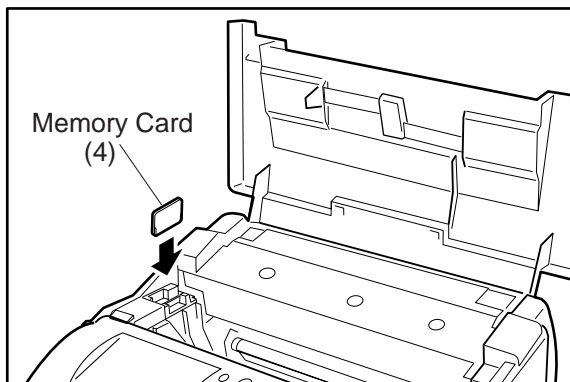

- (4) Insert the Flash Memory Card gently into the card slot with the Panasonic logo facing to the outside of the machine.

**Caution:**  
Installing the Flash Memory Card in the wrong direction may damage the connecting pins inside the machine.

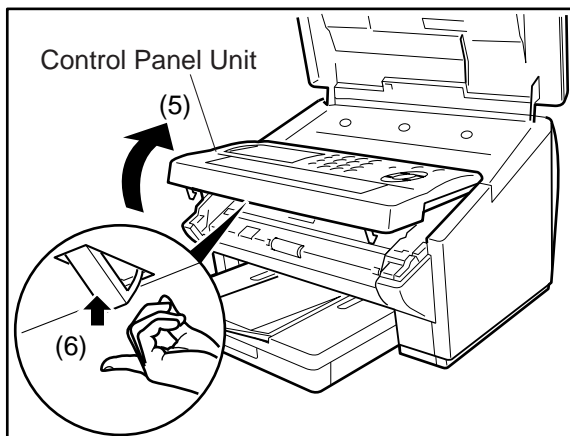

- (5) Open the Control Panel Unit.
- (6) Activate the Read Point Sensor with your finger and plug in the Power Cord.
- (7) Wait approximately 10 seconds, release the Read Point Sensor, close the Control Panel Unit (ADF) and the Printer Cover.
- (8) Allow the unit to complete the Firmware Update (approx. 1-minute). When completed, the unit will reboot and progress to the Standby Mode.
- (9) Unplug the Power Cord.
- (10) Remove the Flash Memory Card.
- (11) Re-install the Memory Card Cover.
- (12) Plug in the Power Cord.
- (13) Perform Parameter Initialization.

**Note:**

- For updating the Firmware directly through the Parallel Port, please refer to the Firmware Update Tool (Parallel) Operating Instructions.
- For Updating the Firmware Remotely through the Phone Line, please refer to the Firmware Update Tool (Remote) Operating Instructions.

Please inform to the Customer prior to proceeding with the Remote Firmware Update, to Never Unplug the Power Cord. If the machine is turned OFF during the Remote Firmware Update, it may not be re-coverable at all. During the Remote Firmware Update, the LCD display shows ON LINE \* DIAG

\*





# 6 System Description

## 6.1. Mechanical Operation

### 6.1.1. Transmit Mechanism

The Transmit Mechanism consists of components which feed, scan and eject documents, as well as send signals. These components and their functions are as follows:

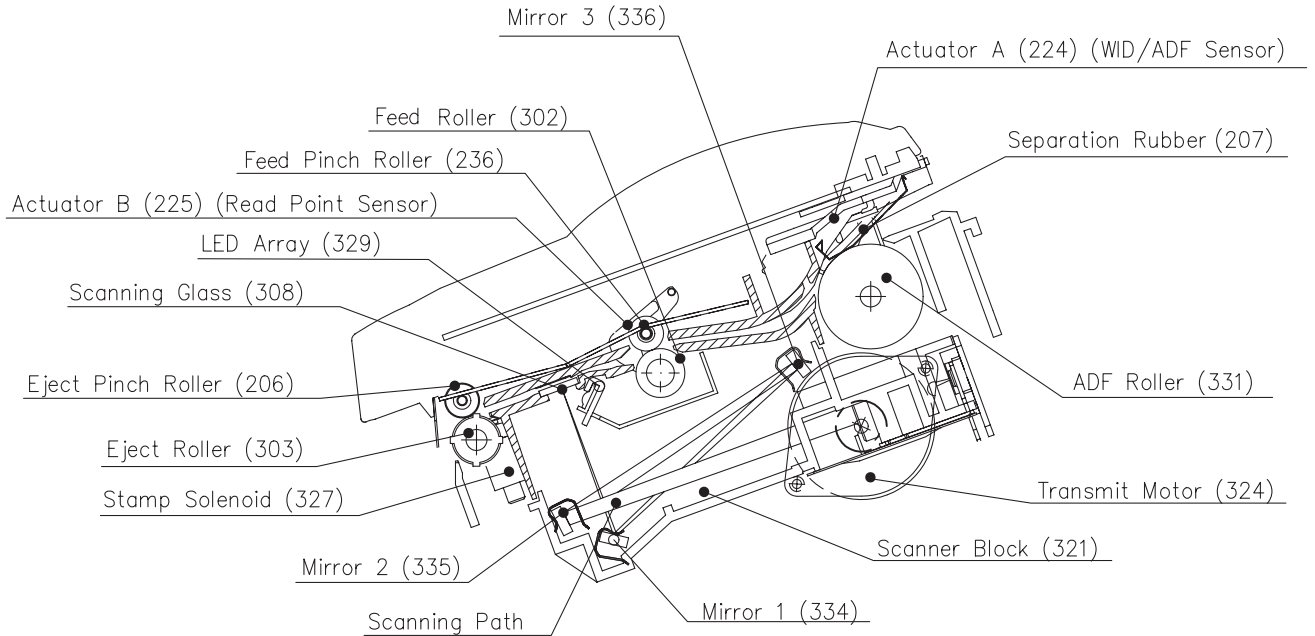

### ADF Mechanism

The ADF (Automatic Document Feeder) automatically feeds paper into the unit, and consists of ADF Roller and Separation Rubber. Each document is placed face-down on the **Printer Cover** (106) before being fed into the unit.

- The **ADF Roller** (331) feeds individual pages into the scanning area.
- The **Separation Rubber** (207) separates documents placed on the ADF, preventing multiple feeding.

### LED Array (329)

The machine has one LED Array, used as a light source to illuminate the document. The LED Array turns ON when the Read Point Sensor is activated by the document leading edge.

### Transmit Guide Unit

The Transmit Guide Unit is an auxiliary part used for feeding and ejecting documents. It consists of the **Transmit Guide** (301), **Control Panel Chassis** (201), **Feed Roller** (302), **Eject Roller** (303), and **Eject Pinch Roller** (206) and **Feed Pinch Roller** (236). This unit also provides the white scanning area and serves as a base for electronic white reference.

### Transmit Mechanism Drive System

This system feeds documents through the transmitting mechanism, and consists of rollers, gears and a stepper motor.

- The **Transmit Motor** (324), a stepper motor, controlled by the CPU, drives the ADF Roller, Feed Roller and Eject Roller, with the speed based on the density of the picture information.
- The **Feed Roller** (302) feeds the document to the scanning point.
- The **Eject Roller** (303) feeds and ejects the document out of the machine.

## Transmit Mechanism Sensors

The **ADF Sensor** (PC1), activated by **Actuator A** (224), detects the presence of documents on the ADF Tray and multiple pages.

The **RP (Read Point) Sensor** (PC3), activated by **Actuator B** (225), detects the lead and trail edges of the document, controlling the reading position. The CPU determines that a document is jammed if Actuator B is not tripped within a specified time after the ADF Roller starts feeding, and disengages the ADF Roller by reversing the Transmit Motor direction.

The **ADF Door Sensor** (PC2), activated by **ADF Door Actuator** (226), halts all scanning operations when the Control Panel Unit is opened.

## Verification Stamp Unit

The Verification Stamp Unit stamps an “X” mark on the front of the document after the document is successfully transmitted or stored. It consists of the **Stamp Head** (325), **Stamp Holder** (326) and **Stamp Solenoid** (327).

## Scanner Block (321)

The Scanner Block consists of three mirrors, a **Lens**, and a **CCD PC Board** (1014).

- The mirrors, **Mirror 1** (334), **Mirror 2** (335) and **Mirror 3** (336) reflect image information, in the form of light, through the Lens.
- The **Lens** focuses the image information and passes it to the CCD.
- The **CCD**, mounted on the CCD PC Board, converts the image information into an electronic signal.

## Drive System

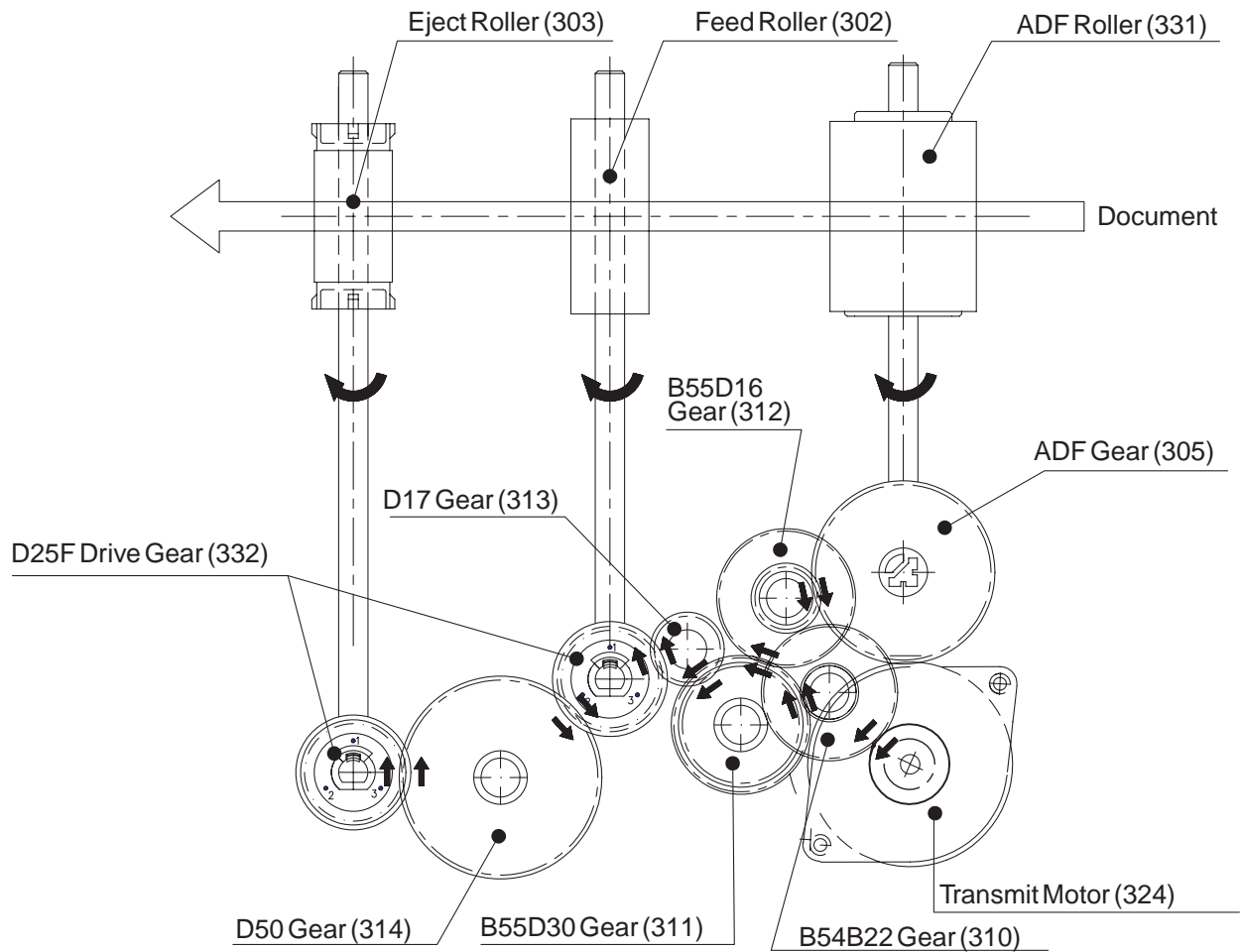

### 6.1.2 Control Panel

The Control Panel consists of the **PNL PC Board** (1004) and **LCD Unit**, which displays the various status messages, and a membrane-type panel.

### 6.1.3. Printing Mechanism

The Receive Mechanism consists of the Laser Unit (LSU), OPC (Organic Photo Conductor) Drum, and various other parts which ensure the normal feeding of recording paper. These components and their functions are as follows:

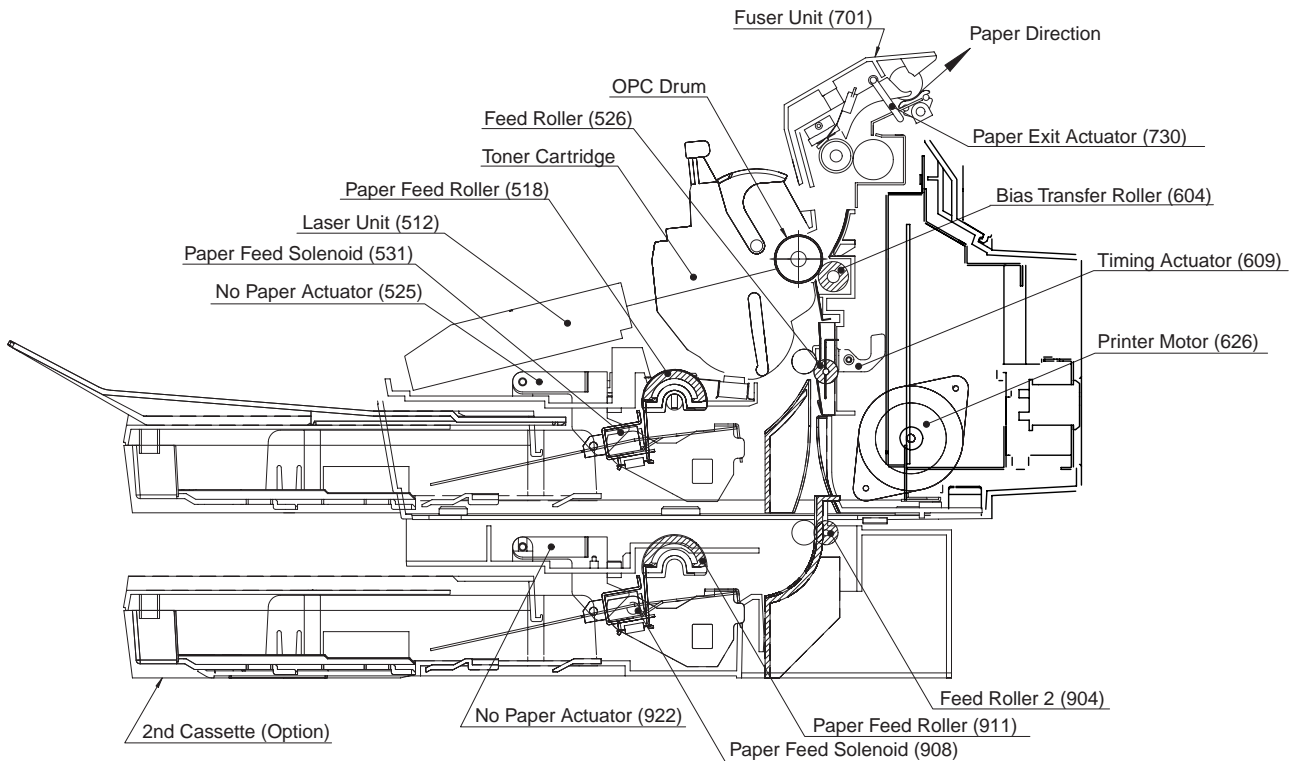

#### Paper Feed Units No.1 and 2

The Paper Feeder Unit No. 2 is available as an option.

#### Paper Feed Unit No.1 Operation

1. The printing operation begins when the nPRNT (Print Request) output signal level goes Low. The **Printer Motor (626)** is initialized.
2. The **Paper Feed Solenoid (531)** is energized for a specified period of time and turned ON. This activates the **Paper Feed Roller (518)**, which rotates one revolution. The paper is separated into individual sheets by the **L and R Paper Separation Clips (809 and 811)** and transported to the **Feed Roller (526)**.
3. After one revolution the **Paper Feed Roller (518)** stops, releasing the paper. The **Feed Roller (526)** transports the paper to the drum area.
4. The actual printing process starts at a specified time after the **Timing Actuator (609)** is activated and stops at a specified period of time after the trailing edge clears the **Timing Actuator (609)**.

## Paper Feed Unit No. 2 (Optional) Operation

The Paper Feed Unit No.1 always takes priority. The Paper Feed Unit No. 2 becomes operational only when the cassette No.1 runs out of paper and the NP Sensor is deactivated, causing the nPCHK1 output signal level to go High.

1. The printing operation begins when the nPRNT (Print Request) output signal level goes Low. The **Printer Motor** (626) is initialized.
2. The **Paper Feed Solenoid** (908) is energized for a specified period of time and is turned ON. This activates the **Paper Feed Roller** (911), which rotates one revolution. The paper is separated into individual sheets by the **L and R Paper Separation Clips** (809) (811) and transported to the **Feed Roller 2** (904).
3. After one revolution the **Paper Feed Roller** (911) stops, releasing the paper. The **Feed Roller 2** (904) and the **Feed Roller** (526) transports the paper to the drum area.
4. The actual printing process starts at a specified time after the **Timing Actuator** (609) is activated and stops at a specified period of time after the trailing edge clears the **Timing Actuator** (609).

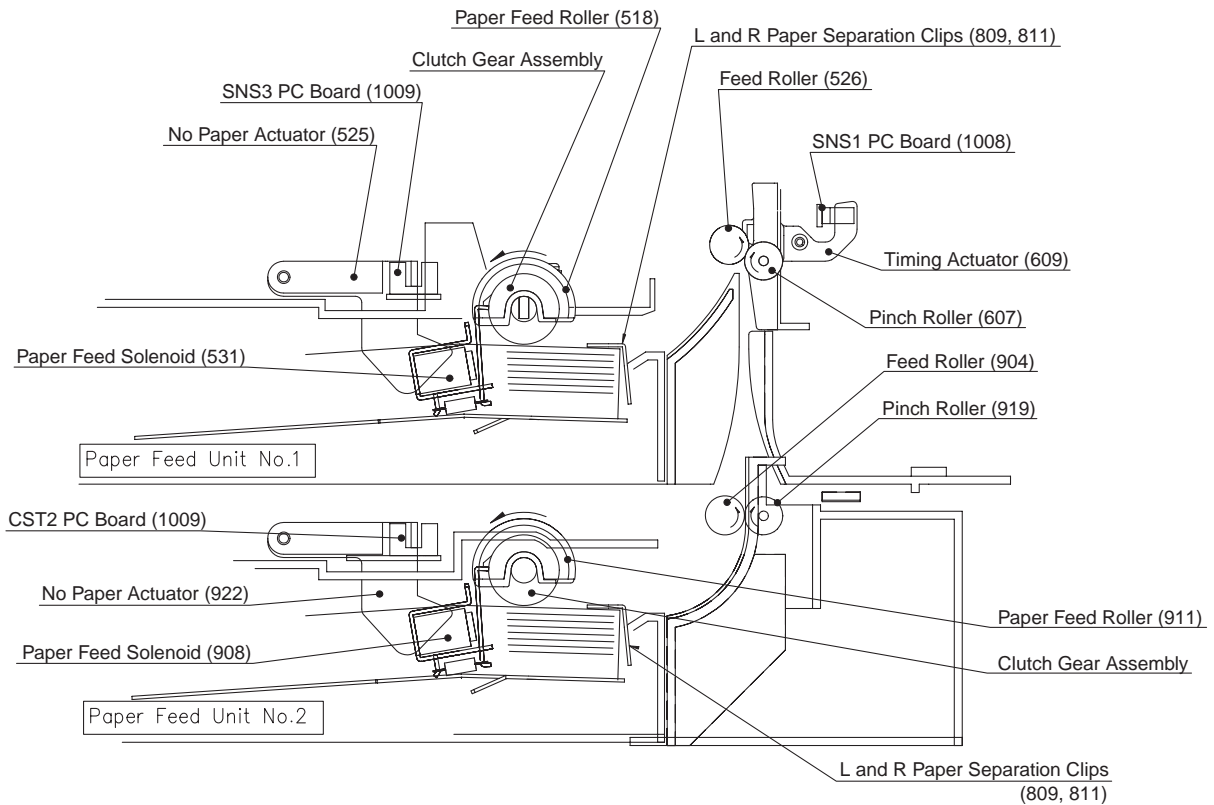

### 6.1.4. Printing Process Operation

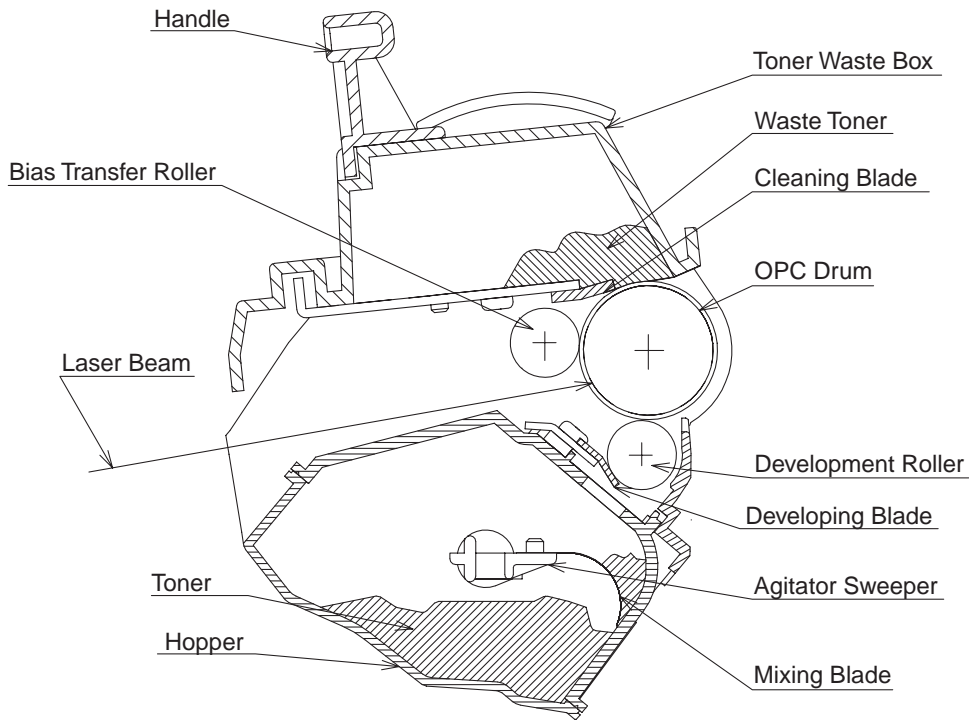

#### Charge

In the dark, the Bias Charge Roller (BCR) applies a high, uniform negative charge to the surface of the OPC Drum. The surface potential is approximately -650 VDC and remains because the drum has a high electric resistance in the dark.

#### Exposure

A portion of the laser beam is deflected to the timing sensor [Beam Detection (BD) Sensor], which controls the start timing of scanning on the OPC Drum. The CPU also uses the timing sensor to detect abnormal signals. The light beam from the laser diode is modulated by the digital signal (nVIDEO) and converted to parallel light waves by the collimator lens. The beam is then directed to the rotating tetragon mirror, where it is reflected to the f- $\theta$  lens and then focused onto the OPC Drum surface. The laser beam moves across the surface of the OPC Drum in the scanning direction. Where the laser beam is applied, the negative charge on the drum dissipates, and where the laser is not applied, the negative charge remains. This action forms a latent, electrostatic image on the OPC Drum, corresponding to the original image.

#### Development

This development process uses a conventional method, where toner coats a Development Roller and transfers to the latent image on the OPC Drum. In the Toner Cartridge, the (mono-component) toner is negatively charged by the friction between the rotating Development Roller (Mag Roller) and the Developing Blade. This combination and the rotation of the Mixing Blade transfers the toner from the reservoir and forms a brush effect on the Mag roller. Where the magnetic brush lightly touches the OPC Drum, the negatively charged toner is attracted to the latent image on the drum, forming a mirror image of the original on the drum. Any remaining toner is removed from the Mag Roller by the Developing Blade and is recycled back into the toner reservoir. A bias voltage of approximately 1.65 kVACp-p at 1.875 kHz, riding on a -300 VDC bias is applied to the magnetic brush to achieve maximum print quality.

The **Toner Sensor** (513), a magnetic sensor, detects the remaining quantity of toner in the Toner Cartridge. When the "TONER" lamp starts to blink, there is still enough toner left in the cartridge to print 100 pages (based on ITU-T Image No.1). When the toner runs out, the display will show: "OUT OF

TONER & INFO CODE 041” and the machine is disabled from printing any copies.

The **Toner Cartridge** consists of OPC Drum, Bias Charge Roller, Development Roller, Developing Blade, Cleaning Blade, Mixing Blades and Toner Waste Box. The **OPC Drum** is an aluminum cylinder coated with an OPC (Organic Photo Conductor) sensitive material. This surface is photoelectric (retains the charge in the dark and releases the charge in the light). The potential differences on the surface (a static latent image) form a printed image. The **Bias Charge Roller** provides a uniform charge on the OPC Drum surface. The **Development Roller** supplies toner to the drum by rotating over the magnet. The **Developing Blade** evens the toner on the Development Roller surface and also charges the toner by friction. The **Cleaning Blade** cleans by scraping the remaining toner off the OPC Drum surface after transfer.

## Transfer and Separation

As the paper is fed between the OPC Drum and the **Bias Transfer Roller (BTR)** (604), a positive charge of approximately  $+3.0 \mu\text{A}$  steady current is applied to the backside of the paper by the BTR. The toner particles are attracted away from the drum towards the surface of the paper. During cleaning, the BTR is charged to approximately  $-1500 \text{ VDC}$  to repel toner on the OPC Drum and prevent toner from being attracted to the BTR. After transfer has occurred, the paper passes over the **Discharge Plate** (612) in the **Transfer Guide** (601), reducing the difference of potential between the OPC Drum and the paper. The stiffness of the paper causes the paper to separate from the drum.

## Cleaning

After transfer, some toner may remain on the surface of the OPC Drum. A Cleaning Blade scrapes the OPC Drum surface, and the removed toner is moved into the Toner Waste Box, inside the Toner Cartridge.

## Laser Unit

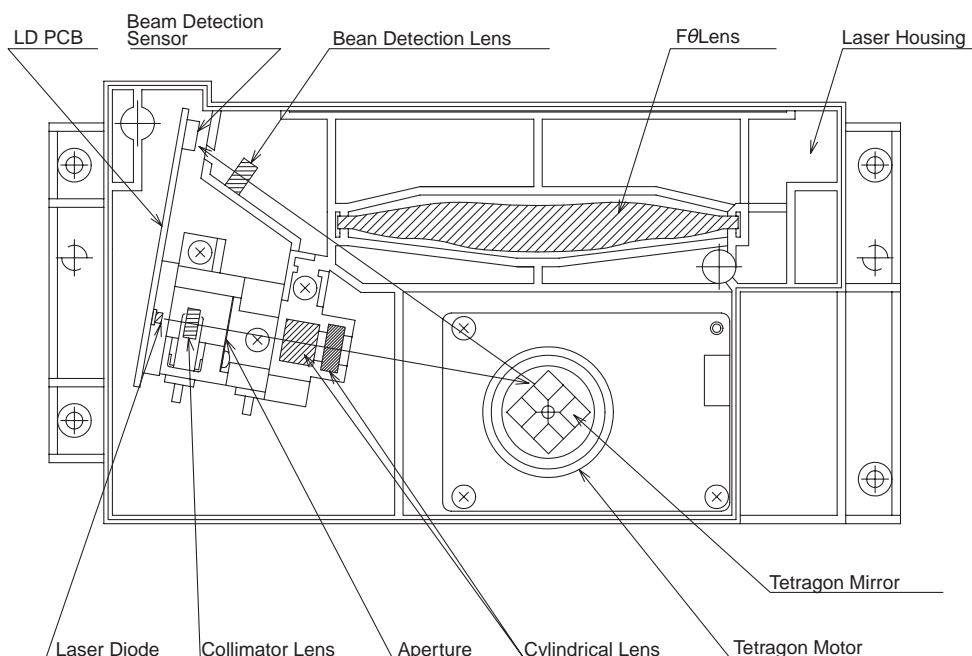

## Laser

A 5 mW Laser Diode, with a wave length of 780 nm ( $\pm 20 \text{ nm}$ ), provides a modulated beam controlled by nVIDEO. The beam power on the drum surface is approximately 0.15 mW, and is controlled by the monitor circuit.

## Collimator Lens

This lens converges and focuses the laser beam, converting it to parallel light.

## Aperture

This controls the size of the laser beam.

## Tetragon Mirror and Motor

The tetragon scanner consists of a 4-sided mirror, directly driven by a tetragon motor, revolving at 8,898 rpm (400 dpi) or 13,347 rpm (600 dpi). Scanning speed for 400 dpi and 600 dpi are controlled by motor clock supplied from SC PCB. Motor clock for 400 dpi is 890 Hz and 600 dpi is 1,335 Hz. The laser beam is reflected against these mirrors and swept over the recorded width in the scanning direction. This unit features a stable line scanning speed, a precision mirror reflection angle, a reflection free surface, and instant start.

## Beam Detection (BD) Lens and Beam Detection (BD) Sensor

The BD Lens receives the reflected light from the Polygon Mirror and redirects it into the BD Sensor, which converts the laser beam into electrical signals and sets the start timing for the scanning line.

## f- $\theta$ Lens

This amorphous plastic, molded lens is designed to provide parallel laser light across the surface of the drum, providing a constant scanning speed.

## Fusing and Paper Exit

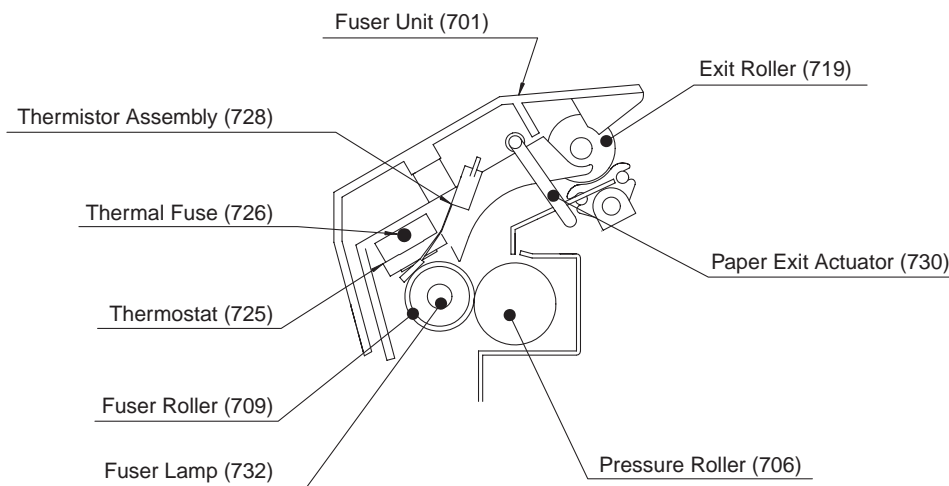

## Fuser Unit (701)

The Fuser Unit, consisting of the Fuser Lamp, Fuser Roller, Pressure Roller, Thermistor, and Thermostat, bonds the toner into the paper using heat and pressure.

## Fuser Lamp (732)

Located in the Fuser Roller is a Halogen lamp that serves as the heat source for the Fuser Roller.

## Fuser Roller (709)

A Teflon coated roller supplies the heat for bonding the toner to the paper. The temperature of the surface is kept constant at approximately 160°C ( $\pm 5^\circ\text{C}$ ) or (320°F).



### **Pressure Roller (706)**

This converted PFA tube Silicon Rubber Roller applies pressure to the Fuser Roller, assisting in bonding the toner to the paper.

### **Thermistor Assembly (728)**

The Thermistor, a heat sensitive resistor, in contact with the Fuser Roller, monitors the surface temperature. The temperature detected is used to control the ON/OFF switching of the Fuser Lamp. It also acts as the primary overheating prevention device. A comparator circuit on the FCB PC Board acts as a secondary overheating protection and becomes active at approximately 185°C (365°F).

### **Thermostat (725)**

A Thermostatic Fuse, part of the power line for the Fuser Lamp, provides an extra overheating protection by opening when the Fuser Roller surface temperature reaches approximately 200°C (392°F) and remains there for 1 minute. If the primary and secondary overheating protection does not halt the rise in temperature, the thermostat opens, removing power from the Fuser Lamp. When the Thermostat opens, it must be replaced.

### **SNS4 PC Board (1007) [Paper Exit Sensor]**

This sensor detects the presence of printed paper at the exit. If no paper passes, or if paper is over the sensor too long, a "RECORDING PAPER JAM" message is displayed. When paper passes over the sensor, the output is Low (Low Active).

### **Thermal Fuse (726)**

It is placed in series with the Thermostat on the power line of the Fuser Lamp and performs the tertiary overheating prevention (in case the Thermostat fails) by opening when the surrounding temperature reaches approximately 216°C (420.8°F).

## **6.1.5 Covers and Enclosures**

The **Printer Cover** (106) contains the **R and L Document Guides** (107 and 108), which adjust to the paper width to properly feed the original documents. The **Left Cover** (103) has a **Speaker** (117) mounted inside and shields the circuit boards. The **Rear Cover** (105) contains the **Recording Paper Tray** (111) and **Recording Paper Sub Tray** (112), used to support legal size documents.

## 6.2. Electrical Circuit Explanation

### 6.2.1. Fax Block Diagram

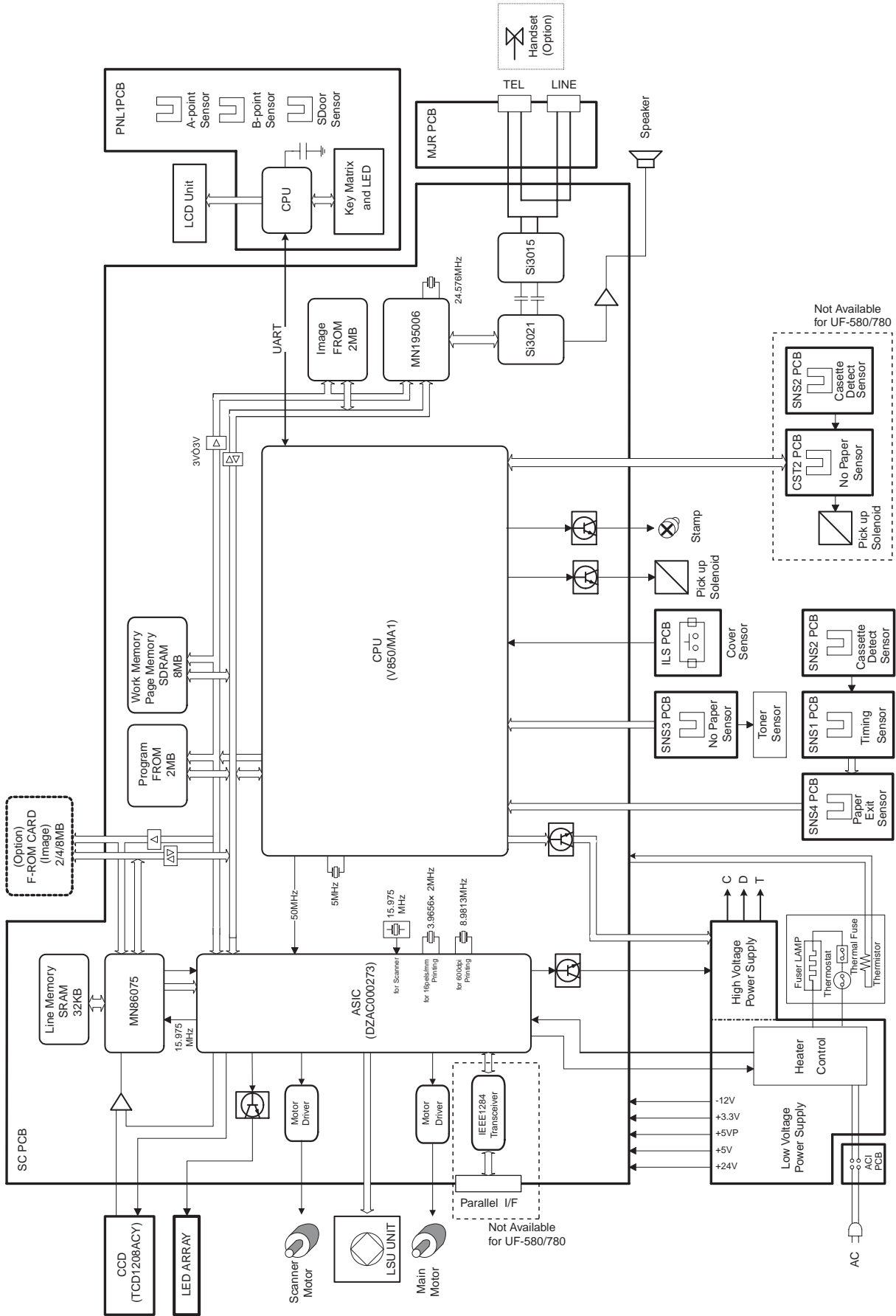

## 6.2.2. Signal Routing

### 1. ADF Transmission

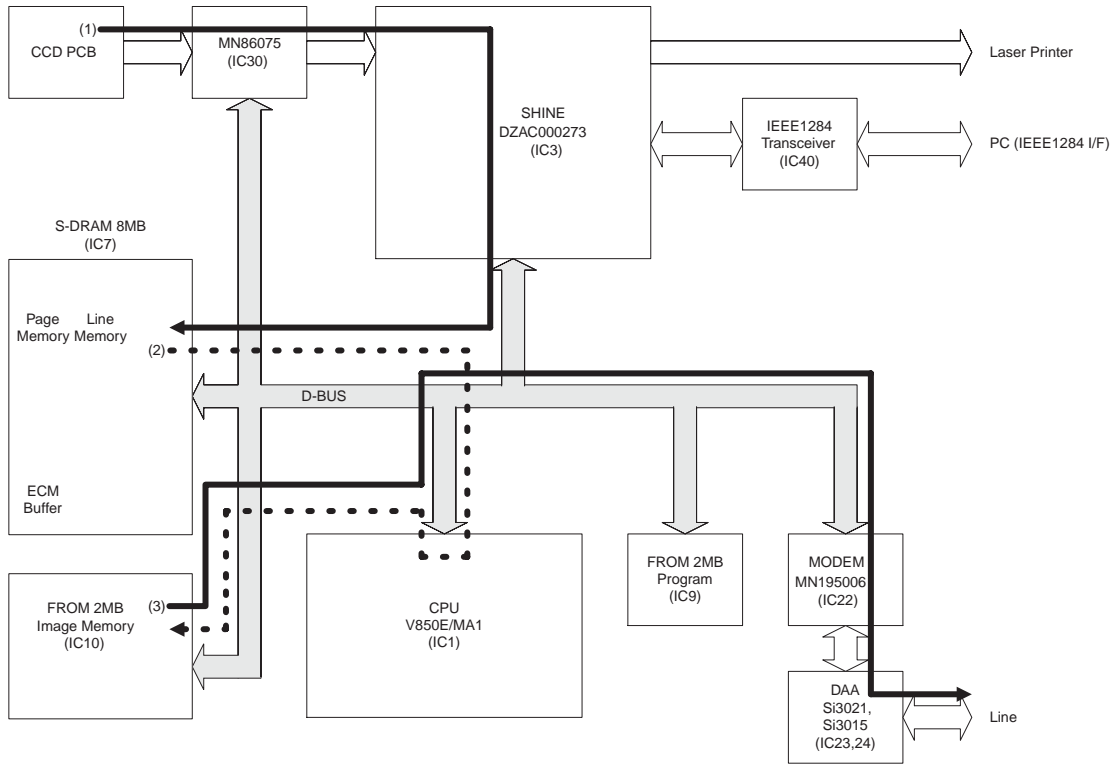

### 2. Memory Transmission

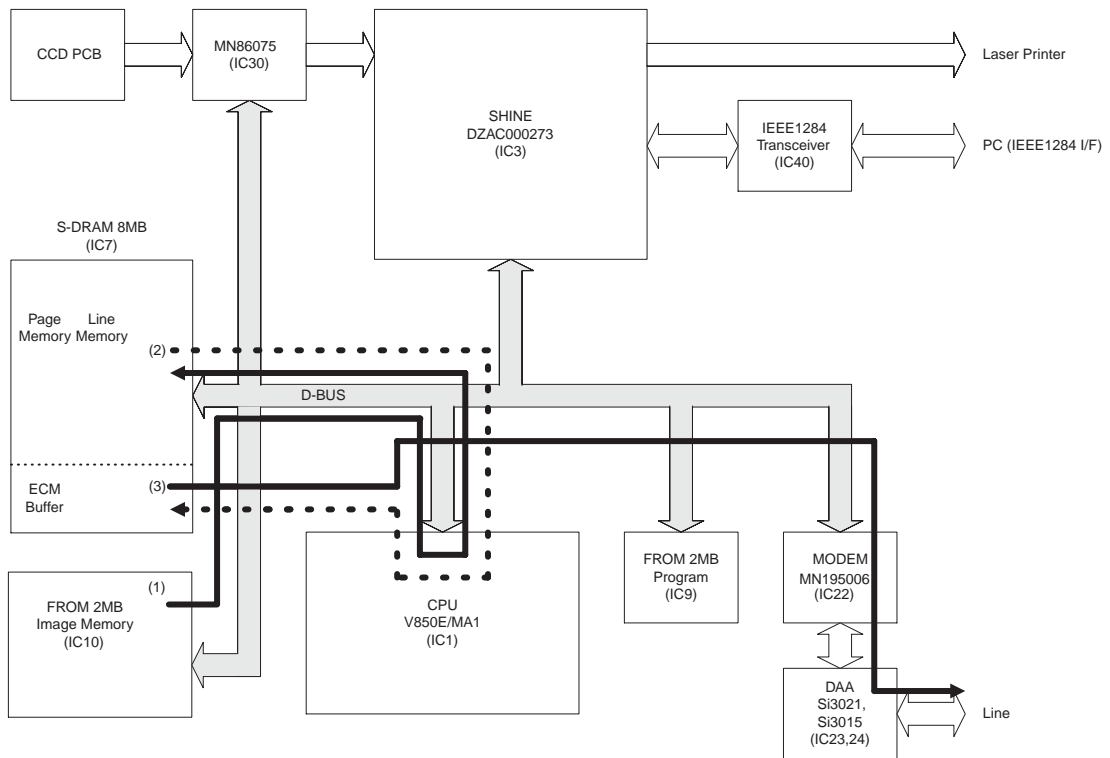

### 3. Direct Reception

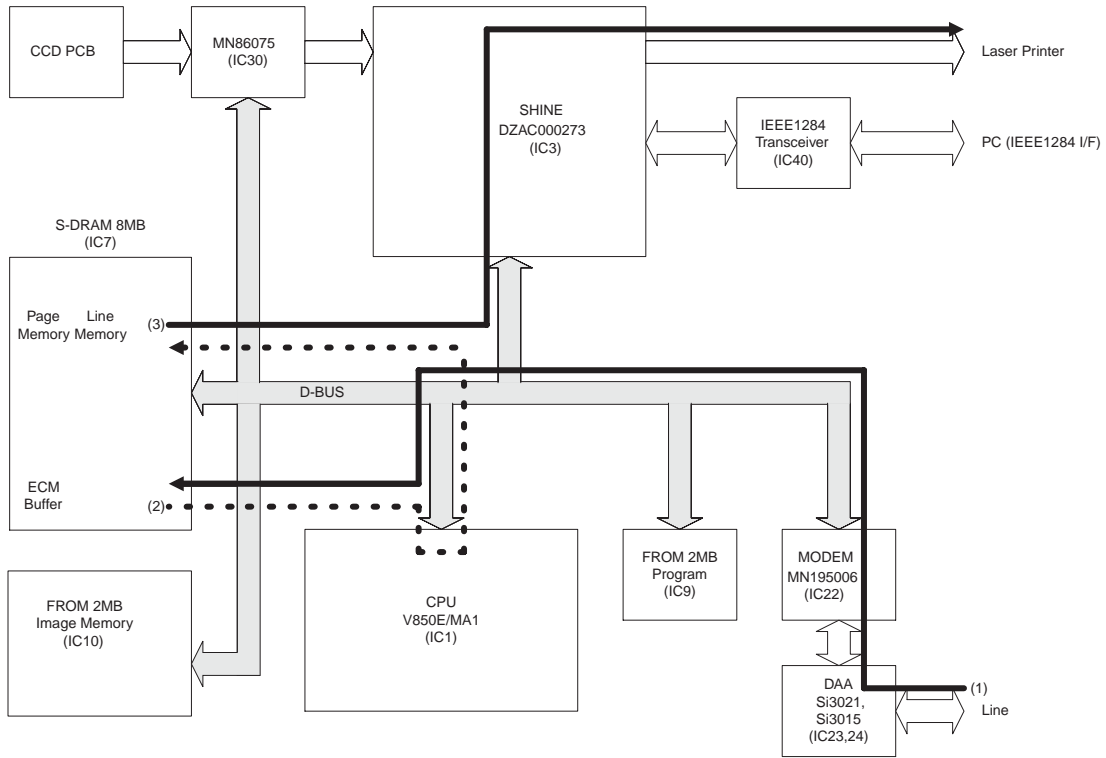

### 4. Memory Reception

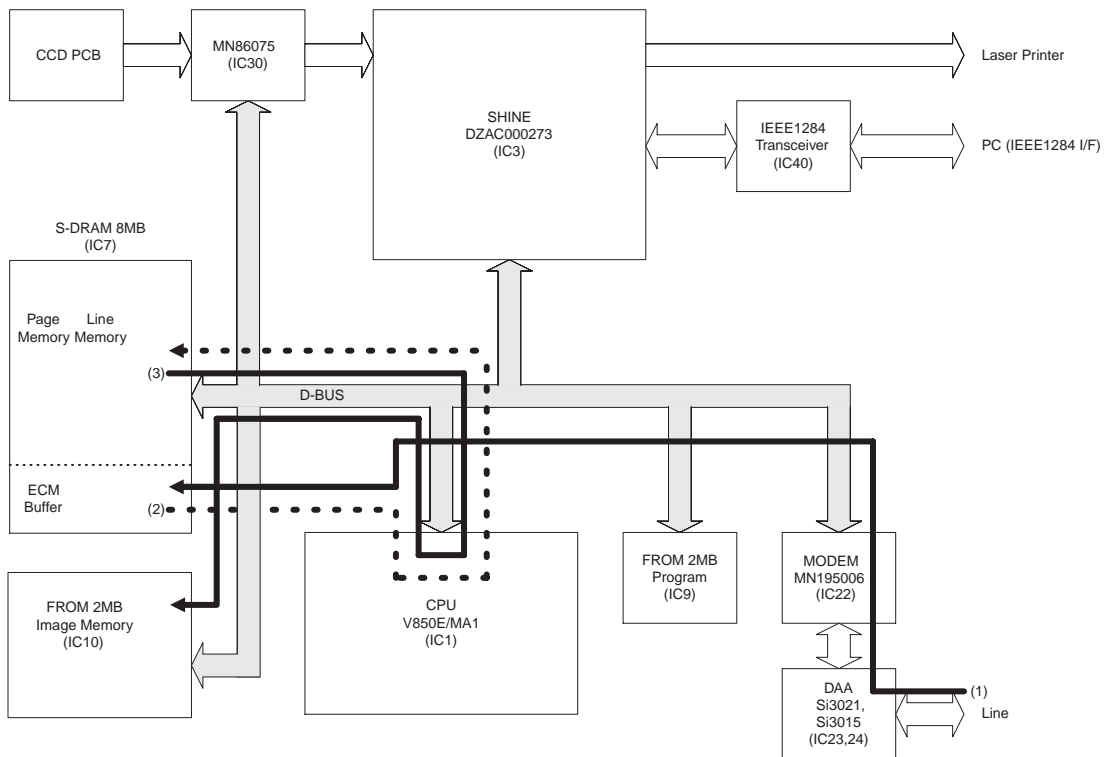

## 5. Scan into Memory

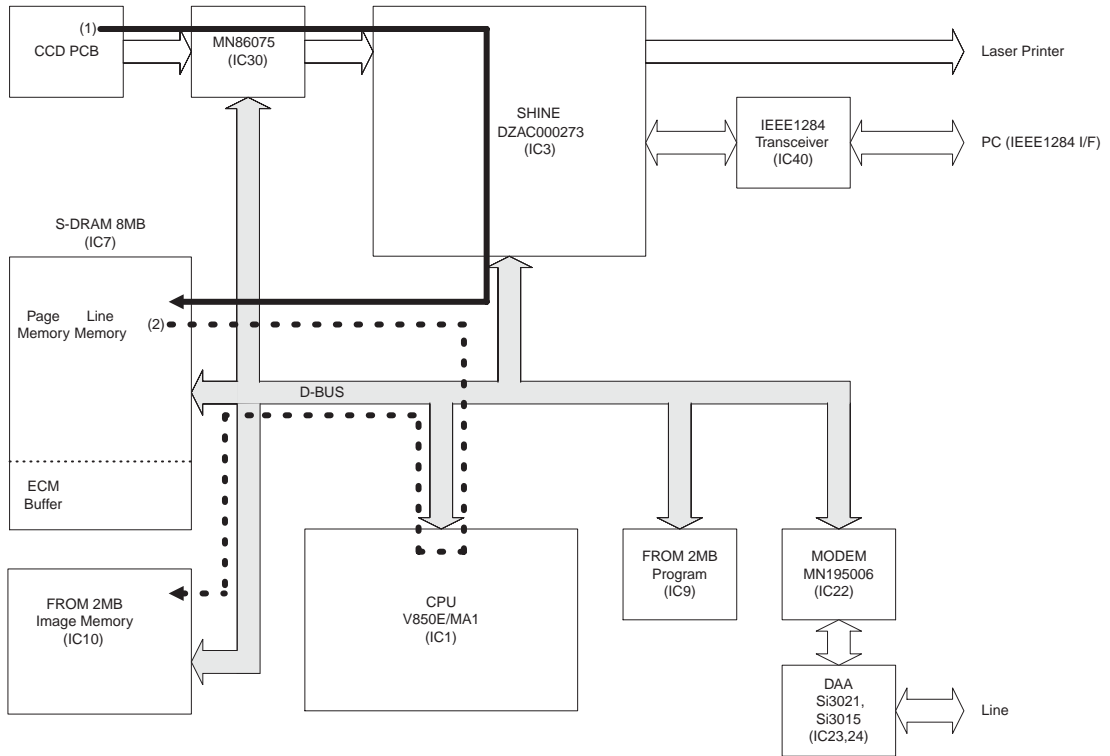

## 6. File Print from Memory

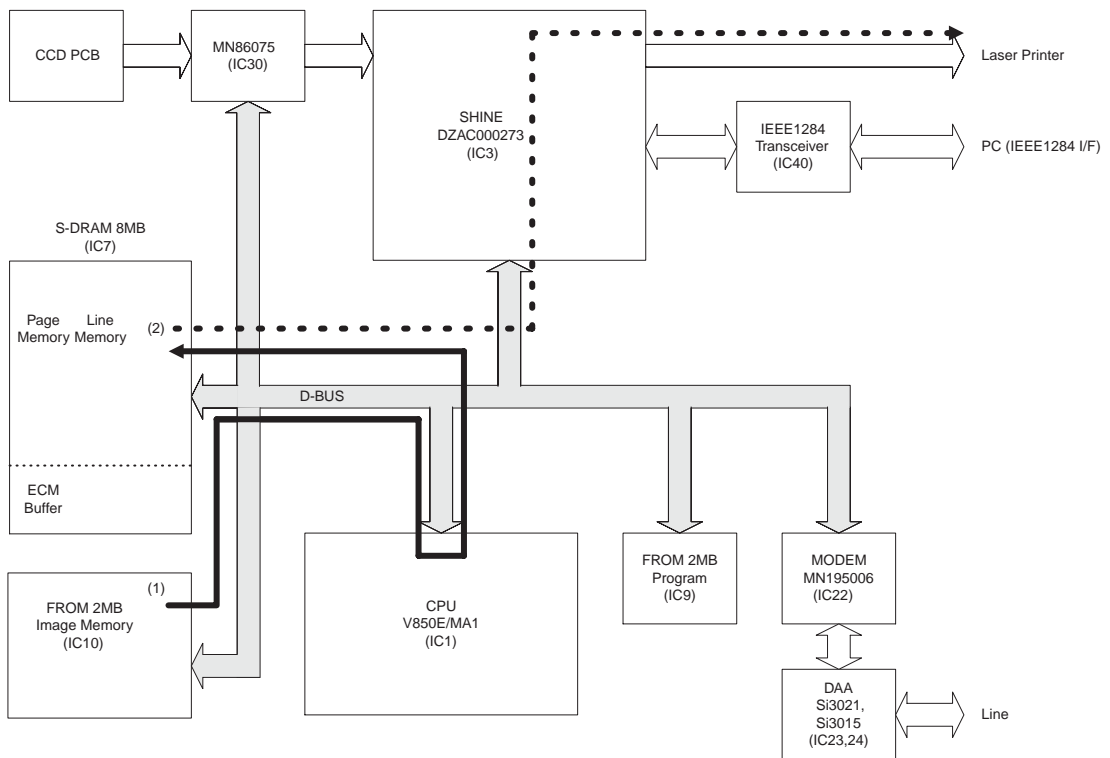

## 7. Single Copy

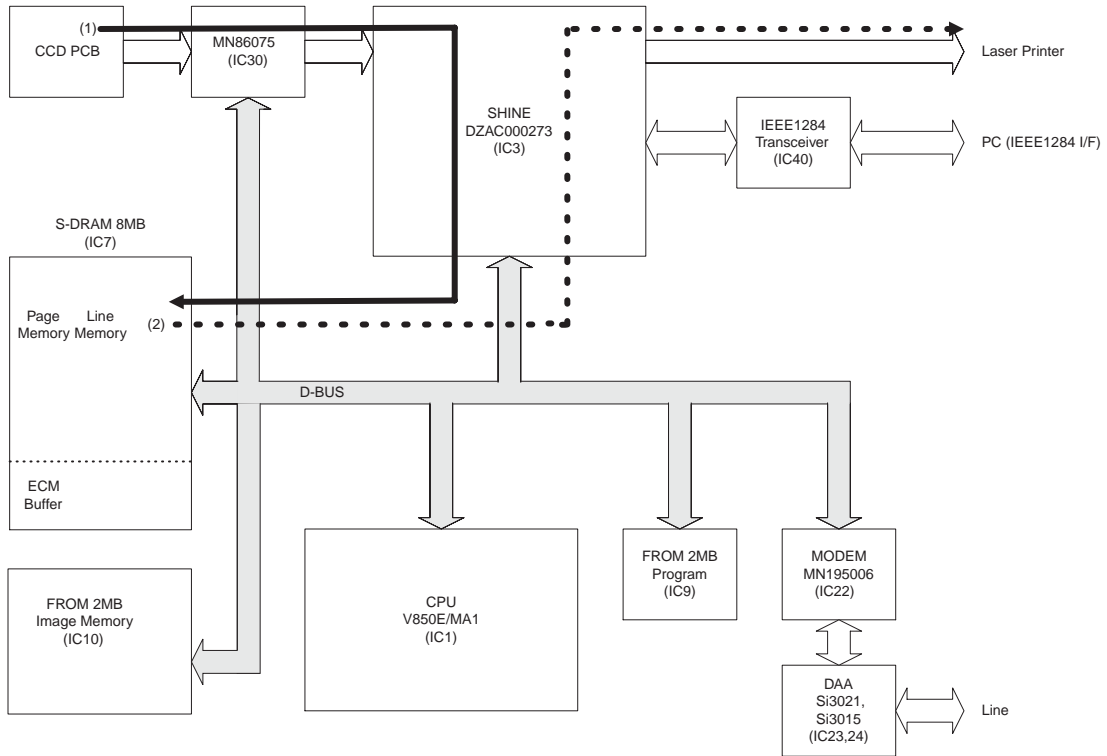

## 8. Multiple Copies

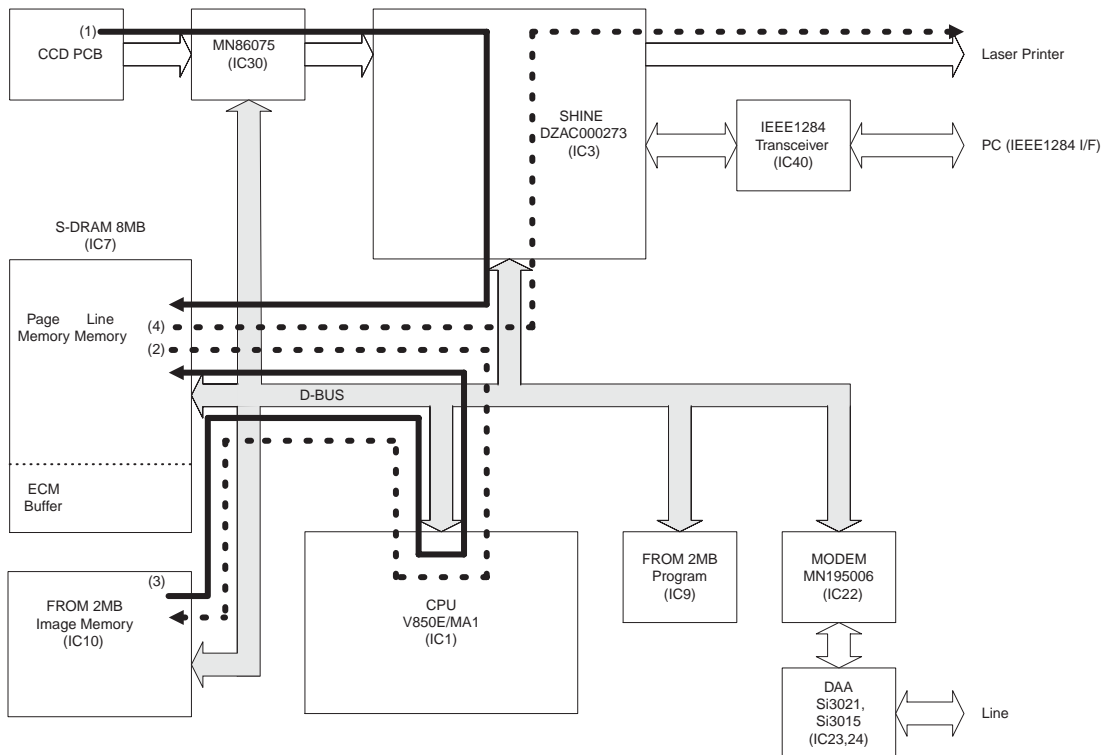

## 9. Report/List Printing

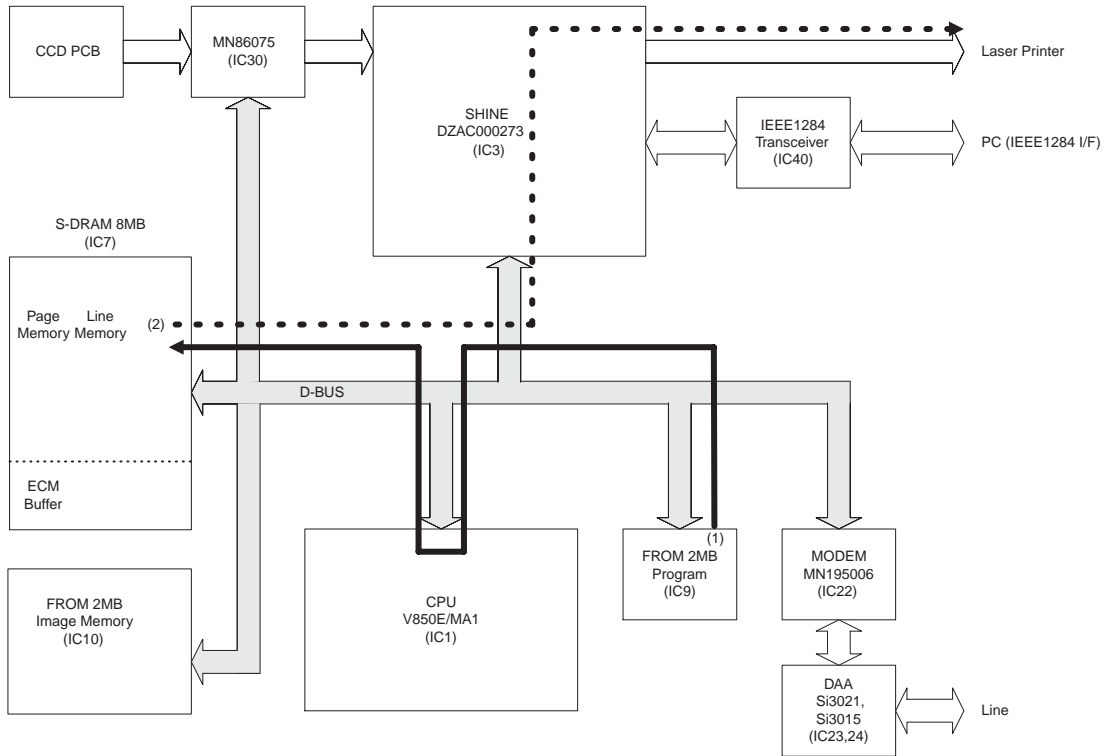

## 10. Report with Image Data

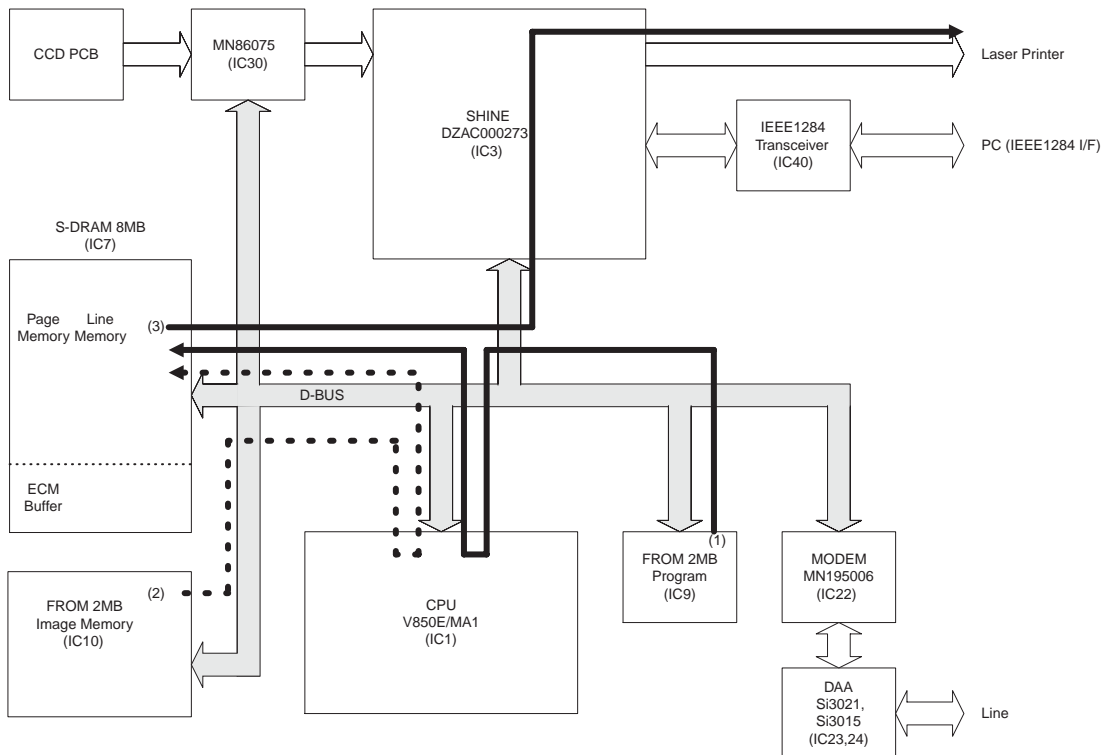





### 6.2.3 Picture Signal Scanning Block

The image data read by the optical unit is input to the CCD mounted on the CCD PC Board, then transferred to the SC PC Board after the optical information is converted into an electrical signal by the CCD. The following shows a block diagram of the picture signal scanning circuit. This picture signal scanning circuit consists of (1) ABC circuit, (2) shading correction circuit, (3) offset control circuit, (4) picture signal binary coding correction circuit and (5) reducing circuit.

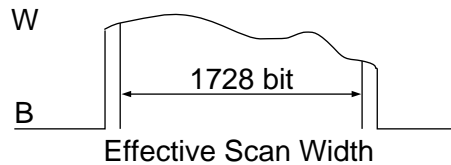
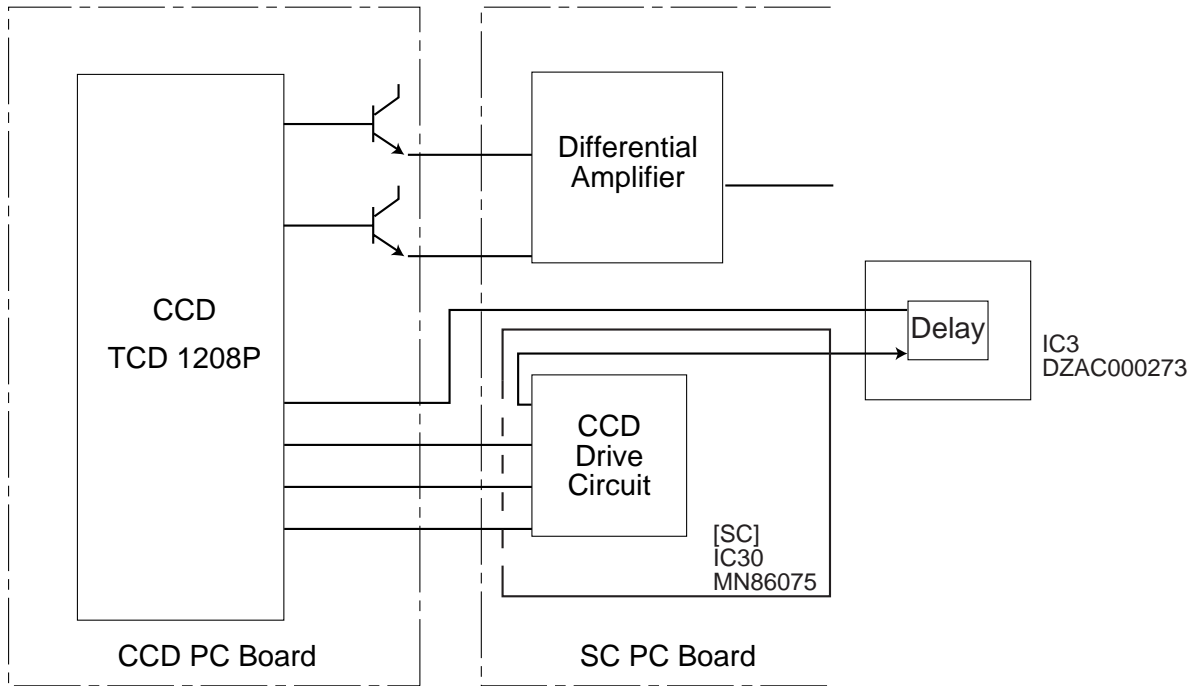

#### ABC Circuit

This circuit consists of IC28, IC30, C175, R288 and R285. Its function is to prevent deterioration of picture quality due to dirt on the document or degrading of the luminous energy of the Xenon Lamp light source. The picture signal from the CCD is amplified in IC28 and input to IC30, where it is converted from analog to digital and the shading is corrected. When the signal exceeds +5V as the result of this amplification and correction, capacitor C175 is charged through R288. This charging voltage lowers the level of the picture signal input to IC28. When the picture signal voltage rises, this charge voltage becomes higher. When the picture signal level lowers due to the background color, etc., of a transmitting document, the voltage of the charged capacitor C175 is discharged through R285. Consequently, the output of the ABC circuit is kept constant to maintain the picture quality, regardless of changes in the CCD output level.

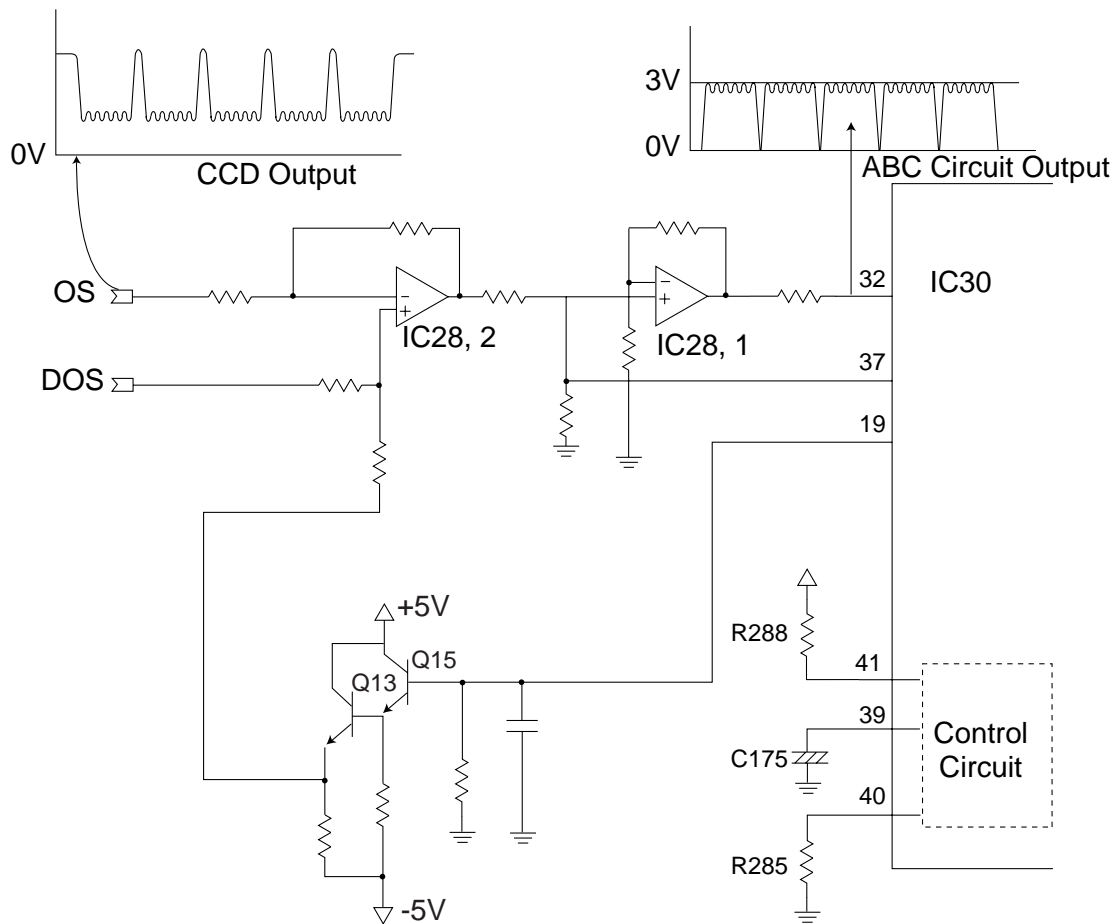

### Shading Correction Circuit

The Shading Correction Circuit, included in IC30, is provided to correct for reduction in LED lamp intensity around the optical lens and LED lamp intensity distortion due to shading of each bit. This circuit scans the white reference on the transmitting document plate immediately before the document reaches the scanning position and writes a compensation value according to the distortion of the waveform, at the time, into the S-RAM (IC31). When the actual picture signal is input, the circuit corrects the picture signal shading, according to this compensation value. This shading is carried out for each page during transmission or copy.

### Offset Control Circuit

The Offset Control Circuit consists of Q15, Q13, IC30 and IC28, and controls the black level of the CCD output to be at 0V by using the input.

### Picture Signal Binary Coding Correction Circuit

The Picture Signal Binary Coding Correction Circuit is included in IC30. It is used to obtain a binary coding signal which is a corrected picture and error diffused signal of a false halftone signal, which is detected from a shaded picture signal.

### 6.2.4 CCD Drive Clock Generator Circuit

This circuit is also contained in IC30. Its function is to generate FSG, FCK1, FCK2 and RS clock signals, which are required for driving the CCD. These clock signals are generated by the system clock generator circuit derived from the 4 MHz clock signal that is input to IC30. Its timing chart is shown below. The FR clock supplied to the CCD is output from the RS of IC3. The RS clock of IC3 is derived from the FR clock of IC30 [MN86075] generates the timing of the RS clock to drive the CCD.

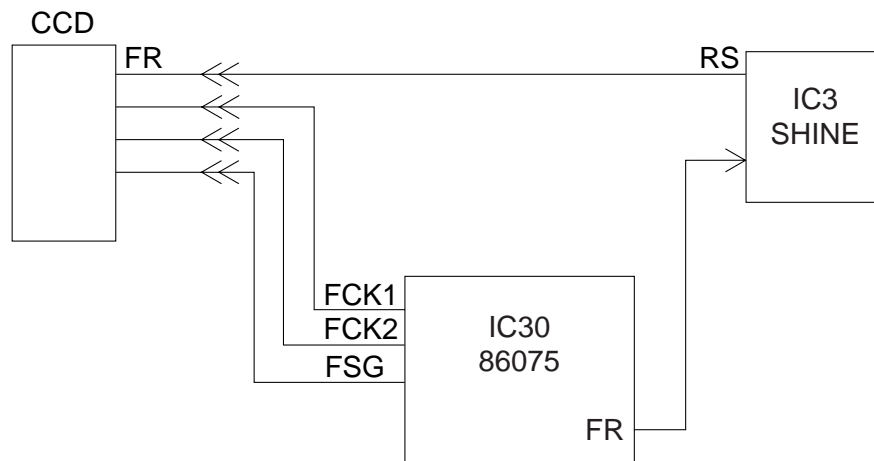
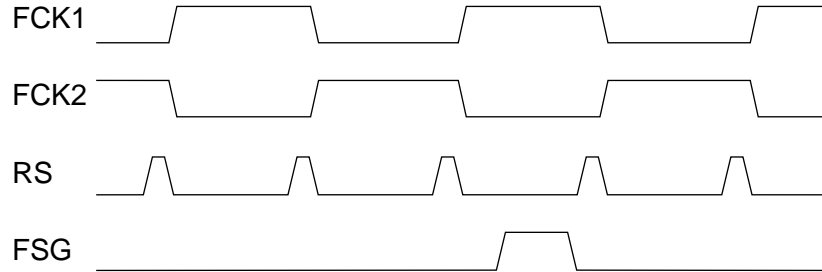

## 6.2.5 Line Monitor Circuit

The Line Monitor Circuit consists of an operational DAA (The secondary side chip) and its peripheral circuits. Its function is to monitor the dial tone, DTMF tone, response signals, etc. over the speaker. It also sounds the output of the key touch tones, alarm tones, etc. from the panel CPU over the speaker. The Received Signals are output from DAA of Secondary circuit, and through Analog AGC, Electronic Volume, Amplifier and over the speaker.

The monitor tone from the phone line and the buzzer tone from the panel can be adjusted from the Control Panel.

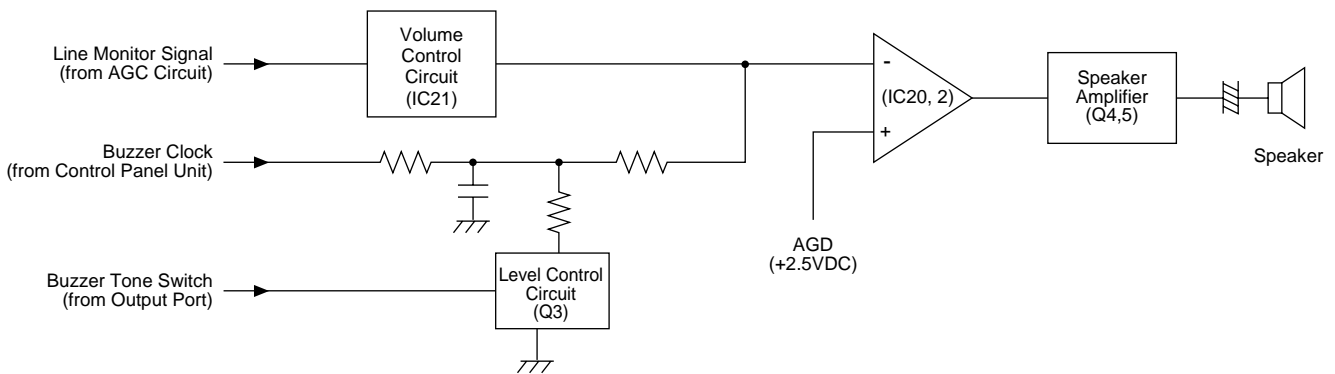

Line Monitor Circuit  
Block Diagram

### 6.2.6 Transmit Motor Control Circuit

The transmit motor is a PM type, two-phase bi-polar motor. The stepping signal and chopping current control signals (pTAPH, pTBPH, pTA10, pTA11, pTB10 and pTB11) are sent to the chopper drive circuit, comprised of IC36, IC37 and its peripheral circuitry, from IC3 SHINE output port. The motor is powered by +24 VDC and is driven by a 1/2-phase excitation, and greater step division is provided by controlling the phase circuit in steps (micro-step control).

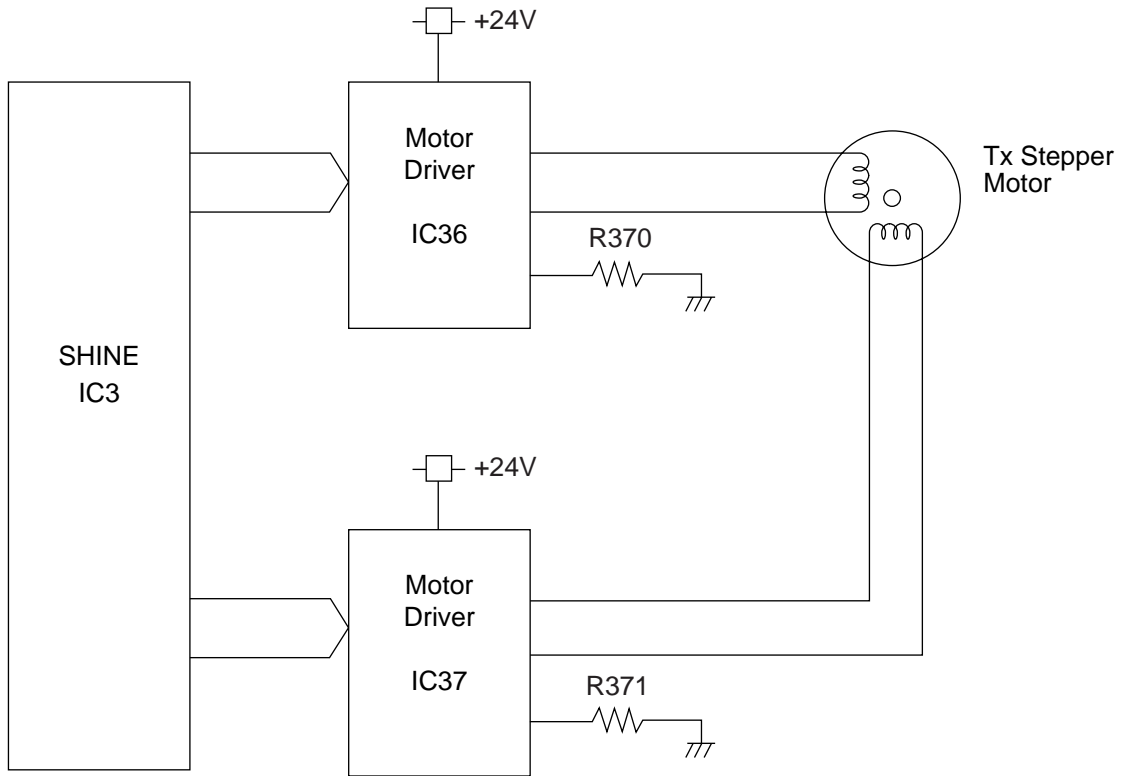

Tx Motor Driver Circuit Block Diagram

## 6.2.7 Line Control Circuit

The Line Control Circuit consists of CML relay, DP circuit, DAA (Direct Access Arrangement), Ring Detect Circuit for power-save and DC hold circuit. A Jack for an external telephone, which can be used for either an external telephone or an optional Handset Kit. The block diagram of the Line Control Circuit is shown below.

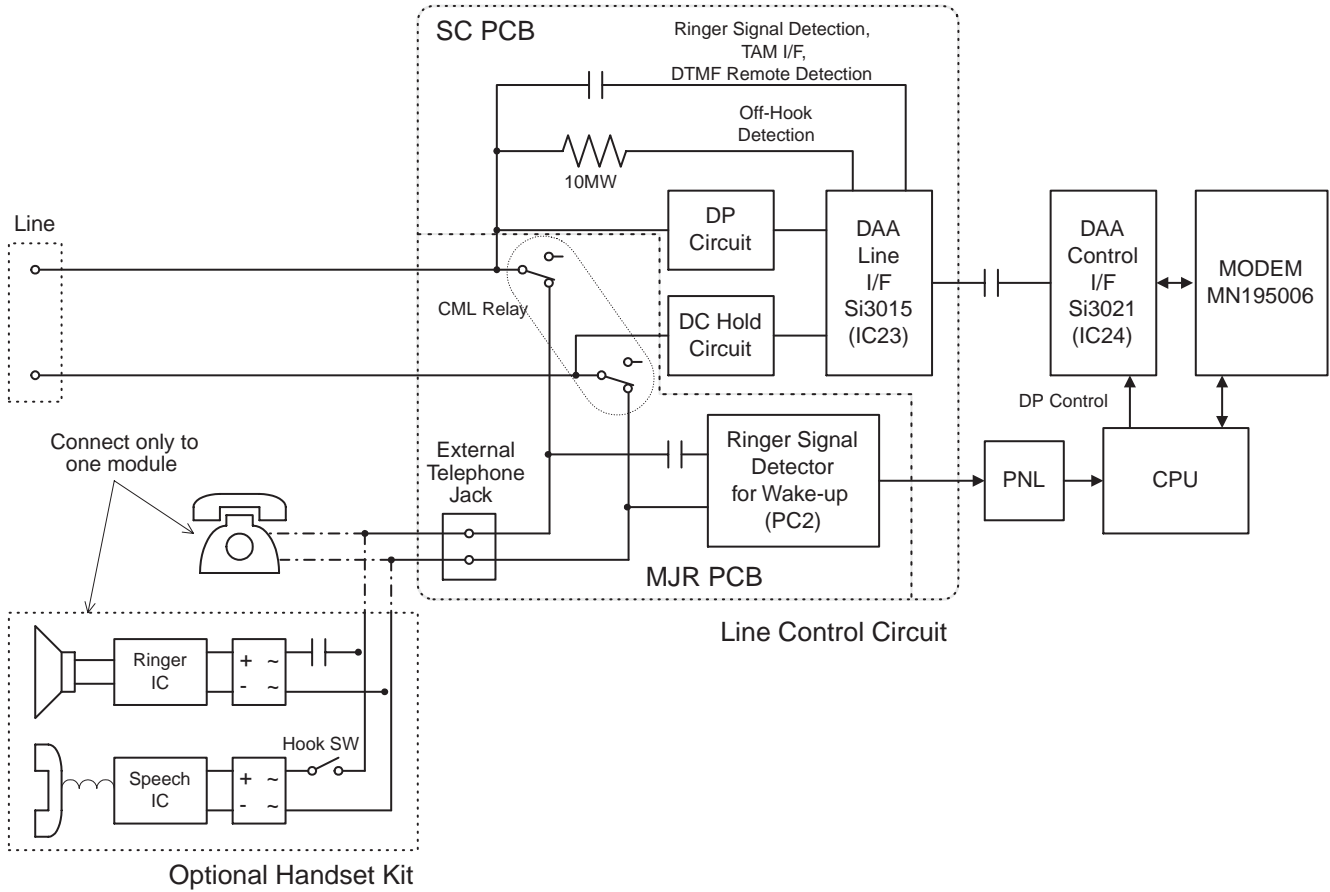

## Dial Pulse Generator

The Dial Pulse Generator consists of a CML relay, a DC hold circuit, a dial pulse generate circuit and their peripheral circuits. The generator generates dial pulses. The CPU on the SC PC Board controls all dial pulse generation sequences. When the absence of the terminating message is confirmed by the Off-Hook detector in DAA(IC23), the CPU turns the CML relay ON and the dial pulse generate circuit ON through DAA to develop loop status (DC loop). After a few seconds, the CPU turns the PLS relay ON and OFF to generate dial pulses, making and breaking the loop. The line status during dialing is shown below.

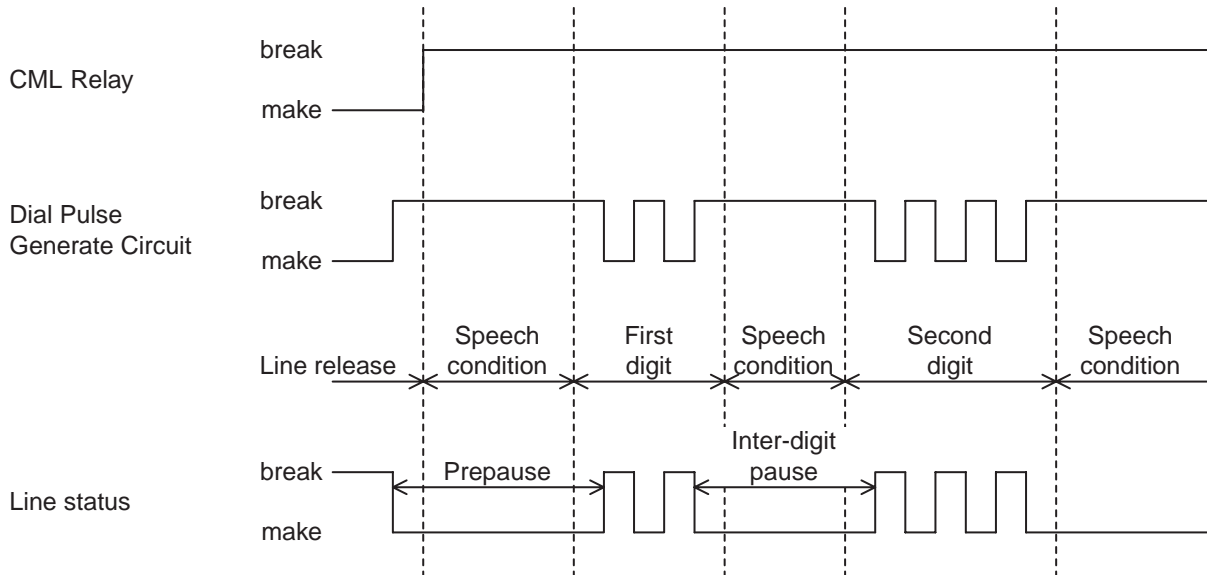

## DTMF Tone Generator

The DTMF Tone Generator is incorporated in the MODEM on the SC PC Board. The DTMF tone is conveyed to the telephone line using the same route as the facsimile signal. The DTMF tone selection is controlled by the CPU. Digital amplitude signal is conveyed as analog amplitude signal through D/A converter in the DAA (IC23). The line status during dialing is shown below.

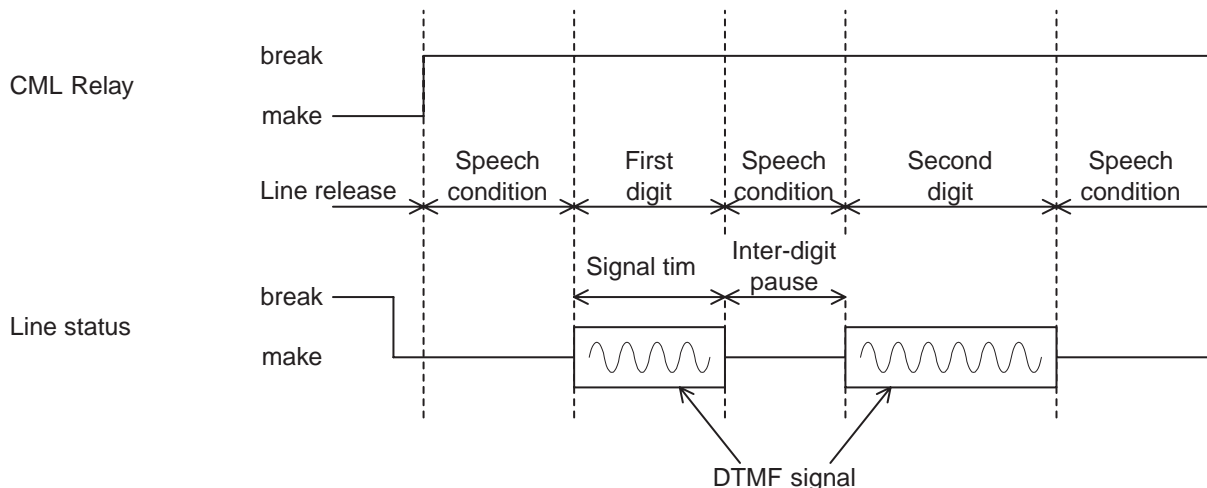

## Ring Detector

When the unit is in the Sleep Mode status, a Ringing signal is detected by a photo-coupler (PC2) in Ring Detector to cancel the power-save for waking up. Then DAA (IC23) detects the ringing signal for receive mode.

When the unit is normal operating status, DAA (IC23) detects the ringing signal immediately.

## 6.2.8 SNS PC Board

Each sensor consists of an LED and photo transistor. When documents are placed on the ADF tray or are moving, a shutter in the document sensor opens. The light from the LED turns the photo transistor "ON", and the output voltage from the sensor becomes a "Low" level. With no document on the ADF tray, the shutter interrupts the light path, and output from the sensor is kept at a "High" level. Operation of the RP Sensor is exactly the same as the ADF Sensor. The ADF Cover Sensor operation is similar, except that the output from the sensor is kept at a "Low" level when the cover is closed and becomes a "High" level when the Printer Cover is opened.

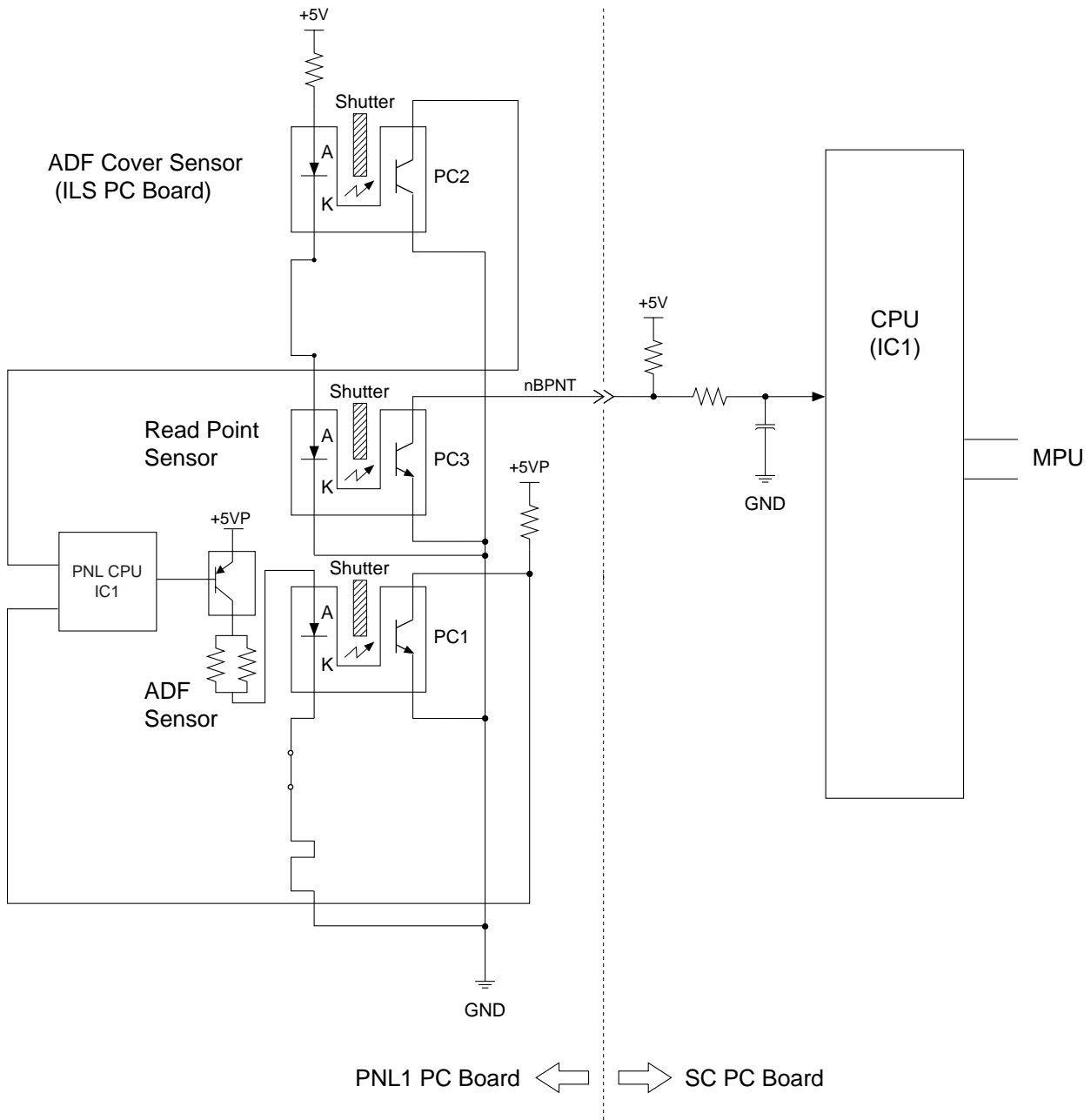



## 6.2.9 Control Panel

The Control Panel consists of the Display PCB and Panel Unit, which display various status information. It is normally interfaced to the main CPU. Keyed input signals are received by the Panel CPU and the data is transferred to the main CPU on the SC PC Board.

The Control Panel performs the following processes simultaneously:

- Key inputting
- LED, LCD display
- Data transmission / reception

### Interface to main CPU

The interfacing between the main CPU and the panel CPU are all executed with commands and responses in the following two formats:

- Command / response (1 byte) + number of data + check sum
- Command / response (1 byte) + number of data + data 1 + data 2 ..... + data n + check sum.

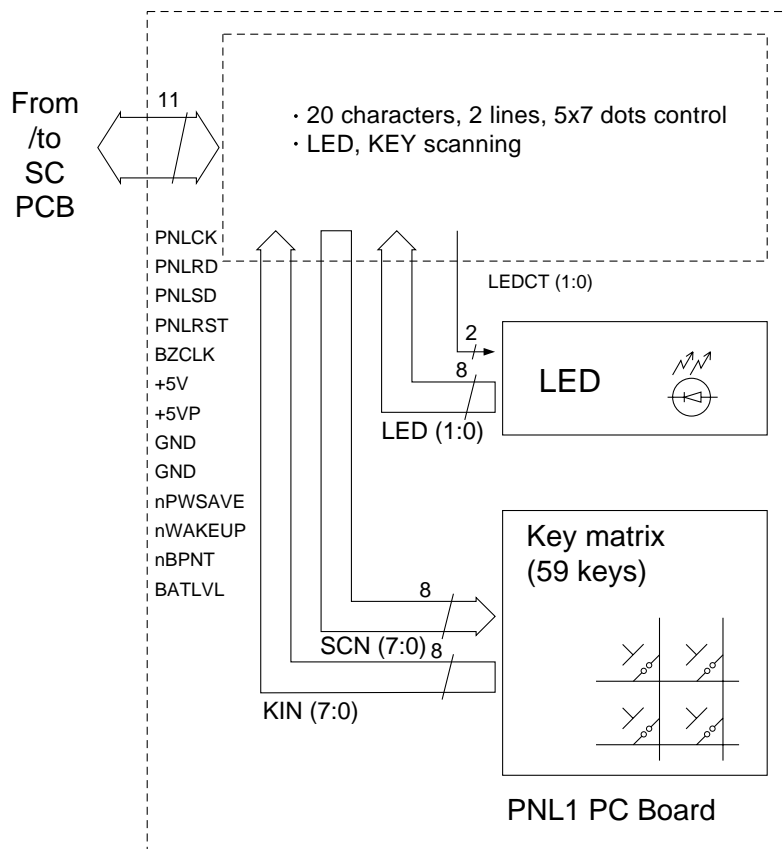

## 6.2.10 Printer Motor Drive Circuit

### Motor Drive Circuit

The Printer Motor is a 4-phase uni-polar PM-type step motor. The step signals (pMMP0A to pMMP3A) are transmitted to IC38 (the Chopper Drive Circuit) from IC3 SHINE output ports. The chopper current is determined by the voltage at IC38, Pin3 and Pin13. The Printer Motor has two speeds, Slow and Constant. The Printer Motor is powered by a +24 VDC supply. When the interlocks are open, the +24 VDC supply is cut off and the Printer Motor stops rotating.

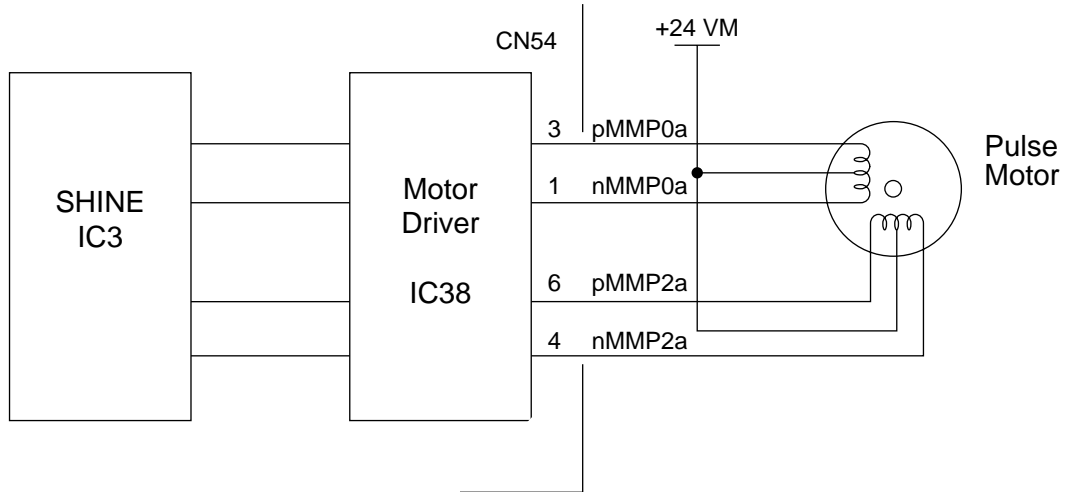

Laser Printer Motor Drive Circuit Block Diagram

## Fuser Lamp Drive Circuit

The Fuser Lamp is powered by 100 VAC (200 VAC). It is driven by the LVPS and controlled by the nSSR signal from the SC PC Board. When the CN103, Pin11 (nSSR) on the LVPS goes LOW, the Fuser Lamp turns ON. This lights up the PC102 LED and activates the TRC100 photo-triac, and VAC 115 VAC is sent to the Fuser Lamp. The time at which TRC100 is actually activated depends on the 100 VAC (200 VAC) sine wave. When the cross-voltage for Pin 6 and Pin 4 of PC102 is other than 0 Volts (sine wave exceeds 0 volts), PC102 inhibits the activation of the triac and turns ON the Fuser Lamp.

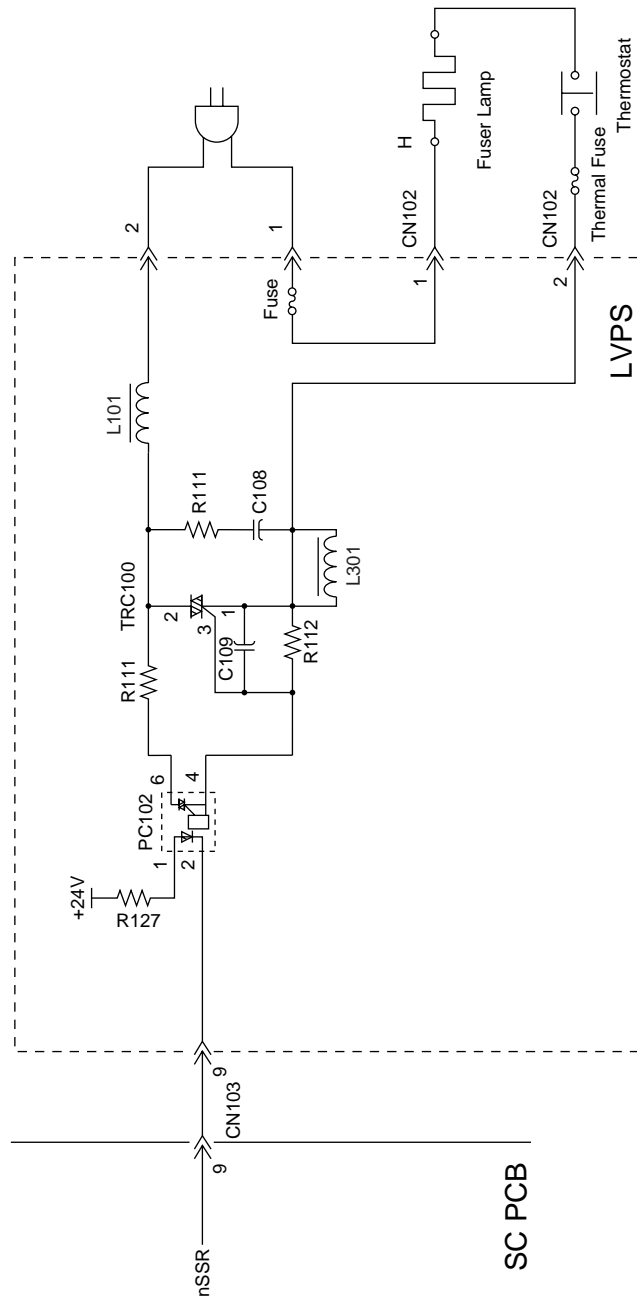

Fuser Lamp Drive Circuit Diagram

## Fuser Temperature Control Circuit

The fuser temperature is controlled by IC1 on the SC PC Board, which contains A/D (Analog/Digital) converters ANI0 to ANI7. The Fuser Temperature Control Circuit uses A/D converter, ANI1. When the PC001 drive current is transmitted from the SC PC Board to the PSU (LVPS), the Fuser Lamp turns ON. IC32 is a comparator with open output at pins 1 and 7 and is used as an abnormal temperature detection circuit. IC32, pin 7, has a high impedance when Q44 is activated, turning ON the Fuser Lamp. An abnormal temperature is detected when the VTH voltage level becomes higher than V+, forcing IC32, pin 7 Low and deactivating Q44. Abnormally low and high temperatures, as well as Thermistor release status, are detected by IC1 (CPU) programming.

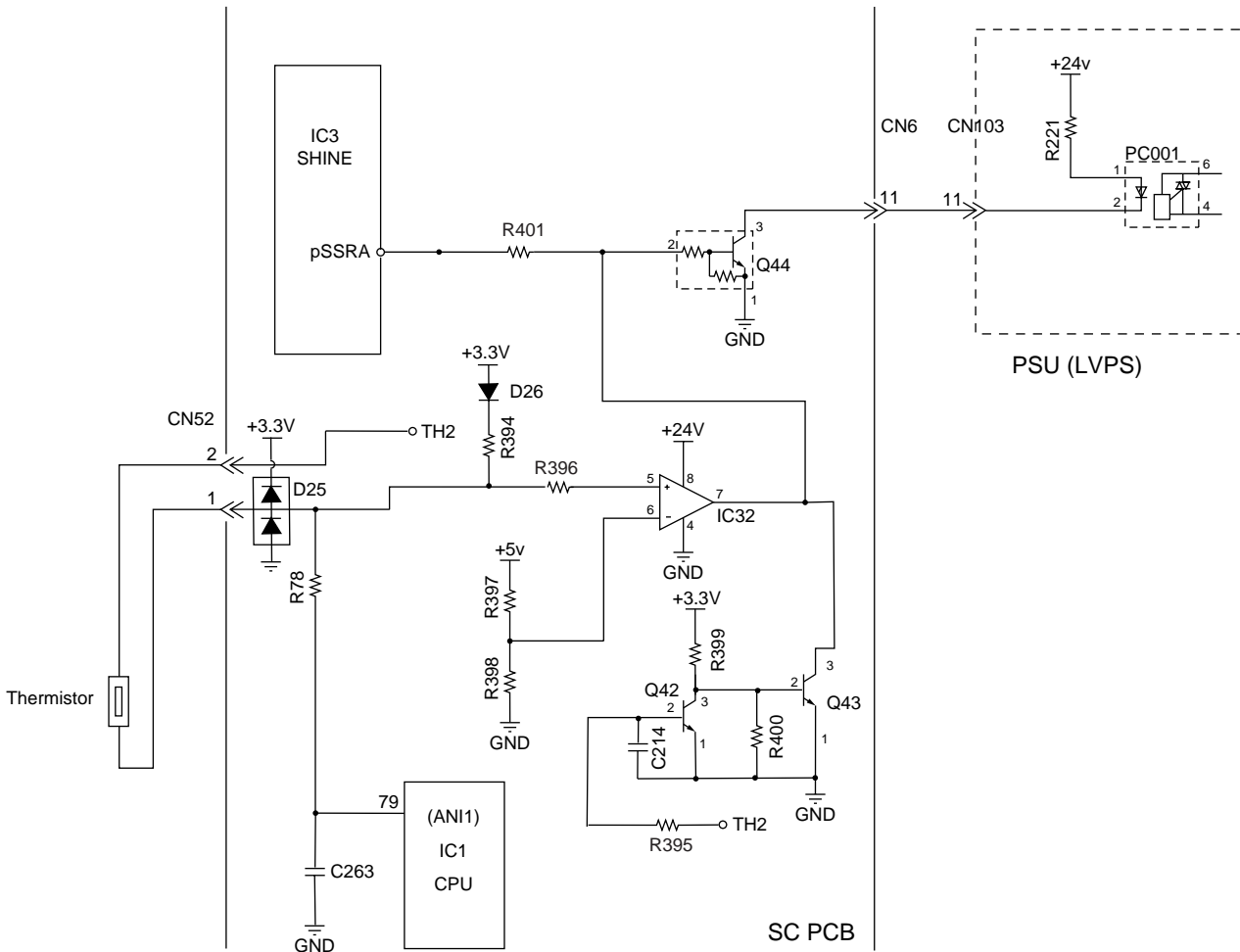

Fuser Temperature Control Circuit Diagram

### High Voltage Drive Circuit (Charging, Development and Transfer)

High Voltage is provided through a DC to DC converter, which changes the +24 VDC supply voltage to -650 VDC, and output approximately 0.64 KVAC (Steady current: 200  $\mu$ A) for the Charging Block. The Developer Circuit converts the +24 VDC to between -300 VDC for the development bias, and outputs 1,500 VAC (p-p) at a frequency of 1.650 kHz to charge the toner. The Transfer Circuit changes the +24 VDC supply voltage to approximately +280 VDC (MAX) (steady current: 3  $\mu$ A/-1500 VDC steady voltage).

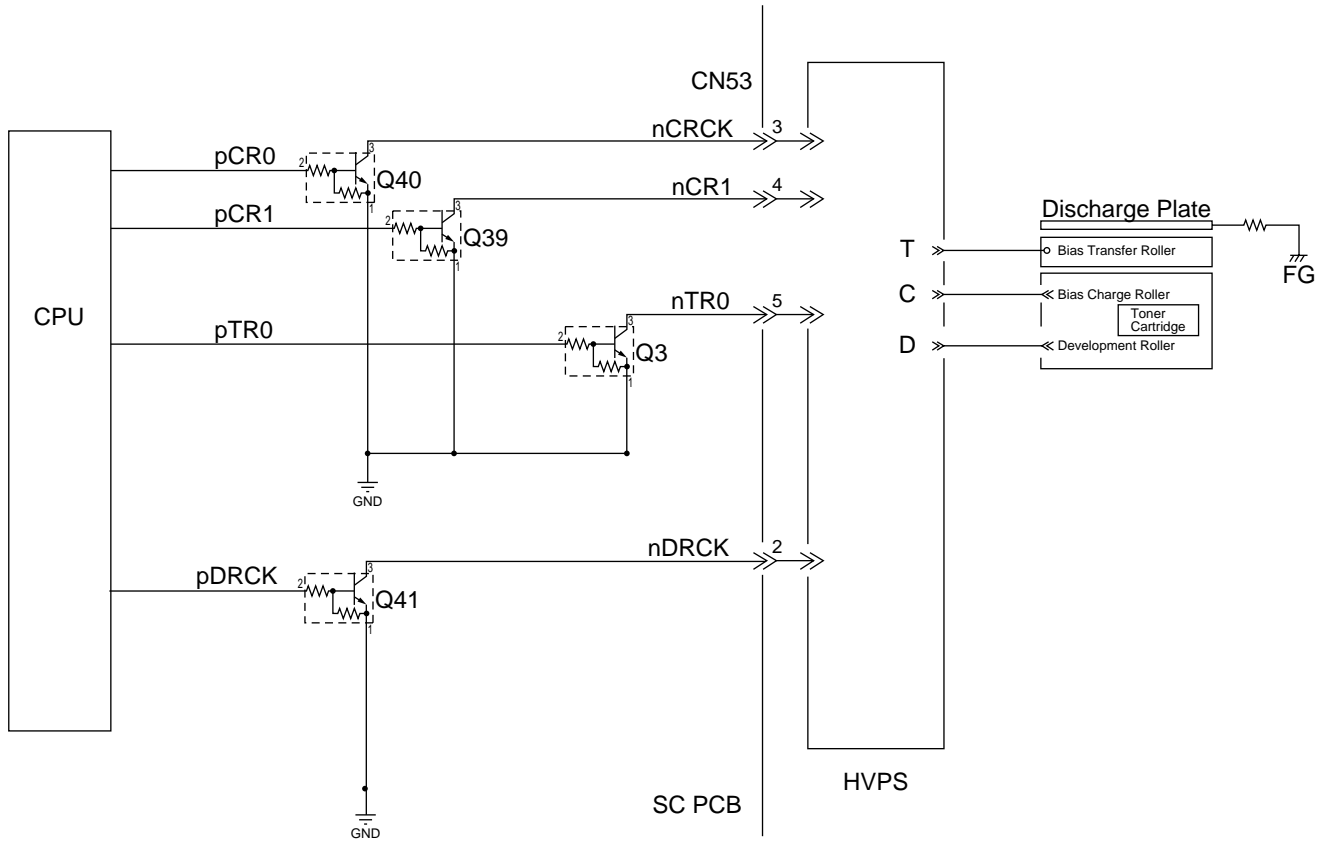

High Voltage Drive Circuit

### 6.2.11. Interlock Safety Circuit

This safety circuit turns OFF the +24 VDC supply voltages when the Cover is opened. When the Cover is opened, the microswitch(es) on the ILS PC Board are de-actuated, turning OFF +24 VDC to the Printer Drive Circuit, the High Voltage Power Supply, and the Paper Feed Solenoid Circuits, turning OFF the +5 VDC supply voltage for the Laser Driver circuits on the Laser Unit.

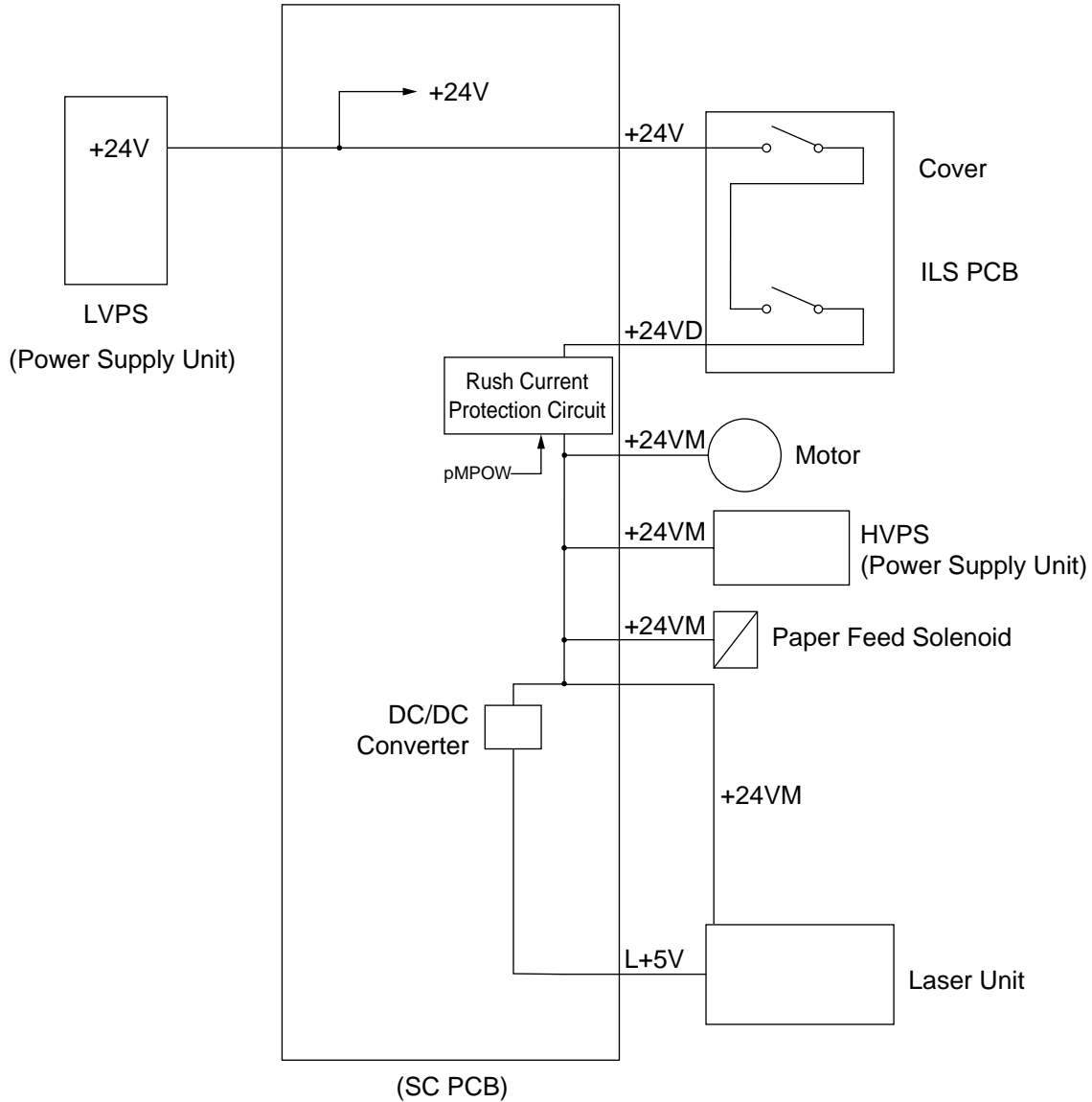

Interlock Safety Circuit Block Diagram

### 6.2.12 Laser Unit (LSU) Control Circuit

The laser control signals are described below.

#### nLDEN

The LSU is activated when this output signal is LOW. If an error occurs, the nLDEN output signal level goes High and the LSU is deactivated.

#### nVIDEO

This is the actual Data Signal. The Laser is ON when the nVIDEO output signal level is LOW.

#### nHSYNC

This horizontal synchronization signal transmitted from the Beam Detection Sensor sets the horizontal position of the laser beam as it crosses the OPC Drum.

#### nSTART

This is the Scanner Motor Control Signal. The Scanner Motor rotates when the nSTART output signal level is LOW.

#### nREADY

A Phased-Lock Loop (PLL) circuit keeps the Scanner Motor speed constant when the nREADY is at a Low output signal level.

#### CLK

This is the Scanner Motor Clock.

#### nS/H

This is the Sample Hold Signal in order to adjust the Laser power. When the Laser switches on compulsorily, the Laser Power is adjusted to a suitable level and held until the next duty cycle in order to keep the Laser Power stable.

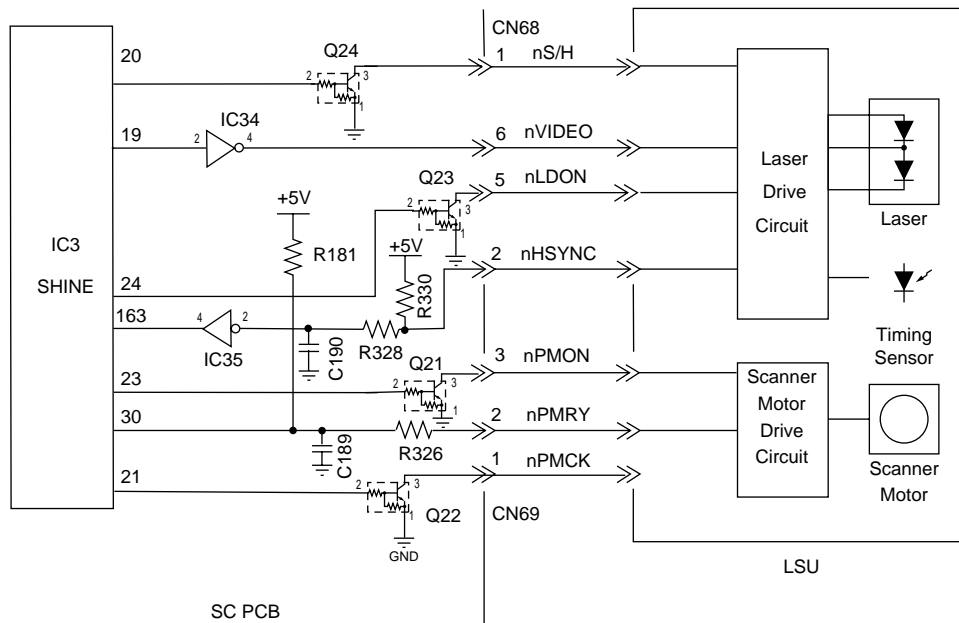

Laser Unit Control Circuit Block Diagram

### 6.2.13 Power Supply Unit (LVPS)

#### Block Diagram of DZEA000057

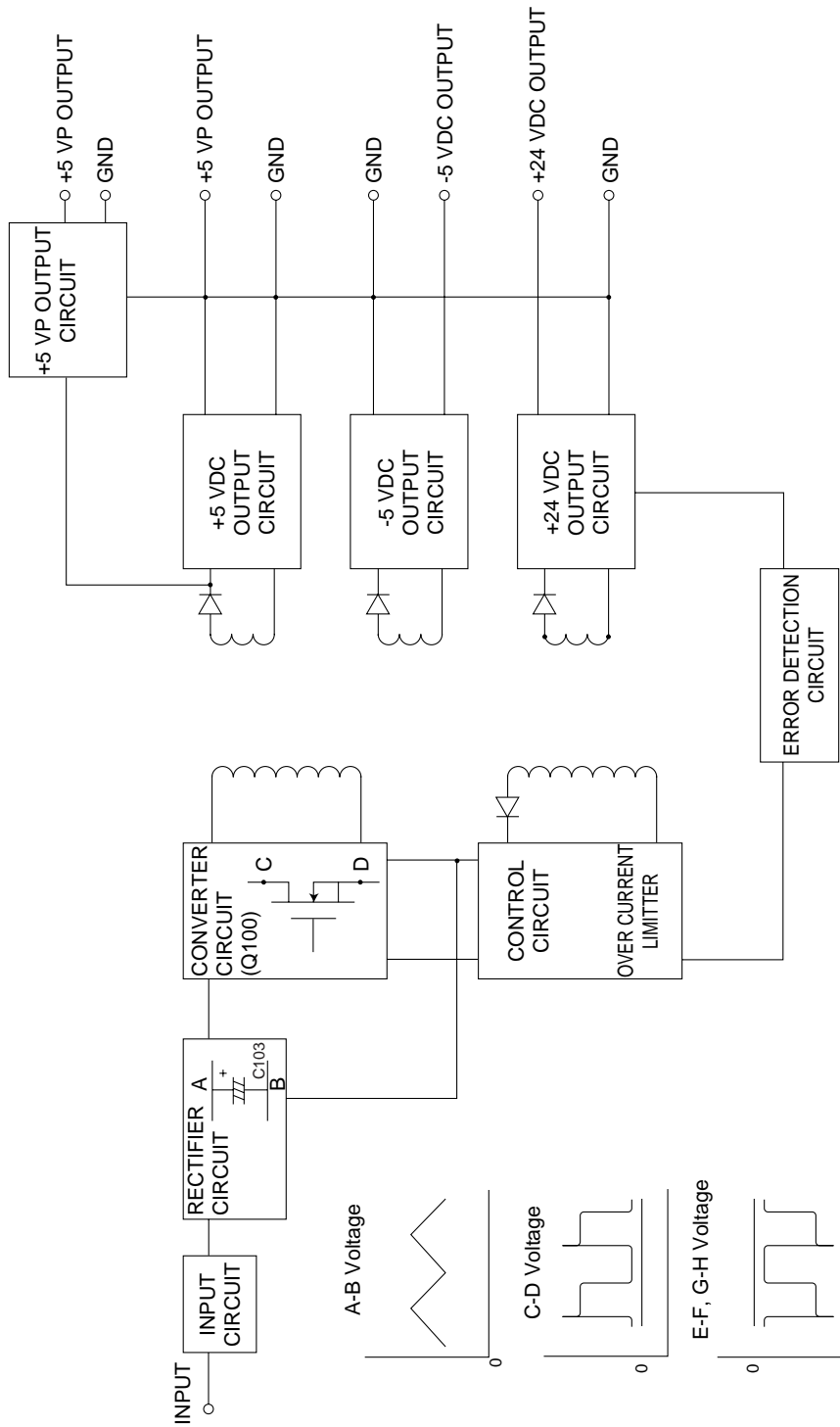



## DZEA000057

### Input Circuit

AC line voltage travels to the rectifying circuit through the line filter. The line filter eliminates RFI noise which may otherwise pass to the AC line from the power supply unit. It also protects the power supply unit from transient noise which may pass into the unit from the AC line.

### Rectifying Circuit

AC power is rectified by D100 and charges C103 to make high DC voltage, then supply power to converter circuit.

Kick-on voltage for control IC (IC105) is supplied AC power through R134, R135 and R136.

Inrush current is limited by TH100.

### Converter Circuit

A IC (IC105), in combination with transformer T100, form a switching power supply circuit using the RCC (Ringing Choke Converter) system.

As soon as power is applied to the Power Supply Unit, AC line voltage is rectified by D100 and is smoothed by capacitor C103. The protection circuit at the time of start-up is controlled by an IC (IC105) and resistors R134, R135 and R136.

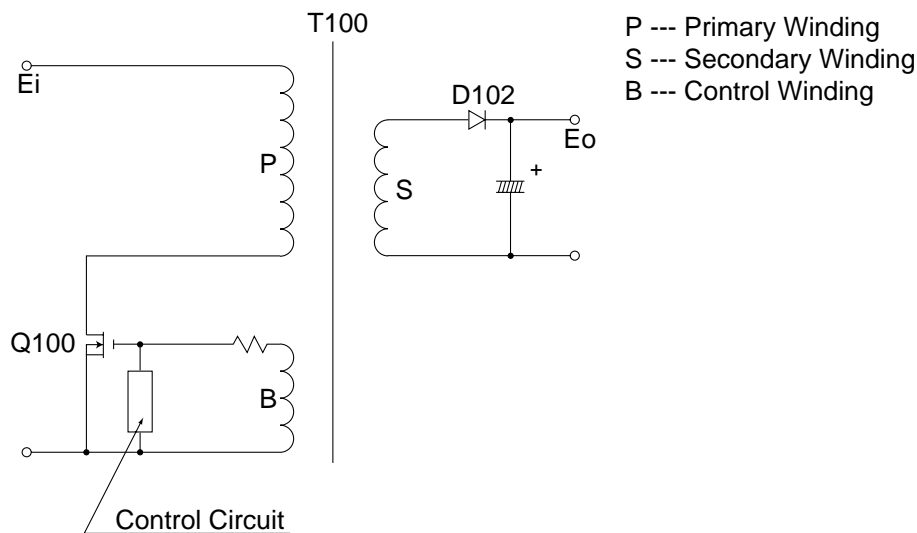

### Main Switching Circuit

In the above circuit, when the main switching transistor, Q100, is turned On, input voltage,  $E_i$ , is supplied to the primary winding of transformer T100. However, no current will flow through diode D102 of the secondary side, due to reverse polarity of the secondary winding causing no current flow within T100. But the transformer charges with energy. When Q100 is turned Off, the supply voltage to the primary winding shuts off and the windings of T100 change polarity, allowing D102 to conduct, releasing the energy accumulated in T100 to the circuit. When the energy is discharged through D102, Q100 turns on, once again reversing the polarity on T100 windings, creating a self-oscillation circuit.

The value of output voltage is

$$E_o = d / (1 - d) * E_i$$

$$d = T_{on} / T_s$$

$T_{on}$  : ON time of Q100

$T_s$  : Period of oscillation

Equivalent circuit model for the RCC.

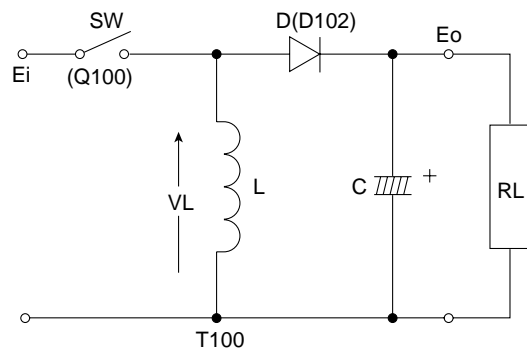

In the equivalent circuit ; When SW is ON, current flows

$$SW \rightarrow L$$

When SW is OFF, current flows

$$L \rightarrow D \rightarrow R_L$$

The value of inductance increase current between ON period. ( $d * T_s$ )

$$I_L = E_i / L * d * T_s \dots \dots \dots (1)$$

The value of inductance decrease current between OFF period. ( $(1 - d) * T_s$ ) \dots \dots \dots (2)

From equation (1) and (2),

$$E_o = d / (1 - d) * E_i$$

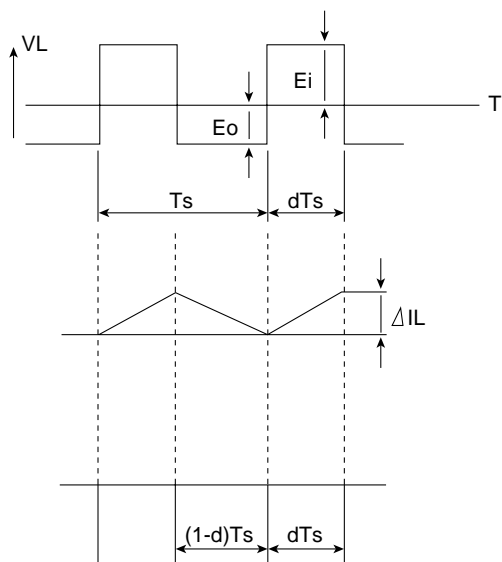

In the actual circuit, the fixed output voltages are obtained by changing the winding ratio of transformer T100. In this converter circuit, the output voltages are stabilized by controlling the duty cycle of the ON and OFF timing of the transistor. In this power supply, the bias winding is built into the transformer. The power supply has four outputs, +24 VDC, -5 VDC, +5 VP and +5 VDC. The +24 VDC output is protected by the Error Detection Circuit, and the +5VDC, +5 VP and -5 VDC outputs are protected by the circuitry inside of the voltage regulator IC.

### Control Circuit and Error Detection Circuit

The control circuit amplifies the output of the duty cycle according to the error voltage detected by the Error Detection Circuit, and drives the main transistor Q100. The method used to change the duty cycle is to change the ON time period. When the output voltage of the +24 VDC circuit rises, the current of photo coupler PC103 increases, the output pulse width of the control circuit decreases and the ON time period of Q100 decreases. This control circuit decides the minimum OFF time period by itself. When the oscillation frequency becomes higher and the OFF time period becomes minimum, the OFF time period remains unchanged and only the ON time period decreases. This way, there is a upper limit of the oscillation frequency and the duty cycle is expanded.

## **Over Current Limiter (O.C.L)**

The +24 VDC output is limited by Ton MAX Limiter (ON time period of transistor Q100) which is part of the control circuit. The +5 VP, -5 VDC and +5 VDC outputs have over current limiters provided inside the voltage regulator.

## 7 Exploded View & Parts List

### 7.1. Destination Codes

**Note:**

1. Panasonic Document Imaging Company and other Panasonic Sales Companies reserve the right to change any information enclosed herein without prior notification.  
(This includes, but is not limited to, parts pricing and availability, and text)
2. Electrical parts supplied may include previously used components.
3. Important safety notice  
Components identified by  mark have special characteristics important for safety.  
When replacing any of these components, use only manufacturer's specified parts.
4. In New Parts column, "N" indicates part is used only in UF-5100 / 6000 / 6100 model, "C" indicates part is used in previous models.

Code	Destination	Code	Destination	Code	Destination	Code	Destination	Code	Destination
AA	Austria	AM	Switzerland	EN	Denmark, Finland, Norway, Sweden	YH	Hungary	YX	Singapore
AB	England	AP	Portugal			YJ	Czech, Slovakia		
AE	Taiwan	AR	Belgium	YA	Panama, Peru, Chile, Argentina, Brazil (200 VAC Power Supply)	YM	Malaysia		
AG	Germany	AT	Turkey			YR	Russia, Ukraine		
AH	Netherlands	AU	USA, Puerto Rico, Canada	YC	Universal 200 VAC Power Supply Version	YS	Saudi Arabia		
AJ	Spain	AV	France			YT	Thailand		
AK	Hong Kong SAR, PRC	AW	New Zealand	YF	Poland	YV	China		
AL	Australia	EE	Italy	YG	Greece	YW	South Africa		

#### 7.1.1. Destination Code Matrix

**Note:**

The table indicates the model distribution by Destination Codes.

	AA	AB	AE	AG	AH	AJ	AK	AL	AM	AP	AR	AT	AU	AV	AW	EE	EN	YA	YC	YF	YG	YH	YJ	YM	YR	YS	YT	YV	YW	YX
<b>UF-580</b>	1	1	-	1	1	1	1	-	1	1	1	1	-	1	-	1	1	-	1	1	1	1	1	-	-	1	1	-	1	-
<b>UF-780</b>	-	-	-	-	-	-	-	-	-	-	-	-	1	-	-	-	-	-	-	-	-	-	-	-	-	-	-	-	-	-
<b>UF-590</b>	1	1	1	1	1	1	1	1	1	1	1	1	-	1	1	1	1	1	1	1	1	1	1	1	1	1	1	1	1	1
<b>UF-790</b>	-	-	-	-	-	-	-	-	-	-	-	-	1	-	-	-	-	-	-	-	-	-	-	-	-	-	-	-	-	-
<b>UF-5100</b>	-	-	-	1	1	1	1	-	1	1	1	-	-	1	-	1	1	-	1	-	-	-	-	-	-	1	1	-	1	-
<b>UF-6000</b>	-	-	-	-	-	-	-	-	-	-	-	-	1	-	-	-	-	-	-	-	-	-	-	-	-	-	-	-	-	-
<b>UF-6100</b>	-	1	1	1	1	-	1	1	1	1	1	1	-	1	1	1	1	-	1	1	1	1	1	1	1	1	1	1	1	1





Safety Mark	Ref. No.	Part Number	Part Name	New Parts	Remarks	Destination Codes																																
						AA	AB	AE	AG	AH	AJ	AK	AL	AM	AP	AR	AT	AU	AV	AW	EE	EN	YA	YC	YF	YG	YH	YJ	YM	YR	YS	YT	YV	YW	YX			
	1011		PC Board, SRU		See Sect. 7.11 PC Board / Harness	-	-	1	-	-	-	1	-	-	-	-	1	1	-	-	-	-	-	1	1	-	1	1	-	1	-	-	-	-	-	1	1	1
	1016	DZFP000723	Harness, SC-SPK	C	For UF-590/790	1	1	1	1	1	1	1	1	1	1	1	1	1	1	1	1	1	1	1	1	1	1	1	1	1	1	1	1	1	1	1	1	1
		DZFP001908		N	For UF-590/790/6000/6100	1	1	1	1	1	1	1	1	1	1	1	1	1	1	1	1	1	1	1	1	1	1	1	1	1	1	1	1	1	1	1	1	1
	19	XTB3+8J	Screw	C	For UF-590/790	1	1	1	1	1	1	1	1	1	1	1	1	1	1	1	1	1	1	1	1	1	1	1	1	1	1	1	1	1	1	1	1	1
		XTB3+8JFJ			For UF-580/780	1	1	-	1	1	1	1	1	-	1	1	1	1	1	1	1	1	1	1	1	1	1	1	1	1	1	1	1	1	1	1	1	1
	1Y	XTB3+10J	Screw	C	For UF-590/790	1	1	1	1	1	1	1	1	1	1	1	1	1	1	1	1	1	1	1	1	1	1	1	1	1	1	1	1	1	1	1	1	1
		XTB3+10JFJ			For UF-580/780	1	1	-	1	1	1	1	1	-	1	1	1	1	1	1	1	1	1	1	1	1	1	1	1	1	1	1	1	1	1	1	1	1
	B1	DZPB000007	Screw	C	For UF-590/790	1	1	1	1	1	1	1	1	1	1	1	1	1	1	1	1	1	1	1	1	1	1	1	1	1	1	1	1	1	1	1	1	1
					For UF-580/780	1	1	-	1	1	1	1	1	1	-	1	1	1	1	1	1	1	1	1	1	1	1	1	1	1	1	1	1	1	1	1	1	1
	C2	DZPB000020	Screw	C	For UF-590/790	1	1	1	1	1	1	1	1	1	1	1	1	1	1	1	1	1	1	1	1	1	1	1	1	1	1	1	1	1	1	1	1	1
		DZPB000054			For UF-580/780	1	1	-	1	1	1	1	1	-	1	1	1	1	1	1	1	1	1	1	1	1	1	1	1	1	1	1	1	1	1	1	1	1
				N	For UF-590/790/6000/6100	1	1	1	1	1	1	1	1	1	1	1	1	1	1	1	1	1	1	1	1	1	1	1	1	1	1	1	1	1	1	1	1	1
					For UF-580/780/5100	1	1	-	1	1	1	1	1	1	-	1	1	1	1	1	1	1	1	1	1	1	1	1	1	1	1	1	1	1	1	1	1	1

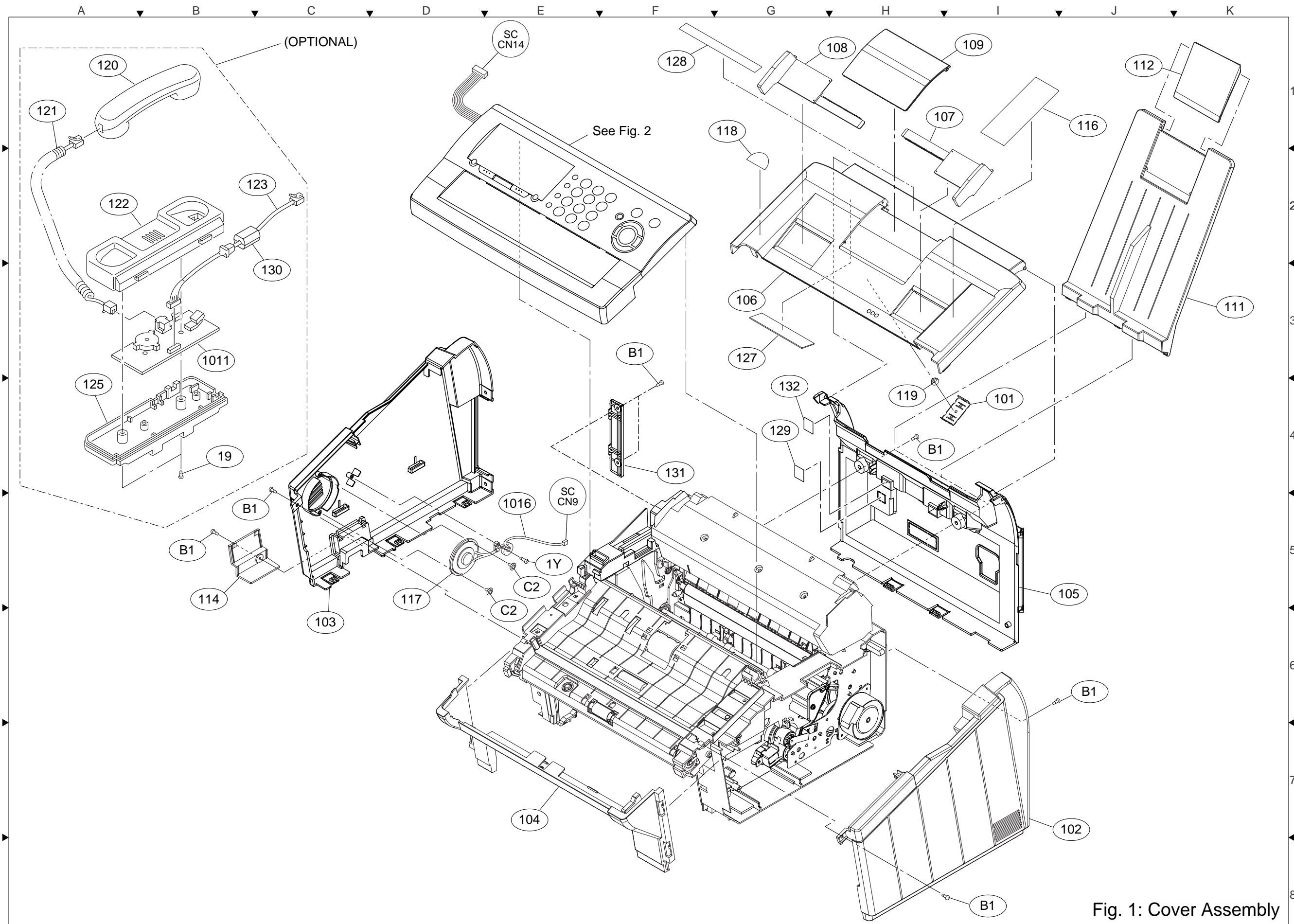

Fig. 1: Cover Assembly













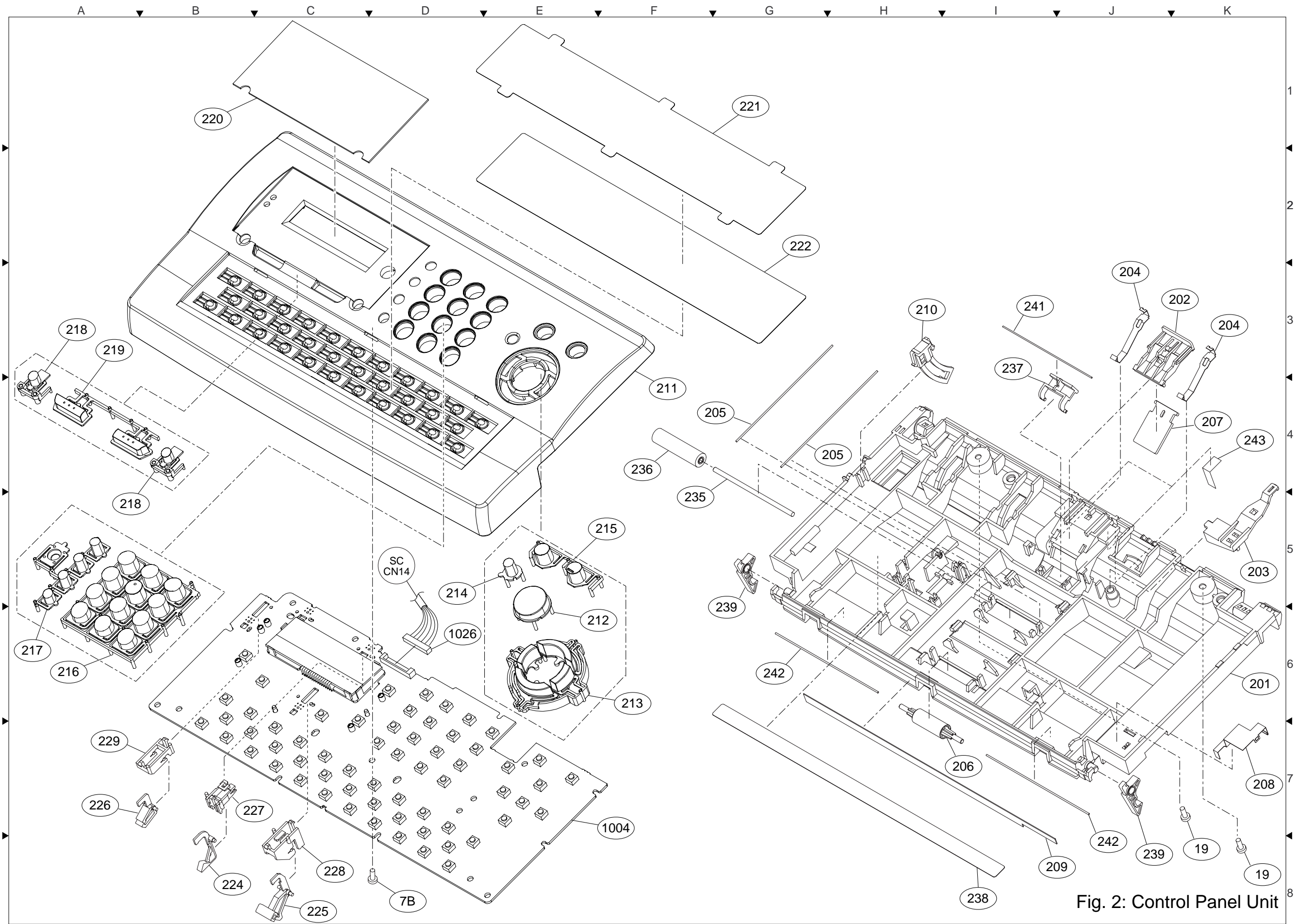

Fig. 2: Control Panel Unit









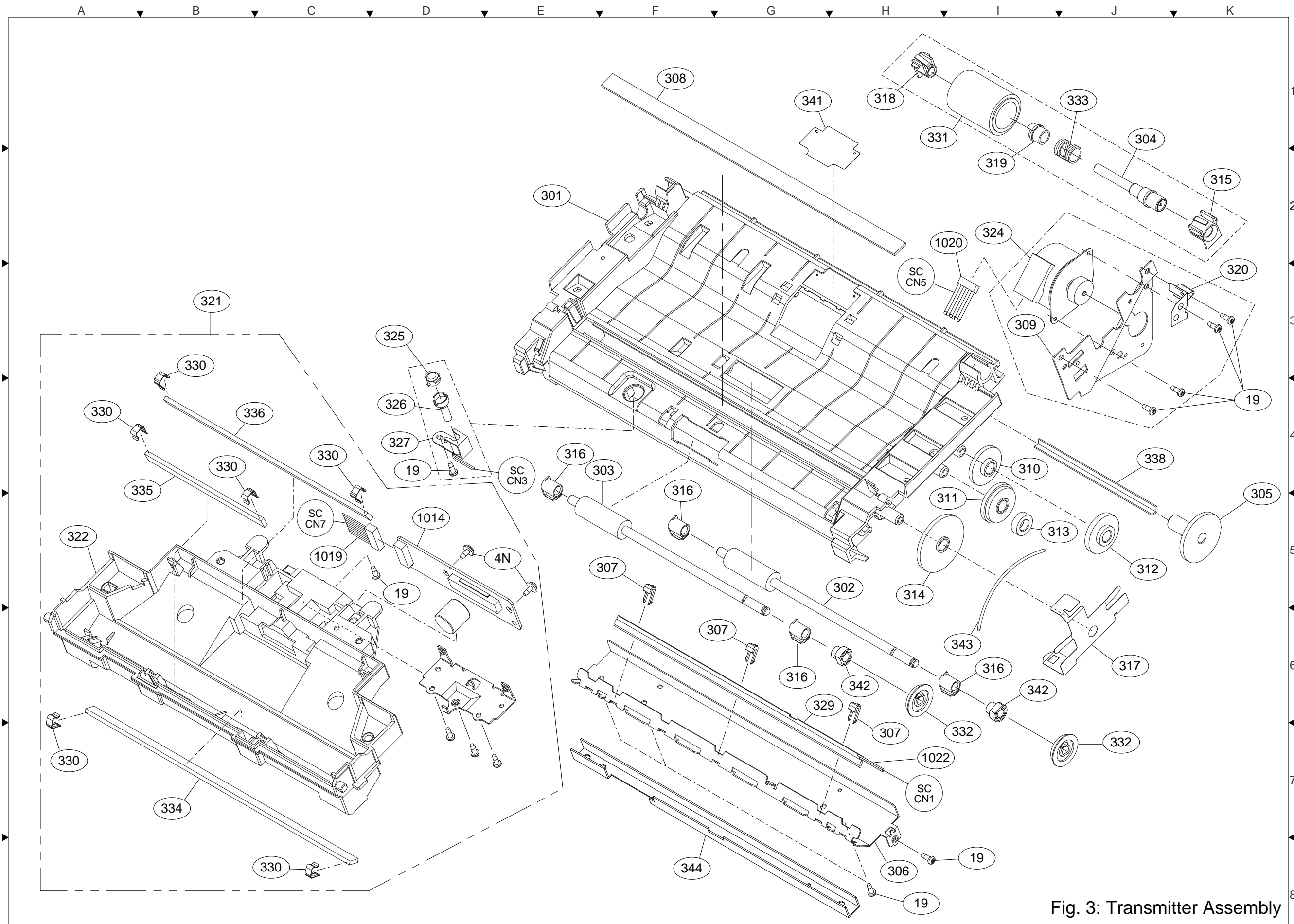

Fig. 3: Transmitter Assembly





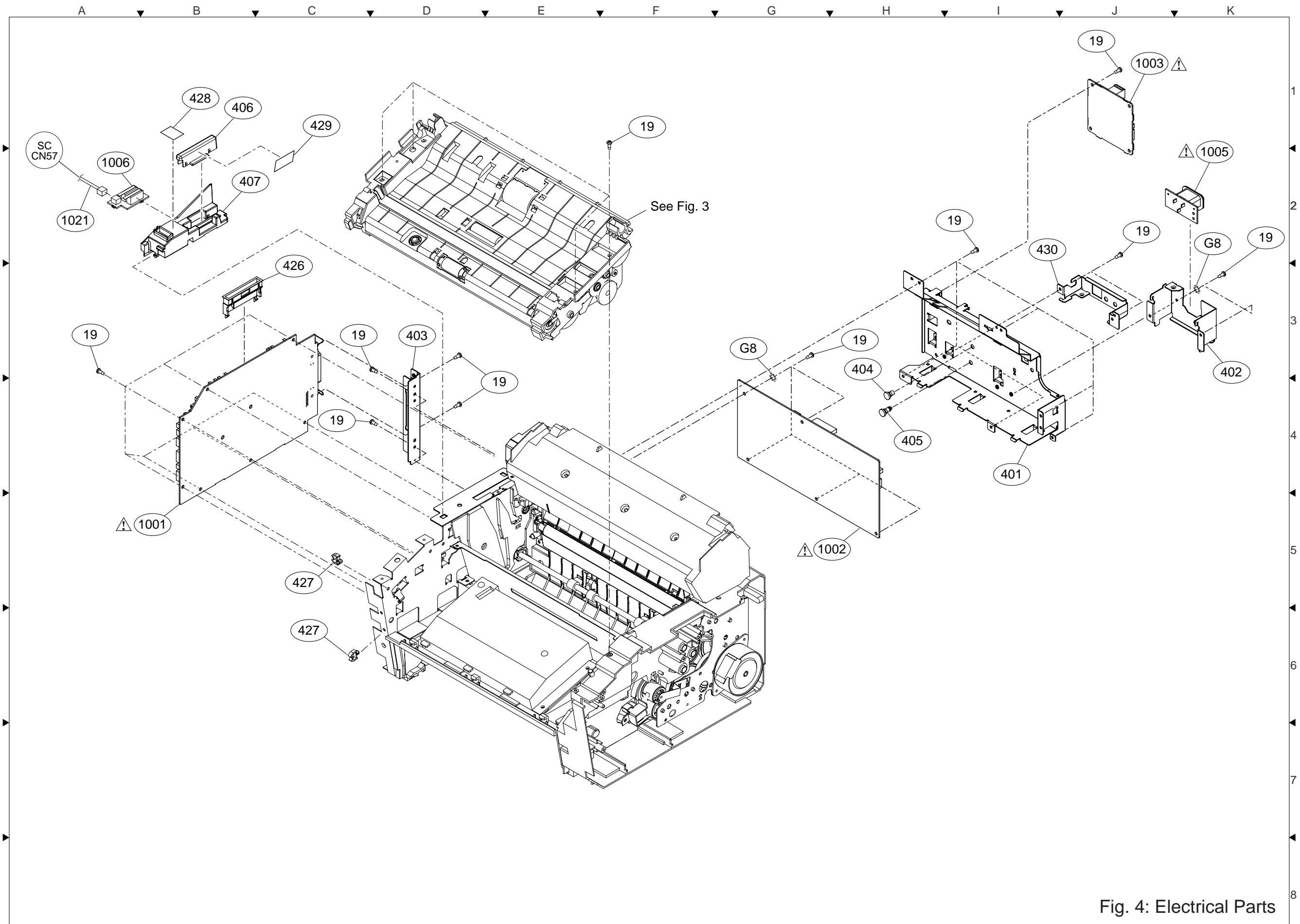

Fig. 4: Electrical Parts









Safety Mark	Ref. No.	Part Number	Part Name	New Parts	Remarks	Destination Codes																																
						AA	AB	AE	AG	AH	AJ	AK	AL	AM	AP	AR	AT	AU	AV	AW	EE	EN	YA	YC	YF	YG	YH	YJ	YM	YR	YS	YT	YV	YW	YX			
	19	XTB3+8J	Screw	C	For UF-590/790	1	1	1	1	1	1	1	1	1	1	1	1	1	1	1	1	1	1	1	1	1	1	1	1	1	1	1	1	1	1	1	1	
		For UF-580/780			1	1	-	1	1	1	1	-	1	1	1	1	1	-	1	1	-	1	1	1	1	1	1	-	-	1	1	-	1	-	-	-		
		For UF-590/790/6000/6100			1	1	1	1	1	1	1	1	1	1	1	1	1	1	1	1	1	1	1	1	1	1	1	1	1	1	1	1	1	1	1	1	1	1
		For UF-580/780/5100			1	1	-	1	1	1	1	-	1	1	1	1	1	-	1	1	-	1	1	1	1	1	1	-	-	1	1	-	1	-	-	-		
	1Y	XTB3+10J	Screw	C	For UF-590/790	1	1	1	1	1	1	1	1	1	1	1	1	1	1	1	1	1	1	1	1	1	1	1	1	1	1	1	1	1	1	1		
		For UF-580/780			1	1	-	1	1	1	1	-	1	1	1	1	1	-	1	1	-	1	1	1	1	1	1	-	-	1	1	-	1	-	-			
		N		For UF-590/790/6000/6100	1	1	1	1	1	1	1	1	1	1	1	1	1	1	1	1	1	1	1	1	1	1	1	1	1	1	1	1	1	1	1	1	1	
				For UF-580/780/5100	1	1	-	1	1	1	1	-	1	1	1	1	1	-	1	1	-	1	1	1	1	1	1	-	-	1	1	-	1	-	-			
	4N	XSN3+W8FC	Screw	C	For UF-590/790	1	1	1	1	1	1	1	1	1	1	1	1	1	1	1	1	1	1	1	1	1	1	1	1	1	1	1	1	1	1	1		
		For UF-580/780			1	1	-	1	1	1	1	-	1	1	1	1	1	-	1	1	-	1	1	1	1	1	1	-	-	1	1	-	1	-	-			
		N		For UF-590/790/6000/6100	1	1	1	1	1	1	1	1	1	1	1	1	1	1	1	1	1	1	1	1	1	1	1	1	1	1	1	1	1	1	1	1	1	
				For UF-580/780/5100	1	1	-	1	1	1	1	-	1	1	1	1	1	-	1	1	-	1	1	1	1	1	1	-	-	1	1	-	1	-	-			
	B9	DZJM000171	Snap Ring	C	For UF-590/790	1	1	1	1	1	1	1	1	1	1	1	1	1	1	1	1	1	1	1	1	1	1	1	1	1	1	1	1	1	1	1		
					For UF-580/780	1	1	-	1	1	1	1	-	1	1	1	1	1	-	1	1	-	1	1	1	1	1	1	-	-	1	1	-	1	-	-		
					For UF-6000/6100	1	1	1	1	1	1	1	1	1	1	1	1	1	1	1	1	1	1	1	1	1	1	1	1	1	1	1	1	1	1	1	1	1
					For UF-5100	1	1	1	1	1	1	1	1	1	1	1	1	1	-	1	1	1	1	1	1	1	1	1	1	1	1	1	1	1	1	1	1	1
	K5	XUC5VM	E-Ring	C	For UF-590/790	1	1	1	1	1	1	1	1	1	1	1	1	1	1	1	1	1	1	1	1	1	1	1	1	1	1	1	1	1	1	1		
					For UF-580/780	1	1	-	1	1	1	1	-	1	1	1	1	1	-	1	1	-	1	1	1	1	1	1	-	-	1	1	-	1	-	-		
					For UF-6000/6100	1	1	1	1	1	1	1	1	1	1	1	1	1	1	1	1	1	1	1	1	1	1	1	1	1	1	1	1	1	1	1	1	1
					For UF-5100	1	1	1	1	1	1	1	1	1	1	1	1	1	1	-	1	1	1	1	1	1	1	1	1	1	1	1	1	1	1	1	1	1

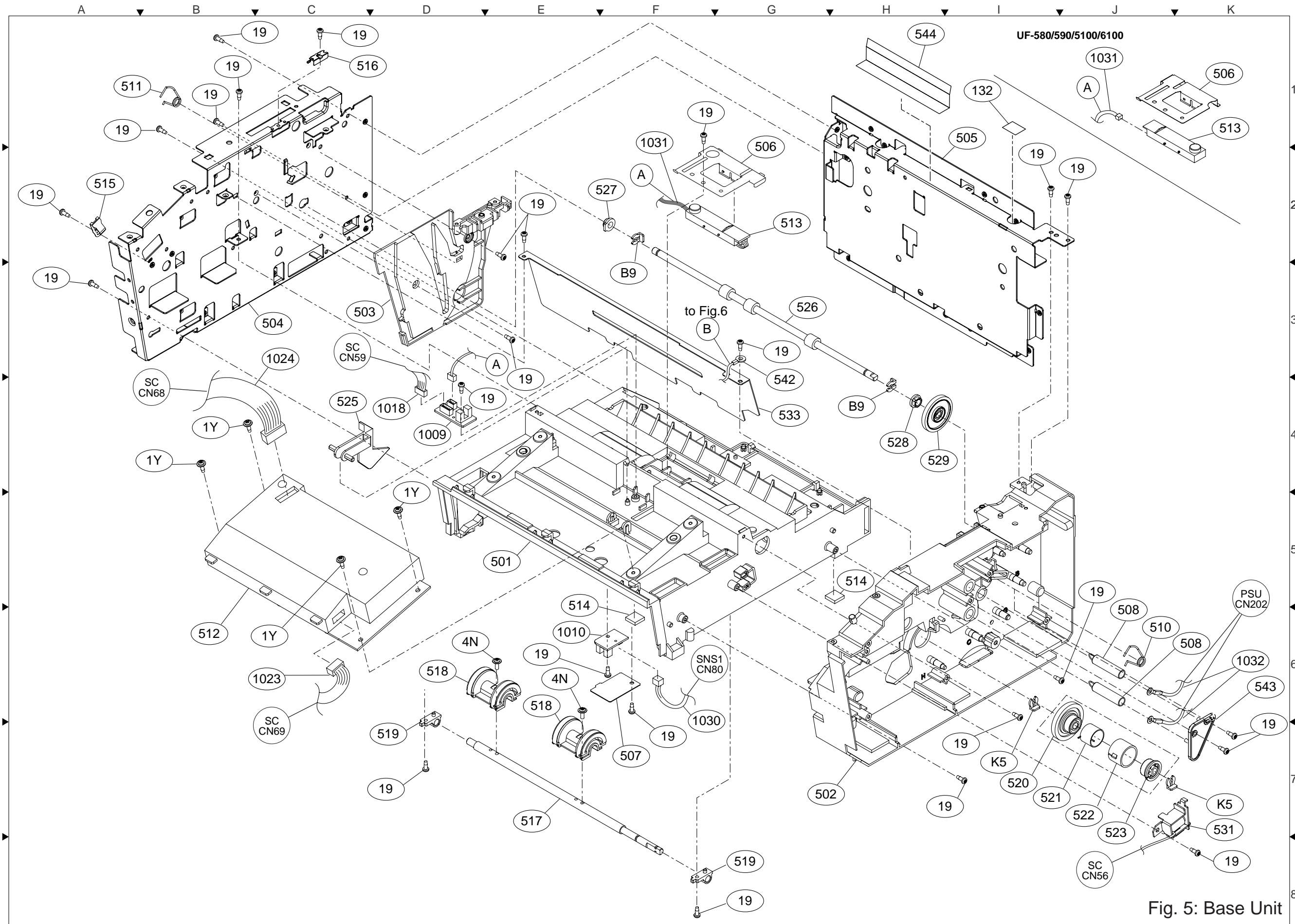

Fig. 5: Base Unit







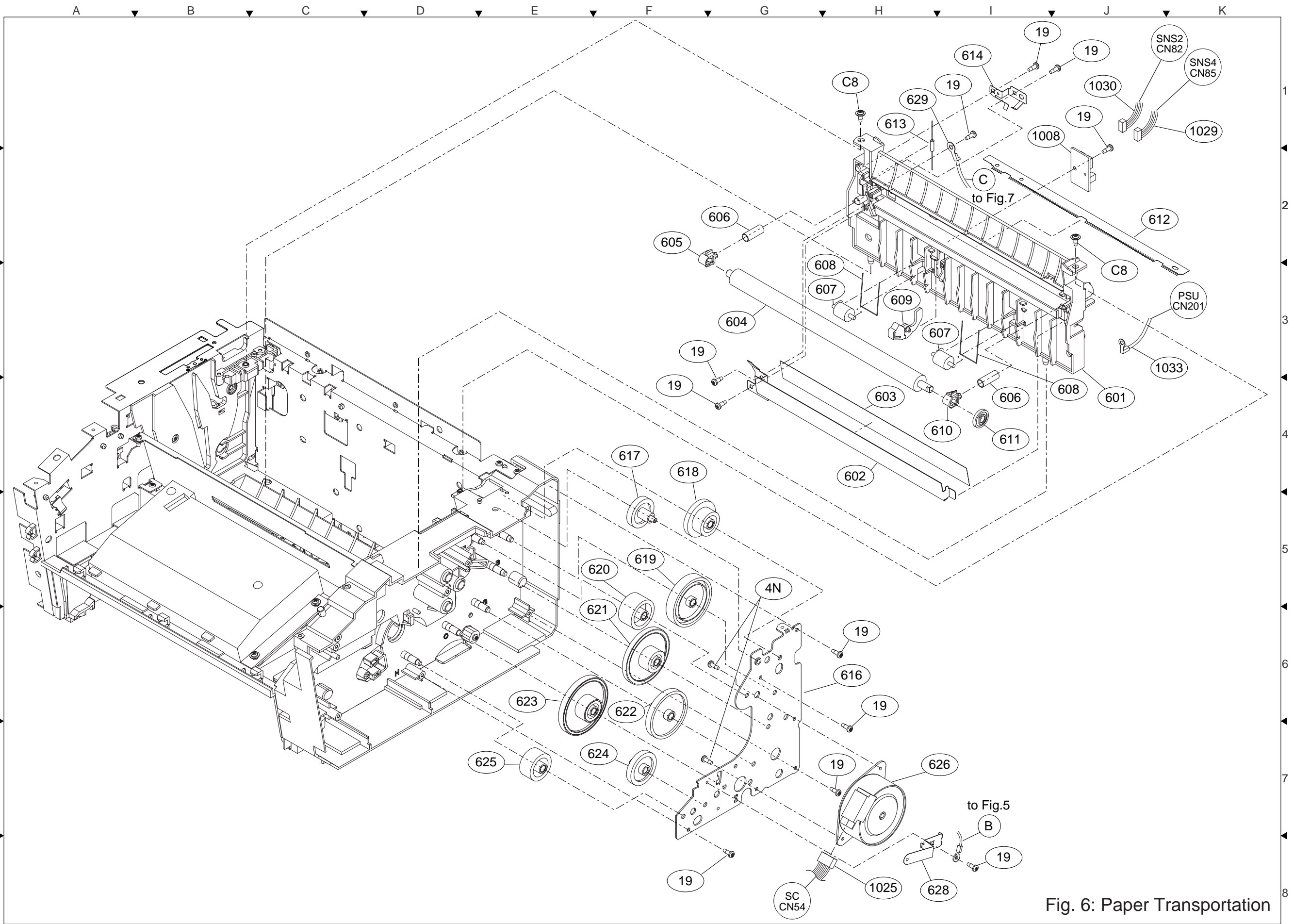

Fig. 6: Paper Transportation











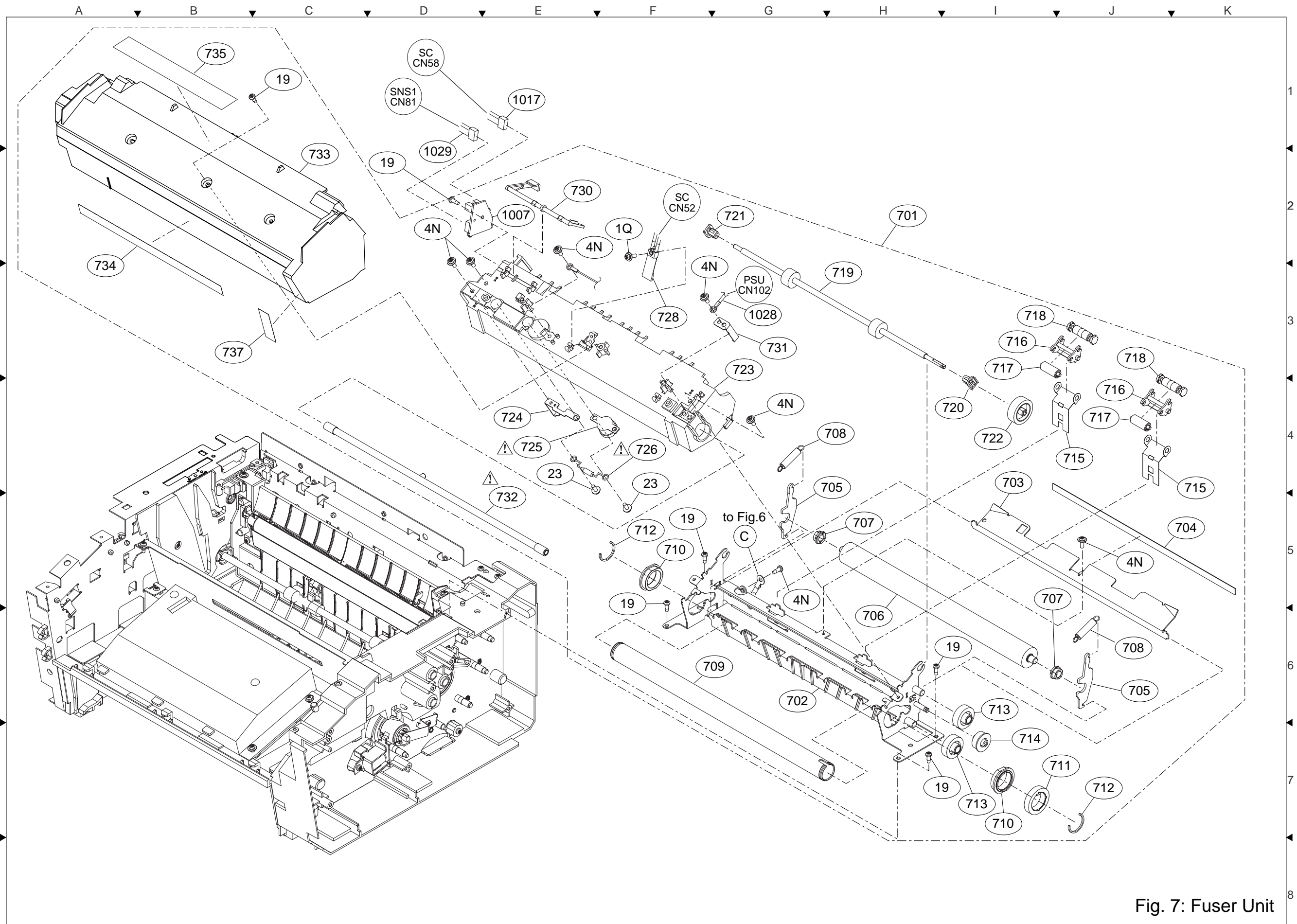

Fig. 7: Fuser Unit



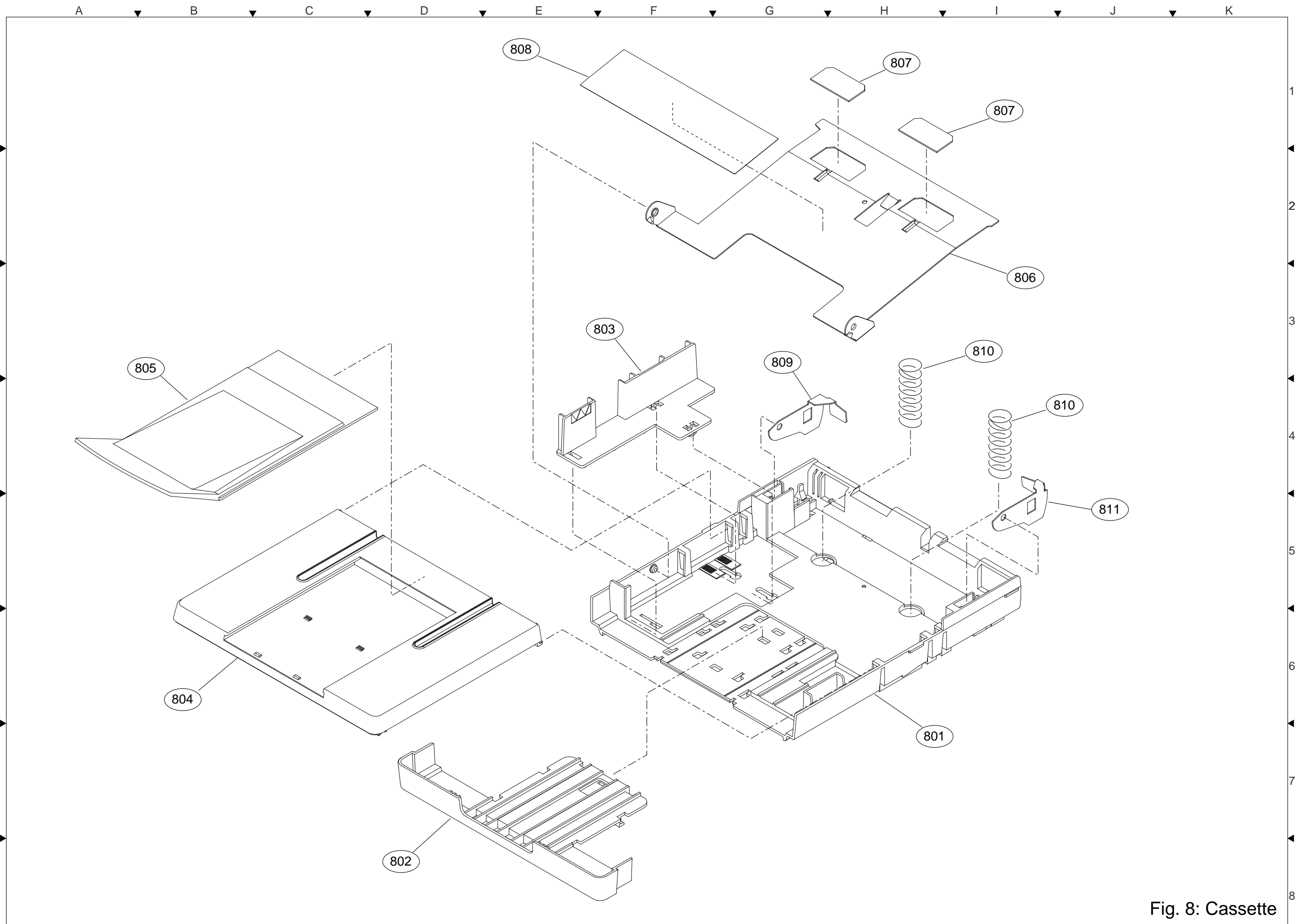

Fig. 8: Cassette





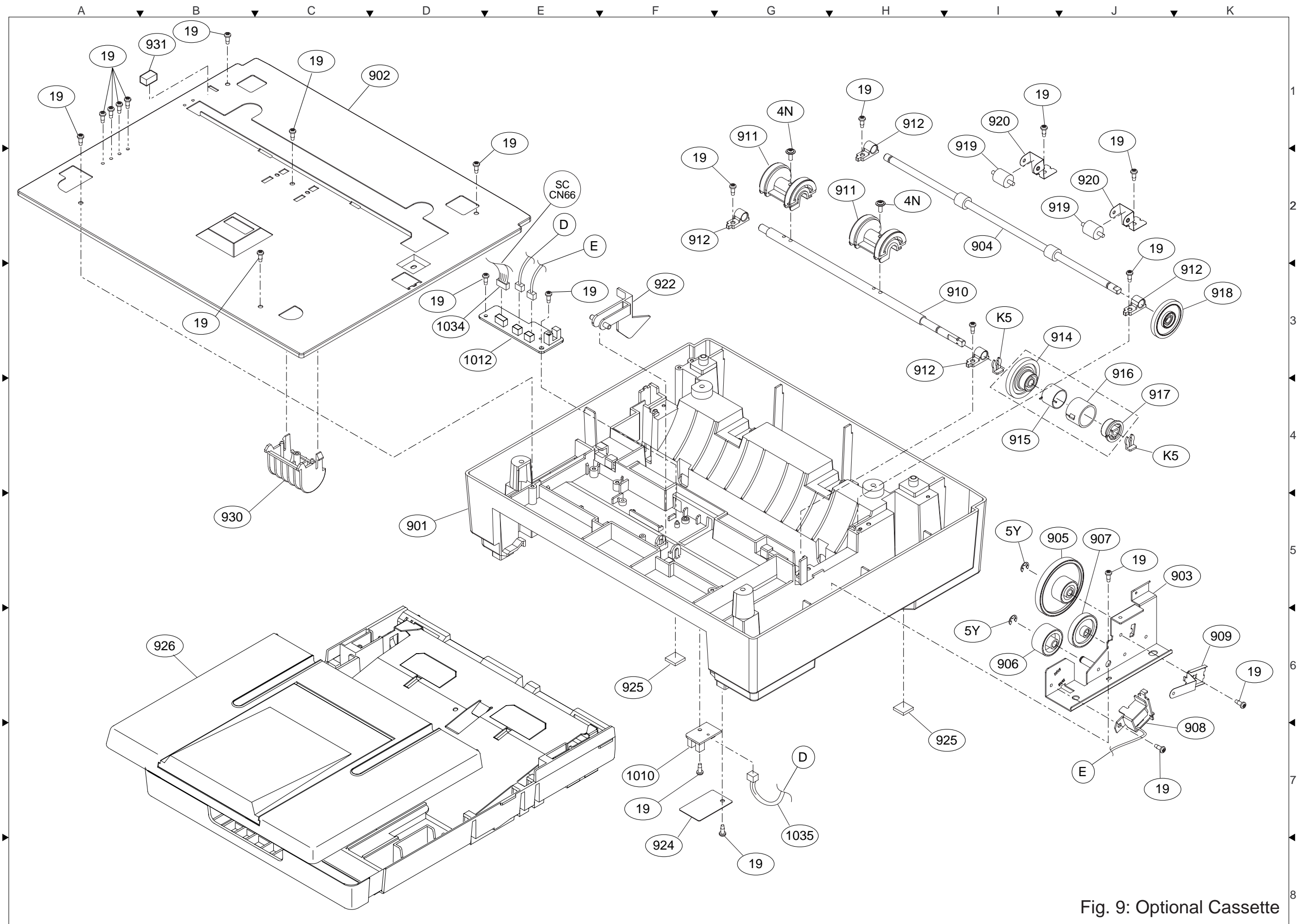

Fig. 9: Optional Cassette









Safety Mark	Ref. No.	Part Number	Part Name	New Parts	Remarks	Destination Codes																									
						AA	AB	AE	AG	AH	AJ	AK	AL	AM	AP	AR	AT	AU	AV	AW	EE	EN	YA	YC	YF	YG	YH	YJ	YM	YR	YS
	1019	DZFP001251	Harness, SC-CCD	C	For UF-590/790	1	1	1	1	1	1	1	1	1	1	1	1	1	1	1	1	1	1	1	1	1	1	1	1	1	1
		DZFP001918		N	For UF-590/790/6000/6100	1	1	1	1	1	1	1	1	1	1	1	1	1	1	1	1	1	1	1	1	1	1	1	1	1	1
	1020	DZFP001216	Harness, SC-TXMOT	C	For UF-590/790	1	1	1	1	1	1	1	1	1	1	1	1	1	1	1	1	1	1	1	1	1	1	1	1	1	
		DZFP001920		N	For UF-590/790/6000/6100	1	1	1	1	1	1	1	1	1	1	1	1	1	1	1	1	1	1	1	1	1	1	1	1	1	1
	1021	DZFP001218	Harness, SC-ILS	C	For UF-590/790	1	1	1	1	1	1	1	1	1	1	1	1	1	1	1	1	1	1	1	1	1	1	1	1	1	
		DZFP001923		N	For UF-590/790/6000/6100	1	1	1	1	1	1	1	1	1	1	1	1	1	1	1	1	1	1	1	1	1	1	1	1	1	1
	1022	DZFP001213	Harness, SC-LED	C	For UF-590/790	1	1	1	1	1	1	1	1	1	1	1	1	1	1	1	1	1	1	1	1	1	1	1	1	1	
		DZFP001921		N	For UF-590/790/6000/6100	1	1	1	1	1	1	1	1	1	1	1	1	1	1	1	1	1	1	1	1	1	1	1	1	1	1
	1023	DZFP001223	Harness, SC-LSU 2	C	For UF-590/790	1	1	1	1	1	1	1	1	1	1	1	1	1	1	1	1	1	1	1	1	1	1	1	1	1	
		DZFP001929		N	For UF-590/790/6000/6100	1	1	1	1	1	1	1	1	1	1	1	1	1	1	1	1	1	1	1	1	1	1	1	1	1	1
	1024	DZFP001222	Harness, SC-LSU 1	C	For UF-590/790	1	1	1	1	1	1	1	1	1	1	1	1	1	1	1	1	1	1	1	1	1	1	1	1	1	1
		DZFP001928		N	For UF-6000/6100	1	1	1	1	1	1	1	1	1	1	1	1	1	1	1	1	1	1	1	1	1	1	1	1	1	1
	1025	DZFP000724	Harness, SC-RXMOT	C	For UF-590/790	1	1	1	1	1	1	1	1	1	1	1	1	1	1	1	1	1	1	1	1	1	1	1	1	1	
		DZFP001909		N	For UF-590/790/6000/6100	1	1	1	1	1	1	1	1	1	1	1	1	1	1	1	1	1	1	1	1	1	1	1	1	1	1
	1026	DZFP001215	Harness, SC-PNL	C	For UF-590/790	1	1	1	1	1	1	1	1	1	1	1	1	1	1	1	1	1	1	1	1	1	1	1	1	1	
		DZFP001919		N	For UF-590/790/6000/6100	1	1	1	1	1	1	1	1	1	1	1	1	1	1	1	1	1	1	1	1	1	1	1	1	1	1
	1027	DZFP001214	Harness, SC-MJR	C	For UF-590/790	1	1	1	1	1	1	1	1	1	1	1	1	1	1	1	1	1	1	1	1	1	1	1	1	1	
		DZFP001917		N	For UF-590/790/6000/6100	1	1	1	1	1	1	1	1	1	1	1	1	1	1	1	1	1	1	1	1	1	1	1	1	1	1
	1028	DZFP001220	Harness, PSU-FUSER	C	For UF-590/790	1	1	1	1	1	1	1	1	1	1	1	1	1	1	1	1	1	1	1	1	1	1	1	1	1	
		DZFP001925		N	For UF-590/790/6000/6100	1	1	1	1	1	1	1	1	1	1	1	1	1	1	1	1	1	1	1	1	1	1	1	1	1	1
	1029	DZFP000728	Harness, SNS1-SNS4	C	For UF-590/790	1	1	1	1	1	1	1	1	1	1	1	1	1	1	1	1	1	1	1	1	1	1	1	1	1	
		DZFP001910		N	For UF-590/790/6000/6100	1	1	1	1	1	1	1	1	1	1	1	1	1	1	1	1	1	1	1	1	1	1	1	1	1	1
	1030	DZFP000732	Harness, SNS1-SNS2	C	For UF-590/790	1	1	1	1	1	1	1	1	1	1	1	1	1	1	1	1	1	1	1	1	1	1	1	1	1	
		DZFP001915		N	For UF-590/790/6000/6100	1	1	1	1	1	1	1	1	1	1	1	1	1	1	1	1	1	1	1	1	1	1	1	1	1	1
	1031	DZFP000730	Harness, SNS3-TNR	C	For UF-590	1	1	1	1	1	1	1	1	1	1	1	1	1	1	1	1	1	1	1	1	1	1	1	1	1	
		DZFP001242			For UF-580	1	1	1	1	1	1	1	1	1	1	1	1	1	1	1	1	1	1	1	1	1	1	1	1	1	1
		DZFP001913		N	For UF-790	1	1	1	1	1	1	1	1	1	1	1	1	1	1	1	1	1	1	1	1	1	1	1	1	1	1
		DZFP001927			For UF-780	1	1	1	1	1	1	1	1	1	1	1	1	1	1	1	1	1	1	1	1	1	1	1	1	1	1
	1032	DZFP001219	Harness, PSU-C-D	C	For UF-590/790	1	1	1	1	1	1	1	1	1	1	1	1	1	1	1	1	1	1	1	1	1	1	1	1	1	
		DZFP001924		N	For UF-590/790/6000/6100	1	1	1	1	1	1	1	1	1	1	1	1	1	1	1	1	1	1	1	1	1	1	1	1	1	1

Safety Mark	Ref. No.	Part Number	Part Name	New Parts	Remarks	Destination Codes																														
						AA	AB	AE	AG	AH	AJ	AK	AL	AM	AP	AR	AT	AU	AV	AW	EE	EN	YA	YC	YF	YG	YH	YJ	YM	YR	YS	YT	YV	YW	YX	
	1033	DZFP001221	Herness, PSU-T	C	For UF-590/790	1	1	1	1	1	1	1	1	1	1	1	1	1	1	1	1	1	1	1	1	1	1	1	1	1	1	1	1	1		
		DZFP001926		N	For UF-590/790/6000/6100	1	1	1	1	1	1	1	1	1	1	1	1	1	1	1	1	1	1	1	1	1	1	1	1	1	1	1	1	1	1	
	1034	DZFP000716	Harness SC-CST2	C	For UF-590/790	1	1	1	1	1	1	1	1	1	1	1	1	1	1	1	1	1	1	1	1	1	1	1	1	1	1	1	1			
		DZFP001935		N	For UF-590/790/6000/6100	1	1	1	1	1	1	1	1	1	1	1	1	1	1	1	1	1	1	1	1	1	1	1	1	1	1	1	1	1		
	1035	DZFP000717	Harness CST2-SNS2	C	For UF-590/790	1	1	1	1	1	1	1	1	1	1	1	1	1	1	1	1	1	1	1	1	1	1	1	1	1	1	1	1			
		DZFP001936		N	For UF-590/790/6000/6100	1	1	1	1	1	1	1	1	1	1	1	1	1	1	1	1	1	1	1	1	1	1	1	1	1	1	1	1	1		
	121	DZFN000066	Cord, Handset	C		-	-	1	-	-	-	1	-	-	-	-	1	1	-	-	-	-	1	1	-	1	-	-	1	-	-	1	1			
	123	DZFN000117	Cord, Cradle	C		-	-	1	-	-	-	-	-	-	-	-	1	1	-	-	-	-	1	1	-	1	-	-	1	-	-	1	1			
		DZFN000118				-	-	-	-	-	-	1	-	-	-	-	-	-	-	-	-	-	-	-	-	-	-	-	-	-	-	-	-	-		
	327	DZHP005744	Solenoid, Stamp	C	For UF-590/790	1	1	1	1	1	1	1	1	1	1	1	1	1	1	1	1	1	1	1	1	1	1	1	1	1	1	1				
					For UF-580/780	1	1	-	1	1	1	1	-	1	1	1	1	1	1	1	-	1	1	-	1	1	1	1	1	-	-	1	1	-	1	
		L9AAAABA0005		N	For UF-590/790/6000/6100	1	1	1	1	1	1	1	1	1	1	1	1	1	1	1	1	1	1	1	1	1	1	1	1	1	1	1	1	1		
	531	DZGB000039	Solenoid, Paper Feed	C	For UF-590/790	1	1	1	1	1	1	1	1	1	1	1	1	1	1	1	1	1	1	1	1	1	1	1	1	1	1	1				
					For UF-580/780	1	1	-	1	1	1	1	-	1	1	1	1	1	1	1	-	1	1	-	1	1	1	1	1	-	-	1	1	-	1	
		L9AAABCB0003		N	For UF-590/790/6000/6100	1	1	1	1	1	1	1	1	1	1	1	1	1	1	1	1	1	1	1	1	1	1	1	1	1	1	1	1	1		
	728	DZGT000022	Thermistor Assembly	C	For UF-590/790	1	1	1	1	1	1	1	1	1	1	1	1	1	1	1	1	1	1	1	1	1	1	1	1	1	1	1	1			
						For UF-580/780	1	1	-	1	1	1	1	-	1	1	1	1	1	1	1	-	1	1	-	1	1	1	1	1	-	-	1	1	-	1
						For UF-6000/6100	-	1	1	1	1	-	1	1	1	1	1	1	1	1	1	1	1	-	1	1	1	1	1	1	1	1	1	1	1	1
	908	DZGB000019	Solenoid Paper Feed	C	For UF-590/790	1	1	1	1	1	1	1	1	1	1	1	1	1	1	1	1	1	1	1	1	1	1	1	1	1	1	1	1			
		L9AAABEB0017		N	For UF-6000/6100	-	1	1	1	1	-	1	1	1	1	1	1	1	1	1	1	1	1	1	1	1	1	1	1	1	1	1	1	1		

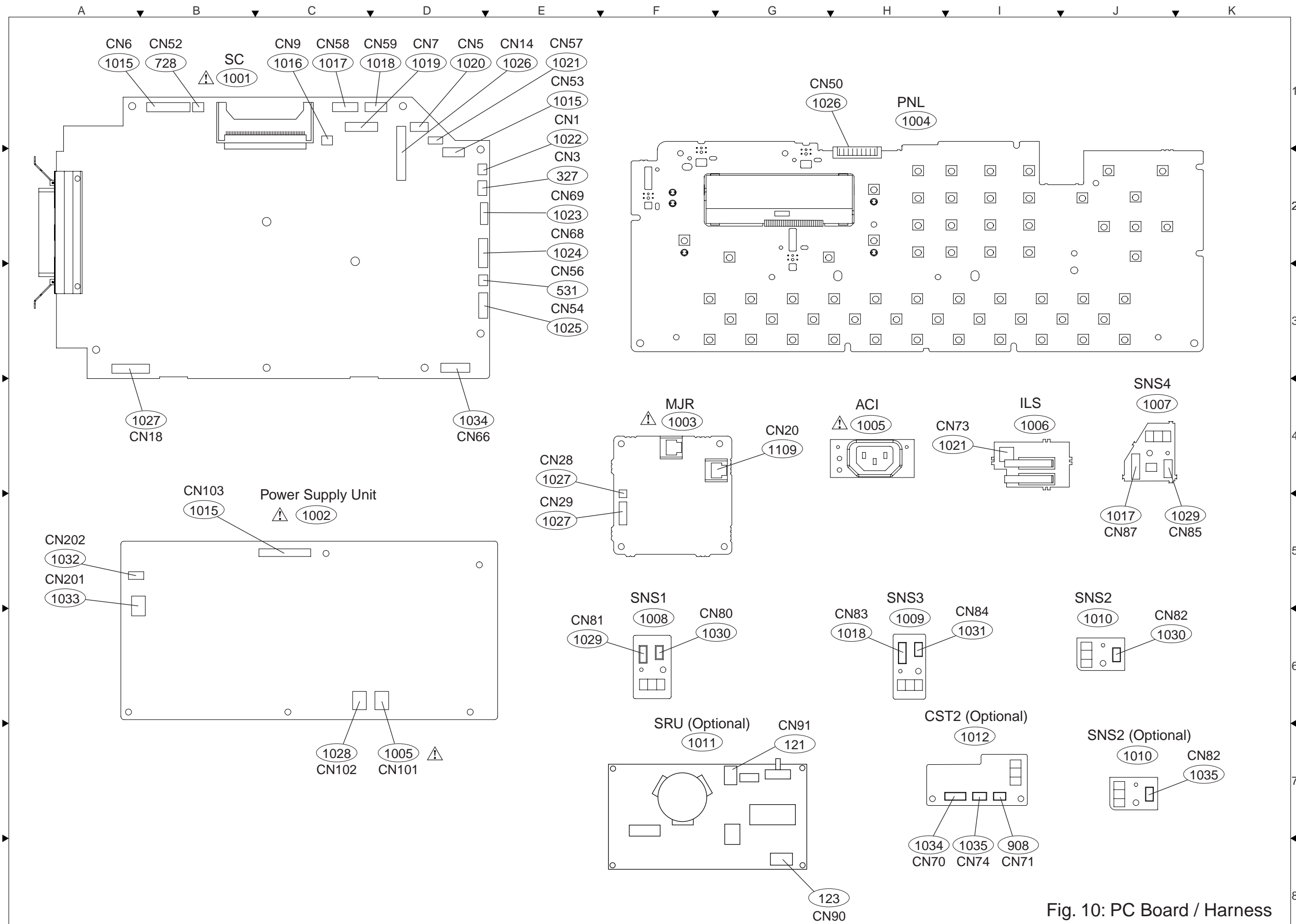

Fig. 10: PC Board / Harness









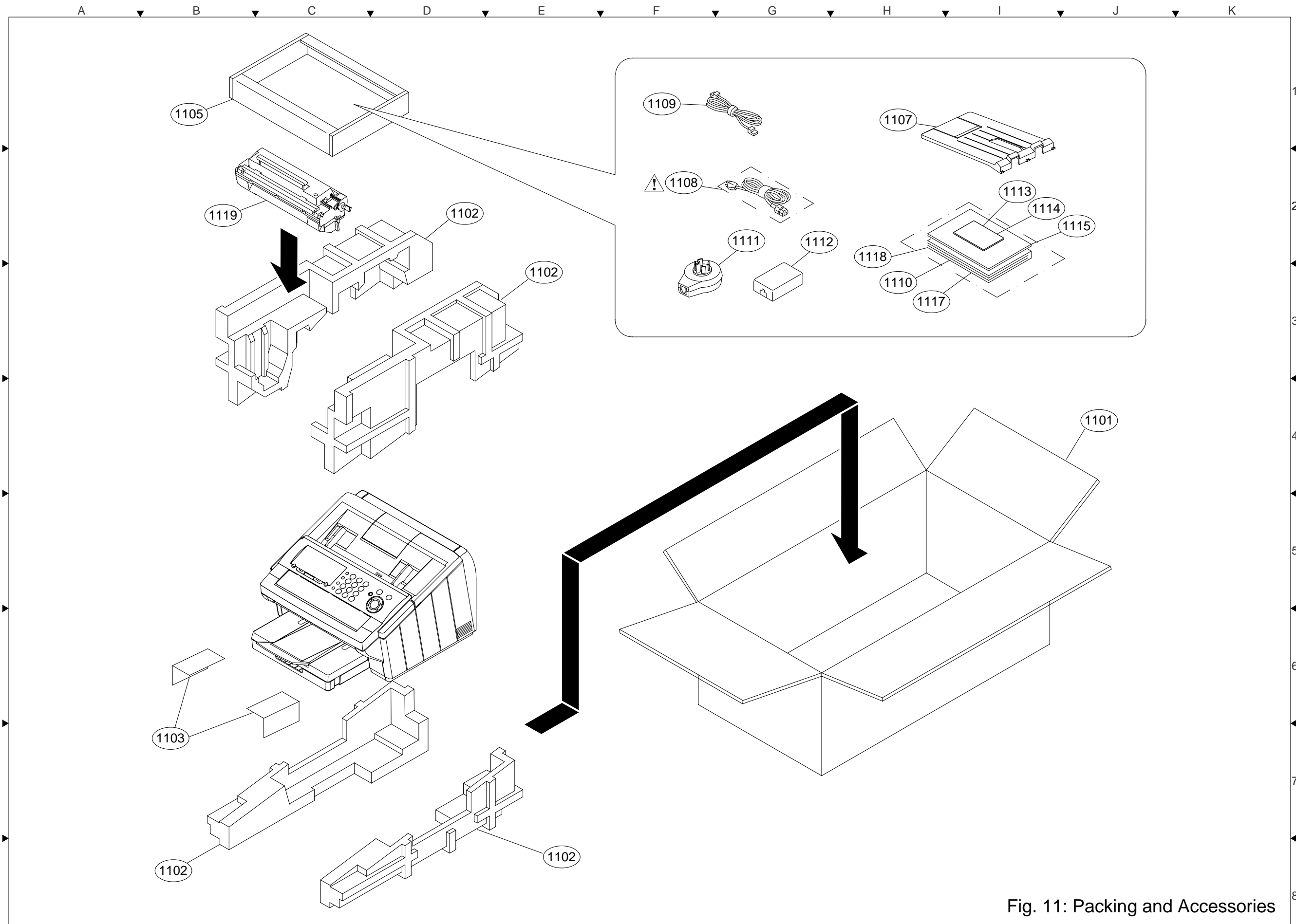

Fig. 11: Packing and Accessories

# 8 Installation

The following Instructions are examples. Please refer to the appropriate Operating Instructions for additional details.

## 8.1. Function Key

Any function can be started by first pressing **FUNCTION** and then enter the function number, or by pressing **▼** or **▲** scroll key repeatedly until the desired function appears on the display.

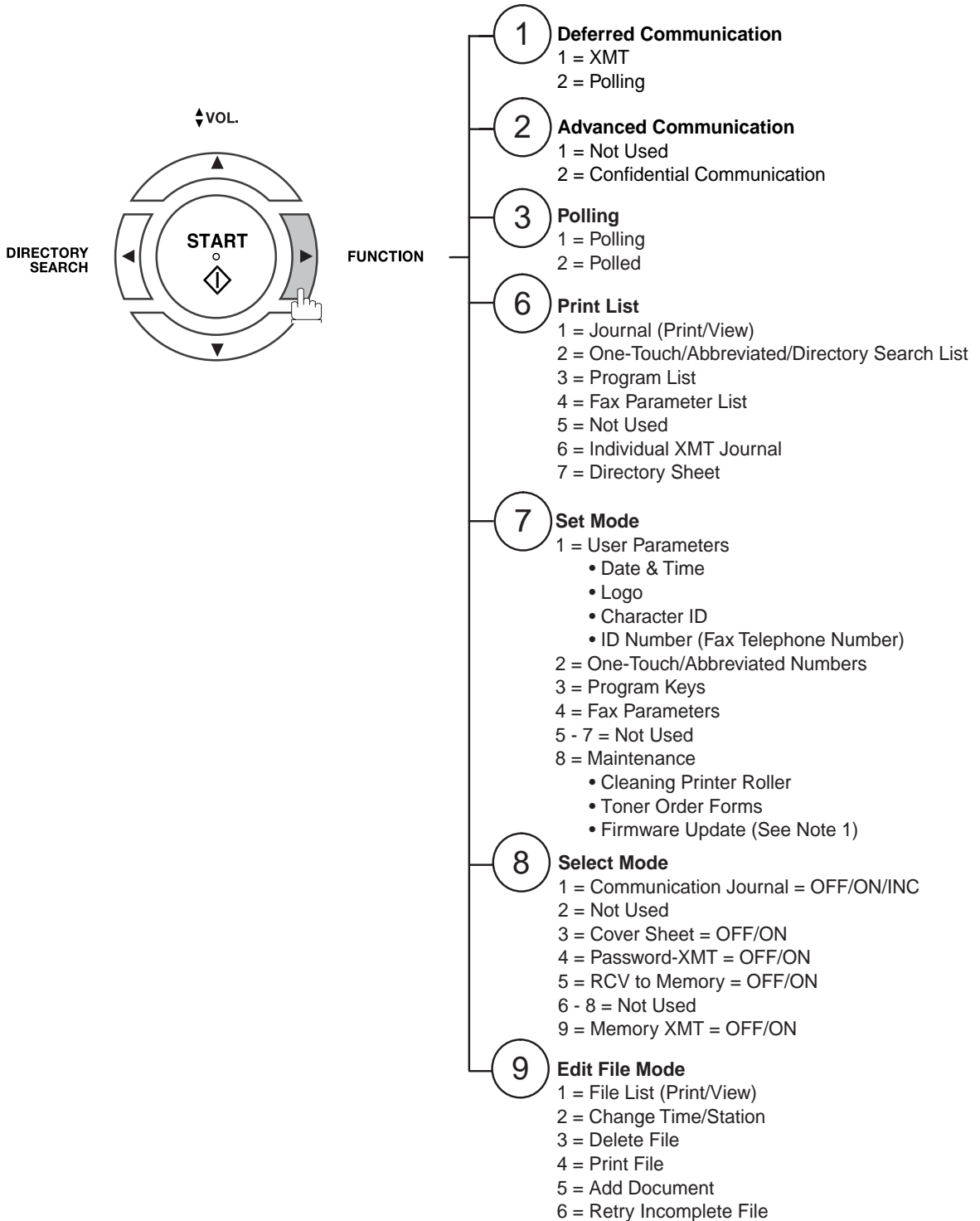

**NOTE**

1. Refer to the Firmware Update Utility's Operating Instructions on the software CD for additional details.

## 8.2. Main Unit and Accessories

Unpack the carton and check that you have all the accessories illustrated.

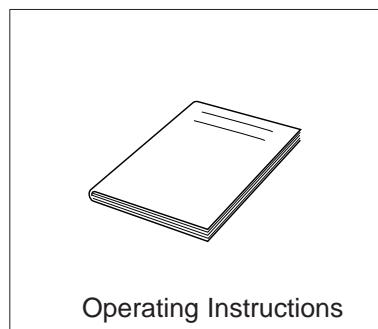
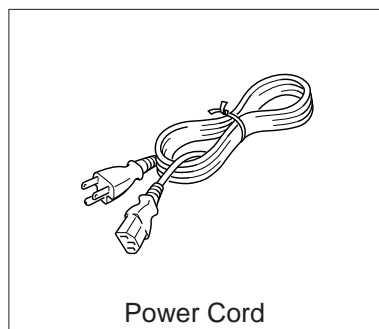
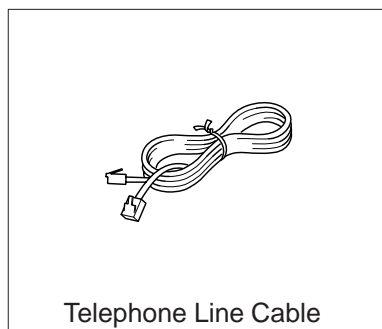
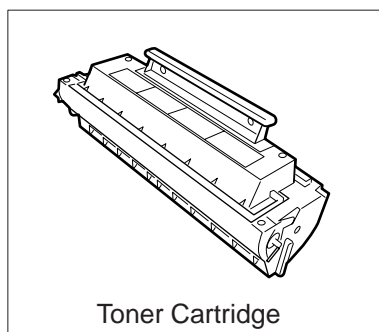
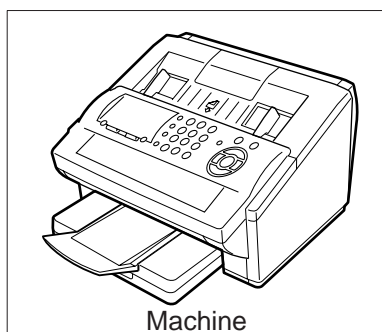

### 8.3. Installing the Accessories

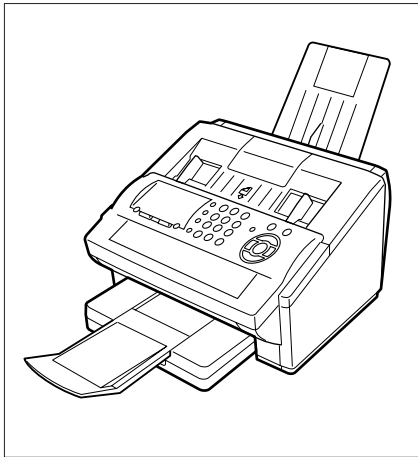

Final Installed View

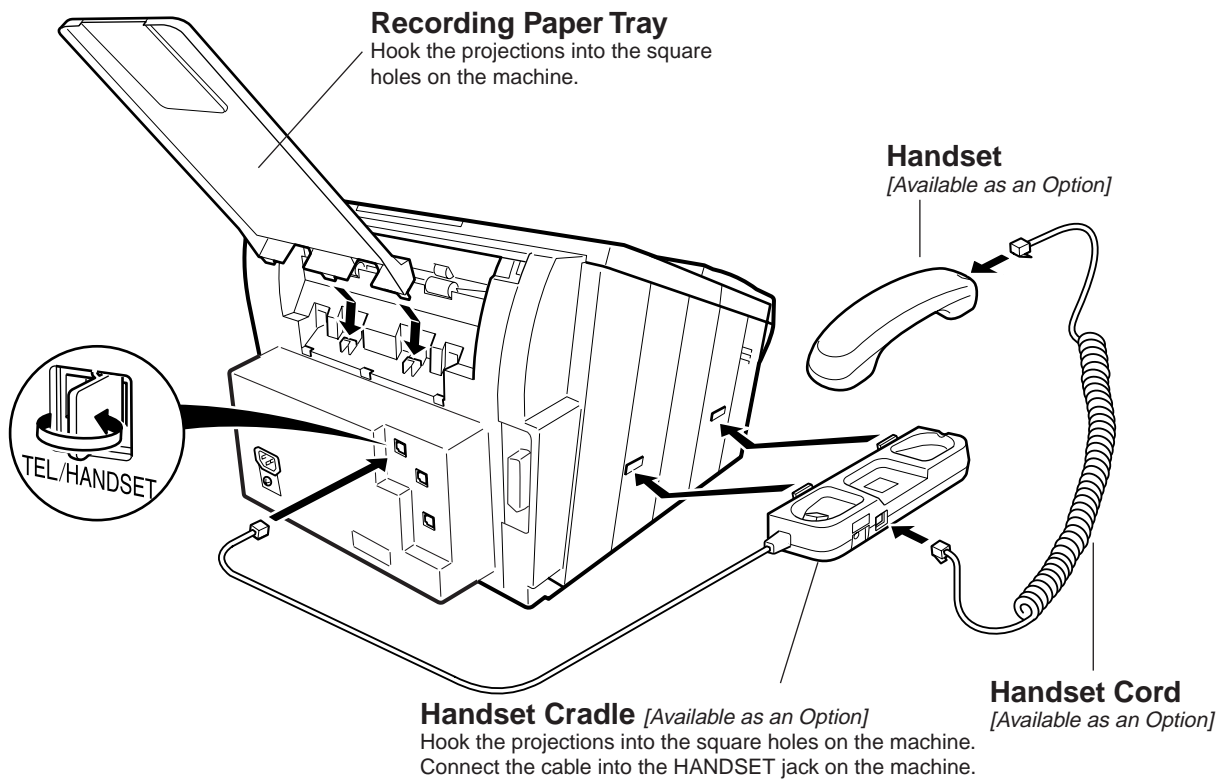

#### NOTE

The handset may not be available in certain destinations due to its regulation or specification.

## 8.4. Installing the Toner Cartridge

1

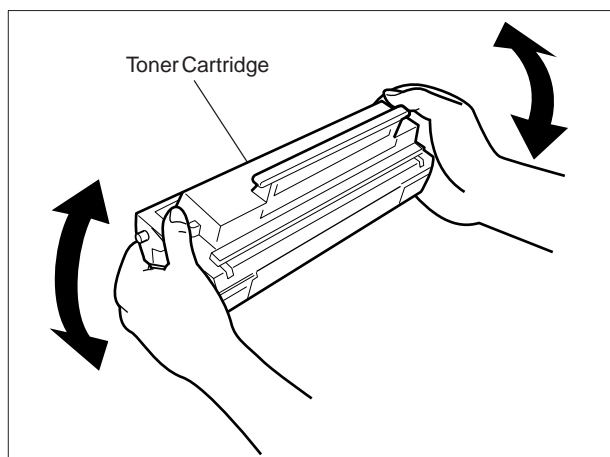

Unpack the Toner Cartridge and rock it back and forth as shown 5 or 6 times to loosen and level the toner inside.

2

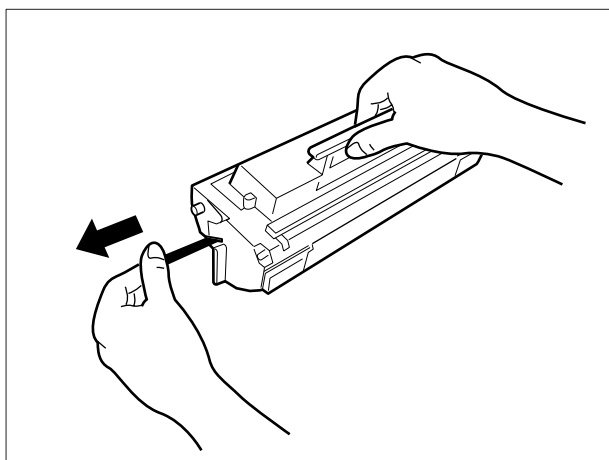

Remove the protective seal.

**Note:** Pull on the seal slowly and straight out.

3

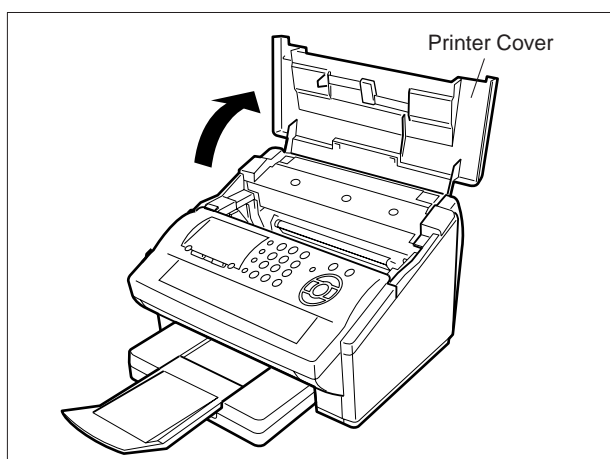

Open the Printer Cover.

*Continued on the next page...*

4

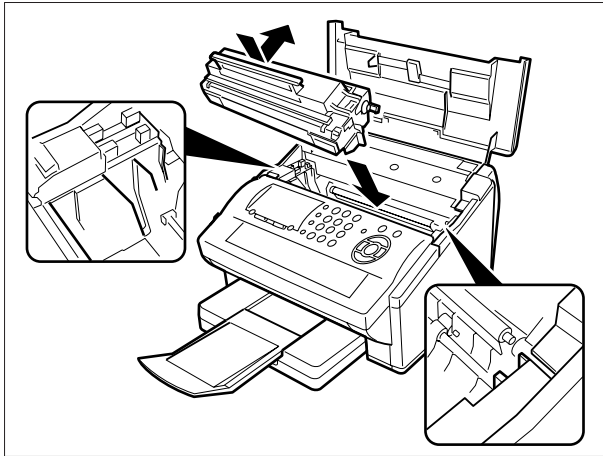

Align the projections on both sides of the Toner Cartridge with the grooves in the machine as shown and insert the Toner Cartridge into the machine.

**Note:** Lock the Toner Cartridge into place by pressing the handle down and then pushing towards the rear of the machine.

5

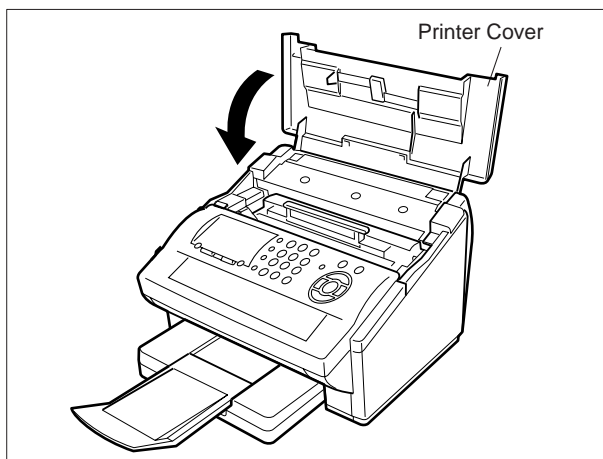

Close the Printer Cover.

6

If you are replacing the Toner Cartridge, it is recommended to clean the Printer Roller to maintain good printing quality. To clean the Printer Roller, follow the procedure on next page.

# Cleaning the Printer Roller

If you find toner on the back of the recording paper, the printer roller in the fuser unit is probably dirty.

To clean the Printer Rollers

1

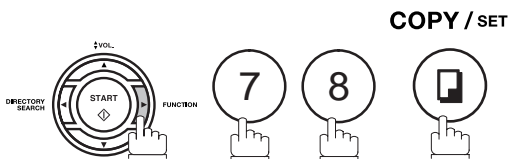

MAINTENANCE (1-9)  
ENTER NO. OR

2

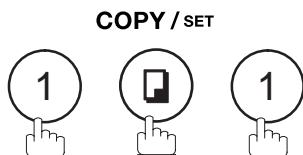

\* PRINTING \*  
CLEANING CHARTS

The machine will print out 3 Cleaning Charts.  
Then, return to standby.

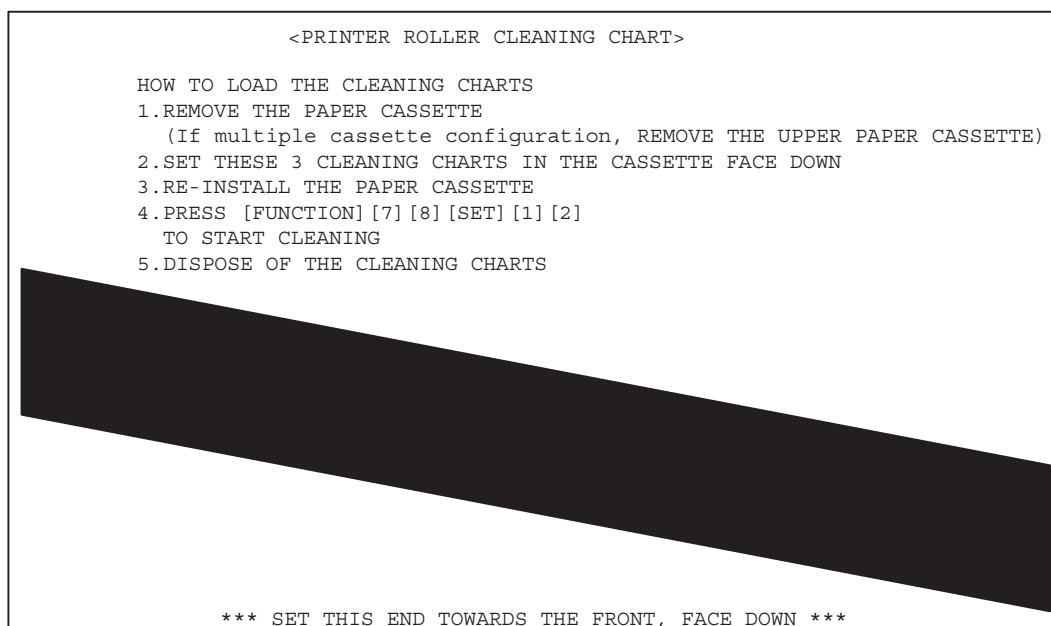

3

Load the Cleaning Charts into the cassette face down.  
(See Note 1)

4

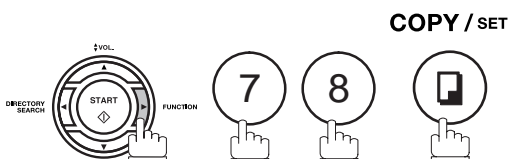

MAINTENANCE (1-9)  
ENTER NO. OR

5

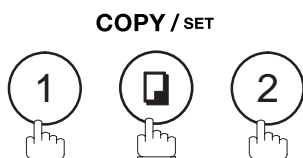

\* CLEANING \*  
PRINTER ROLLER

The Machine will feed out the charts and clean the printer roller.

## NOTE

1. If you have installed the optional cassette(s), load the Cleaning Charts into the upper cassette.



## 8.5. Loading the Recording Paper

### How to Load the Recording Paper

1

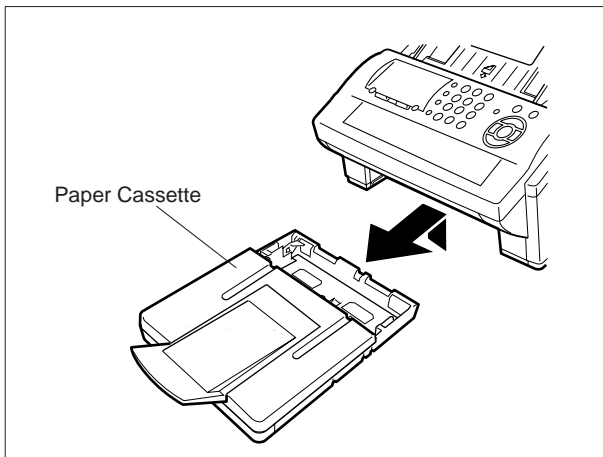

Lift up the Paper Cassette slightly and slide it out from the machine.

2

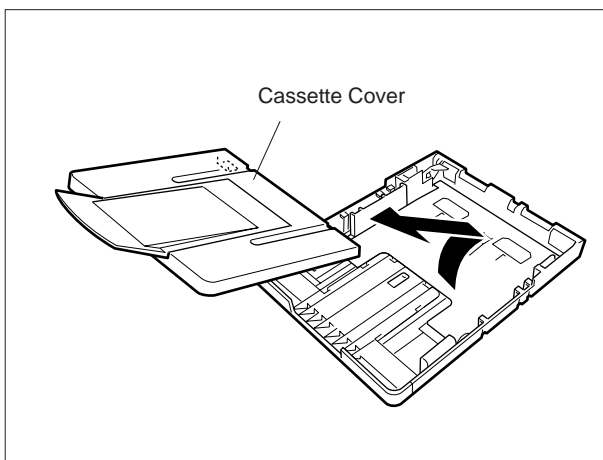

Remove the Paper Cassette Cover.

3

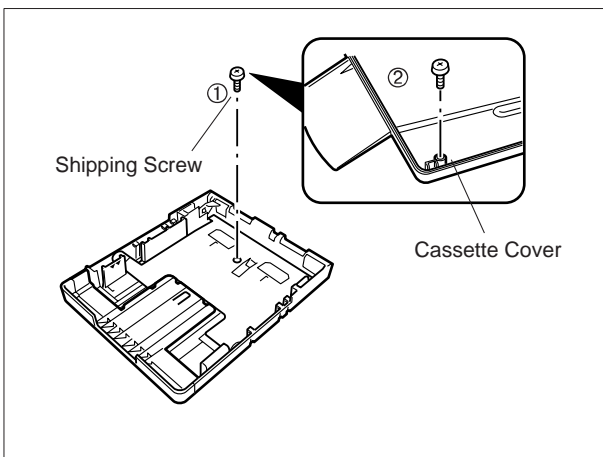

1. Remove the Shipping Screw securing the Pressure Plate.
2. Store the Shipping Screw by attaching it to the post provided under the Paper Cassette Cover for future use.

4

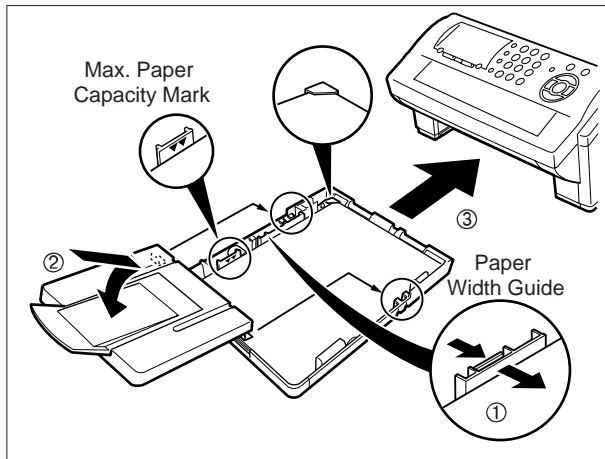

1. Load the paper into the Paper Cassette. Slide the paper width guide to the left until it lightly touches the stack of paper without bending the paper. The paper must fit squarely and firmly between the Paper Width Guide and the right side of tray. If it does not, the paper may feed into the printer incorrectly resulting in a paper jam.

**Caution:** Make sure that the paper is set under the metal Paper Separation Clips and that it does not exceed the Maximum Paper Capacity Mark. You can load about 250 sheets (20 lb weight).

2. Re-install the Paper Cassette Cover.
3. Slide the Paper Cassette into the machine.

## 8.6. Adjusting the Paper Cassette for the Paper Length

### How to Adjust the Paper Cassette for the Paper Length

The factory default Paper Length setting for the Paper Cassette is on Letter size for USA and Canada, A4 size for other destinations. To change the paper length to other size, follow the steps below.

1

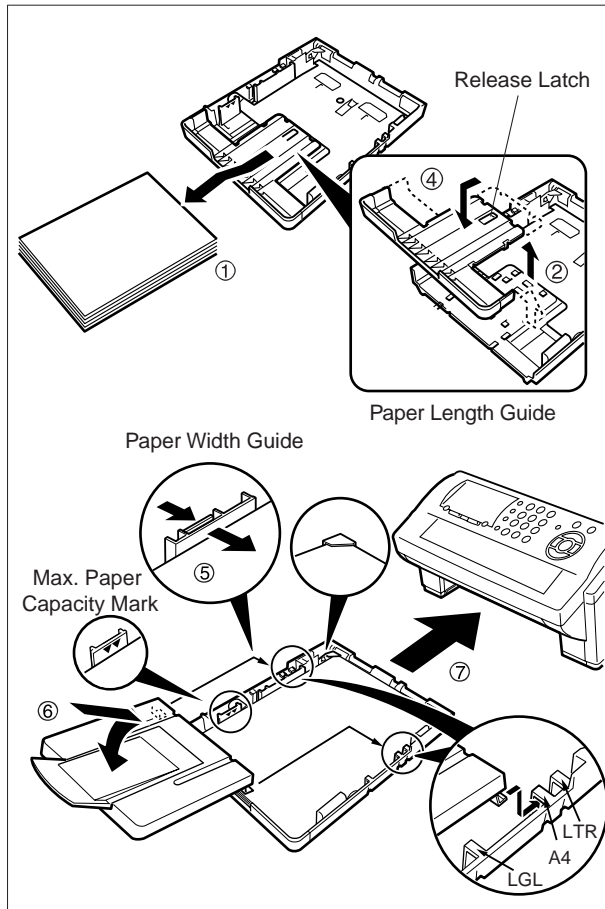

1. Remove the paper from the Paper Cassette and place the cassette upside down on a flat surface.
2. While pushing down on the release latch, pull out the Paper Length Guide.
3. Turn the Paper Cassette upright.
4. Insert the Paper Length Guide hooks into the appropriate paper length slots (A4, Letter or Legal) and slide the guide towards the back of the cassette unit it locks in place.
5. Load the paper into the Paper Cassette.

Slide the paper width guide to the left until it lightly touches the stack of paper without bending the paper. The paper must fit squarely and firmly between the Paper Width Guide and the right side of tray. If it does not, the paper may feed into the printer incorrectly resulting in a paper jam.

**Caution:** Make sure that the paper is set under the metal Paper Separation Clips and that it does not exceed the Maximum Paper Capacity Mark. You can load about 250 sheets (20 lb weight).

6. Replace the Paper Cassette Cover to the appropriate paper position (LTR, A4 or LGL).
7. Slide the Paper Cassette into the machine.

2

The Recording Paper Size setting of the Fax Parameter No. 23 must match the paper loaded in the cassette. If you change the Recording Paper Size, please change the setting accordingly.

#### NOTE

1. If you forget to change the Recording Paper Size setting in Fax Parameter No. 23 when different paper is installed in the cassette, the unit will Stop printing after the 1st page of an Incoming Fax and display a "PAPER SIZE MISMATCH" error. Then, the Recording Paper Size setting automatically adjusts to the proper size and the unit resumes printing the Incoming Fax from the 1st page.

## 8.7. Adjusting the Paper Cassette for the Paper Width

### How to Adjust the Paper Cassette for the Paper Width

The factory default Paper Width setting for the Paper Cassette is on Letter/Leagal size for USA and Canada, A4 size for other destinations. To change the paper width to other size, follow the steps below.

1

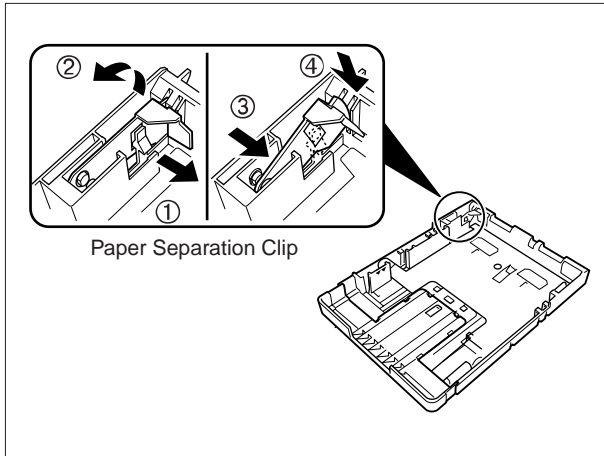

1. Release the left Paper Separation Clip latch.
2. Pull up the Paper Separation Clip to remove it.
3. Reposition the Paper Separation Clip into the A (A4) or L (Letter/Legal) slot.
4. Swing the Paper Separation Clip downward to latch it in place.

2

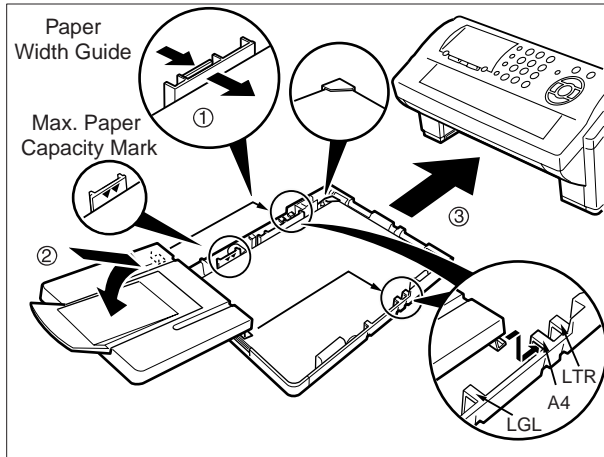

1. Load the paper into the Paper Cassette. Slide the paper width guide to the left until it lightly touches the stack of paper without bending the paper. The paper must fit squarely and firmly between the Paper Width Guide and the right side of tray. If it does not, the paper may feed into the printer incorrectly resulting in a paper jam.

**Caution:** Make sure that the paper is set under the metal Paper Separation Clips and that it does not exceed the Maximum Paper Capacity Mark. You can load about 250 sheets (20 lb weight).

2. Replace the Paper Cassette Cover to the appropriate paper position (LTR, A4 or LGL).
3. Slide the Paper Cassette into the machine.

3

The Recording Paper Size setting of the Fax Parameter No. 23 must match the paper loaded in the cassette. If you change the Recording Paper Size, please change the setting accordingly.

#### NOTE

1. If you forget to change the Recording Paper Size setting in Fax Parameter No. 23 when different paper is installed in the cassette, the unit will Stop printing after the 1st page of an Incoming Fax and display a "PAPER SIZE MISMATCH" error. Then, the Recording Paper Size setting automatically adjusts to the proper size and the unit resumes printing the Incoming Fax from the 1st page.

## 8.8. Connecting the Telephone Line Cable and Power Cord

### Power Cord

Plug one end of the power cord into an ordinary 3 prong AC outlet and the other end into the receptacle on the rear of the machine.

**Warning: This apparatus must be properly grounded through an ordinary 3 prong AC outlet. Do not break off the earth (ground) prong to fit a 2 prong outlet.**

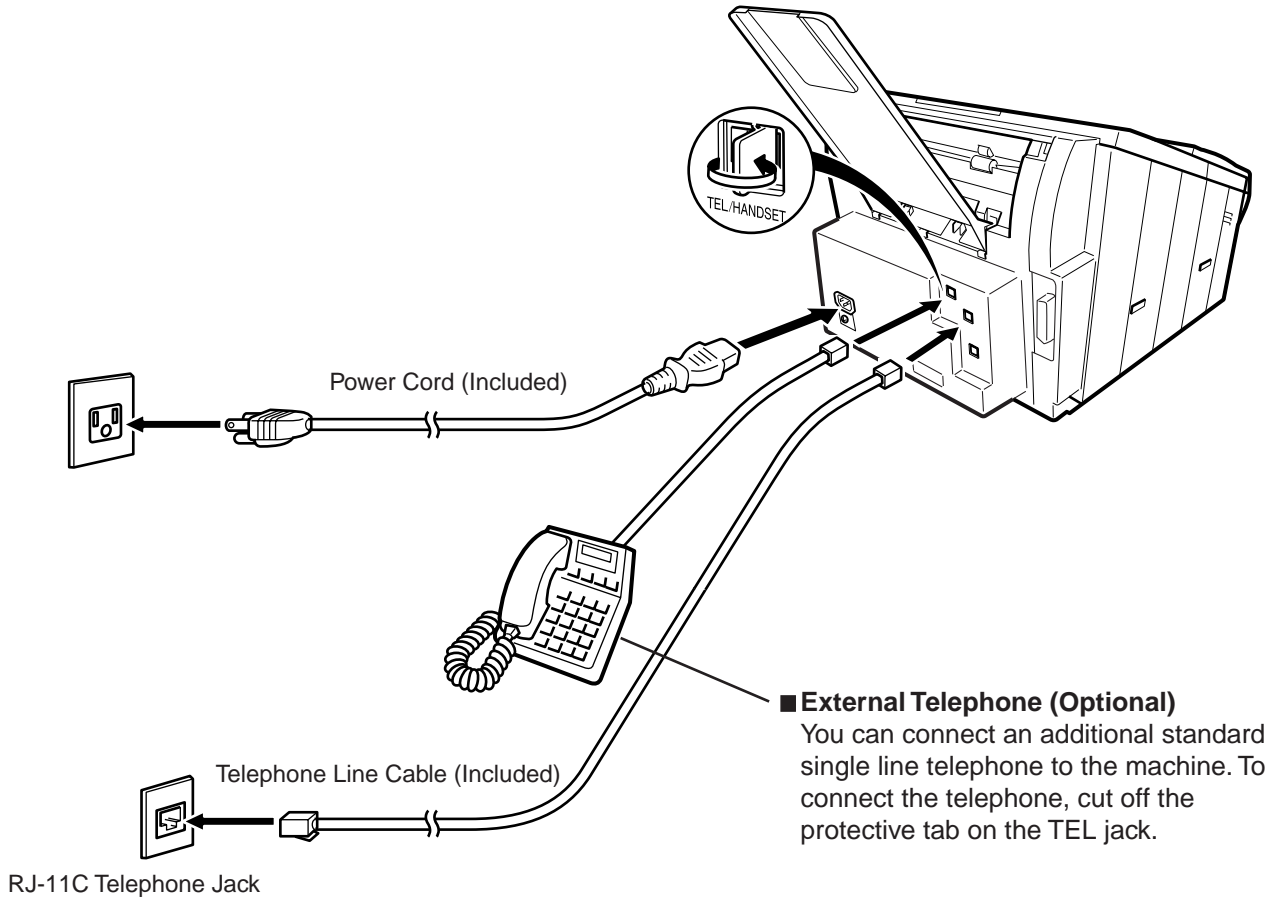

### Telephone Line Cable

Plug one end of the telephone line cable into the "RJ-11C" telephone jack supplied by the telephone company and the other end into the LINE jack on the left side of the machine.

### NOTE

1. Your machine uses little power and you should keep it ON at all times. If the power is turned OFF for too long, the clock contents may be lost.

## 8.9. Customizing Your Machine

### General Description

Your facsimile machine has a variety of adjustable Fax Parameters. These parameters, listed in the Parameter Table, are preset for you and do not need to be changed. If you do want to make a change, read the table carefully. Some parameters, such as the Resolution and Contrast parameters, can be temporarily changed by simple key operation just before a transmission is made. When the transmission ends, however, these parameters return to their preset values (Home position). Other parameters can only be changed by the procedure described below.

### Setting the Fax Parameters

1

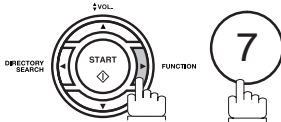

```
SET MODE      (1-8)
ENTER NO. OR ∨ ^
```

2

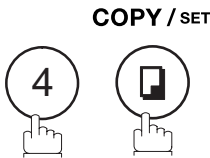

```
FAX PARAMETER(01-174)
NO. = ■
```

3

Enter Fax Parameter number from the Parameter Table.  
Ex: ① ① for **CONTRAST**

```
FAX PARAMETER(01-174)
NO. = 01
```

4



```
01 CONTRAST
1 : NORMAL
```

5

Enter the new setting value.  
Ex: ② for **LIGHTER**

```
01 CONTRAST
2 : LIGHTER
```

6



```
02 RESOLUTION
1 : STANDARD
```

To set another parameter, press **CLEAR** to return to step 3 or press **STOP** to return to standby.

#### NOTE

1. To scroll the Fax Parameters in Step 2 or 4, press ▼ or ▲.

## Fax Parameter Table

No.	Parameter	Setting Number	Setting	Comments
01	CONTRAST	*1	Normal	Setting the home position of the CONTRAST key.
		2	Lighter	
		3	Darker	
02	RESOLUTION	*1	Standard	Setting the home position for the RESOLUTION.
		2	Fine	
		3	S-Fine	
		4	Halftone (Fine)	
		5	Halftone (S-Fine)	
04	STAMP	*1	Off	Setting the home position of the STAMP key. To select the stamp function when document is stored in memory, see Fax Parameter No. 28.
		2	On	
05	MEMORY	1	Off	Setting the home position for memory transmission/copy mode. (This setting can be temporarily changed by using F8-9 (MEMORY XMT))
		*2	On	
06	DIALING METHOD	1	Pulse	Selecting the dialing method.
		*2	Tone	
07	HEADER PRINT	*1	Inside	Selecting the printing position of the header. <b>Inside</b> : Inside TX copy area. <b>Outside</b> : Outside TX copy area. <b>No print</b> : Header is not printed.
		2	Outside	
		3	No print	
08	HEADER FORMAT	*1	Logo, ID No.	Selecting the header format.
		2	From To	
09	RCV'D TIME PRINT	*1	Invalid	Selecting whether the machine prints the received date & time, remote ID, percentage of reduction and page number on the bottom of each received page.
		2	Valid	
10	KEY/BUZZER VOLUME	1	Off	Selecting the volume of the Key/Buzzer tone.
		*2	Soft	
		3	Loud	
12	COMM. JOURNAL	1	Off	Selecting the home position of printout mode for COMM. Journal Off/Always/INC. <b>Off</b> : Does not print <b>Always</b> : Always prints <b>Inc. only</b> : Prints only when communication has failed.
		2	Always	
		*3	Inc. only	
13	AUTO JOURNAL PRINT	1	Invalid	Selecting whether the machine prints the journal automatically after every 32 transactions.
		*2	Valid	
17	RECEIVE MODE	1	TEL	Setting the receive mode.
		*2	FAX	
		3	FAX/TEL SW.	
		4	TAM/FAX	

No.	Parameter	Setting Number	Setting	Comments
18	OPERATOR CALL TIMER	*1	20 sec.	Selecting the length of time that your machine signals (rings) for an incoming voice call in Fax/Tel Auto Switching mode.
		2	30 sec.	
		3	40 sec.	
		4	50 sec.	
19	OGM LENGTH (TAM I/F)	1	1 sec.	Setting for the OGM length of your TAM from 1 to 60 seconds. The machine will not start to detect SILENCE until the time setting has lapsed. (Default = 20 sec.)
		---	---	
		60	60 sec.	
20	SILENT DETECTION (TAM I/F)	1	Invalid	Selecting the Silent Detection Mode.
		*2	Valid	
22	SUBSTITUTE RCV	1	Invalid	Selecting whether the machine receives to memory when recording paper runs out, toner runs out or recording paper is jammed.
		*2	Valid	
23	RECORDING PAPER SIZE	1	A4	Setting the recording paper size installed in your machine.
		*2	Letter	
		3	Legal	
24	PRINT REDUCTION	1	Fixed	Selecting print reduction mode. <b>Fixed</b> : Reduce received document according to setting of Parameter No. 25. <b>Auto</b> : Reduce received document according to the length of received documents.
		*2	Auto	
25	REDUCTION RATIO	70	70%	Selecting fixed print reduction ratio from 70% to 100%. This parameter functions only when fixed print reduction is selected on Fax Parameter No. 24.
		----	----	
		*100	100%	
26	POLLING PASSWORD		(----	Setting a 4-digit password for secured polling.
27	POLLED FILE SAVE	*1	Invalid	Selecting whether the machine retains the polled document in memory even after the document is polled once.
		2	Valid	
28	STAMP AT MEM. XMT	1	Invalid	Selecting whether the machine stamps the original documents when storing the documents into memory. (Depending on the Stamp setting on the Control Panel)
		*2	Valid	
31	INCOMPLETE FILE SAVE	*1	Invalid	Selecting whether the machine retains the document in memory if the document is not successfully transmitted.
		2	Valid	
32	COPY REDUCTION	1	Manual	Selecting whether the machine performs the copy reduction ratio automatically or manually. <b>Manual</b> : The machine will prompt you for the Zoom ratio (100% to 70%) when making copies. <b>Auto</b> : The machine will automatically determine the reduction ratio according to the length of the original document.
		*2	Auto	



No.	Parameter	Setting Number	Setting	Comments
34	ENERGY SAVER MODE	1	Off	To reduce the power consumption in standby, select either Energy-Saver or Sleep mode and specify the Delay Time (1 to 120 minutes) for the machine to enter into the selected mode. The Delay Timer setting is only available in the Energy-Saver or Sleep Modes. <b>Off</b> : The unit will remain in standby mode and consume more energy than when in Energy-Saver or Sleep modes. <b>Energy-Saver Mode</b> : Saves energy by consuming less power than when in standby mode by turning off the fuser unit after the specified time. <b>Sleep Mode</b> : This is the lowest power state that the machine enters after the specified time without actually turning off.
		2	Energy-Saver	
		*3	Sleep	
35	DAYLIGHT TIME	1	Invalid	Selecting whether the clock adjusts for Daylight Saving Time automatically. The built-in clock will advance 1 hour at 2:00 am on the first Sunday in April and fallback 1 hour at 2:00 am on the last Sunday in October.
		*2	Valid	
36	RING PATTERN DETECT (DRD) (See Note 2)	*1	Invalid	All ring patterns.
		2	Valid	Select a ring pattern for automatic answering. <b>1:</b> A Standard ring pattern. <b>2:</b> B Double ring pattern. <b>3:</b> C Triple ring pattern (Short-Short-Long). <b>4:</b> D All other triple ring patterns, except the type C described above.
37	RCV TO MEMORY		(----	Enter a 4-digit password used to print out the received document in memory by using F8-5 (RCV TO MEMORY). When F8-5 is set to On, this parameter will not be shown on the LCD display.
38	ACCESS CODE		(----	Enter a 4-digit Access Code to secure the machine from unauthorized use.
39	PIN CODE ACCESS	*1	None	Selecting the access method (Prefix or Suffix) to dial a number with PIN Code.
		2	Suffix	
		3	Prefix	
42	CONF. POLLED FILE SAVE	*1	Invalid	Selecting whether the machine saves the confidential polled file even after the file is polled once.
		2	Valid	
43	PASSWORD-XMT	*1	Off	Setting a 4-digit XMT-Password and selecting whether the machine performs and checks the XMT-Password of the receiving station when transmitting.
		2	On	
44	PASSWORD-RCV	*1	Off	Setting a 4-digit RCV-Password and selecting whether the machine performs and checks the RCV-Password of the transmitting station when receiving.
		2	On	
46	SELECT RCV	*1	Invalid	Selecting whether the machine performs selective reception.
		2	Valid	
47	REMOTE RECEPTION	1	Invalid	Selecting whether or not the machine accepts remote reception command.
		*2	Valid	
51	REMOTE DIAGNOSTIC	*1	Invalid	Selecting whether or not the machine accepts to update the firmware or Remote Diagnostics from the remote station. Please ask your Panasonic Authorized Dealer for details.
		2	Valid	

No.	Parameter	Setting Number	Setting	Comments
52	DIAGNOSTIC PASSWORD		(----	Setting the password for Remote Diagnostic Mode. Please ask your Panasonic Authorized Dealer for details.
53	SUB-ADDRESS PASSWORD		(----	Setting a 20-digit password for secured sub-address communication.
54	FAX FORWARD	*1	Invalid	Selecting whether the machine performs Fax Forwarding to the specified destination.
		2	Valid	
56	COVER SHEET	*1	Off	Setting the home position of the Cover Sheet parameter in the Select Mode.
		2	On	
58	LANGUAGE	*1	A-English	Selecting the language to be shown on the display and reports.
		2	C-French	
		3	Spanish	
63	PC-FAX RCV MODE (Except UF-580/780)	*1	Print	Selecting how the machine will execute the received Fax document(s). If the setting is set to either "Upload" or "Upload & Print" the machine cannot enter the Sleep Mode. <b>Print</b> : Print the received document(s). <b>Upload &amp; Print</b> : Print the received document(s) and upload it's file. <b>Upload</b> : Upload the received document file.
		2	Upload & Print	
		3	Upload	
65	PRINT COLLATION	1	Invalid	Selecting whether the machine prints out documents in sequence.
		*2	Valid	
82	QUICK MEMORY XMT	1	Invalid	Selecting whether the machine performs Quick Memory Transmission. <b>Invalid</b> : Stores all documents into memory first before dialing the telephone number. <b>Valid</b> : Starts dialing the telephone number immediately after storing the first page.
		*2	Valid	
99	MEMORY SIZE (Flash Memory)	-	-	Displays the amount of base and optional memory installed. (Base Memory + Optional Memory)

## NOTE



1. Setting number marked with an asterisk (\*) indicates the factory standard setting.
2. This parameter supports an optional telephone service "Distinctive Ring Service" provided by your local telephone company. It allows up to 4 different telephone numbers to be assigned on a single telephone line with a distinctive ring for each telephone number. By selecting the appropriate ring pattern associated with the telephone number assigned for your fax machine. It can differentiate and answer the incoming call on the fax number. All other calls on the other telephone numbers will not be answered. This optional service from your local phone company is also called Custom Ringing, Distinctive Ringing, Ident-a-call, Ident-a-ring, Personalized Ringing, RingMaster, RingMate, Selective Ringing, Smart Ring or something similar. Check with your local telephone company on the availability of this service in your area.

## 9 Options and Supplies

### 9.1 Options and Supplies

Please contact your local Panasonic dealer for availability.

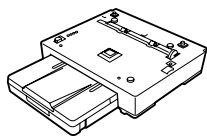
#### 1. Options

Order No.	Picture	Description
UE-403176		Handset Kit
UE-409070		250 Sheet Letter / Legal / A4 Size Paper Cassette with the Feeder Unit (Not available for UF-580/780/5000)
UE-410046		Expansion Flash Memory Card, 2 MB
UE-410047		Expansion Flash Memory Card, 4 MB
UE-410048		Expansion Flash Memory Card, 8 MB

#### 2. Supplies

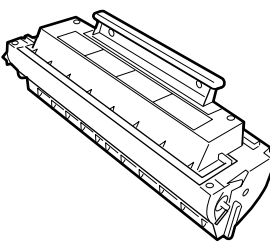
Order No.	Picture	Description
DZHT000027 (For USA / Canada)		Verification Stamp
DZHT000004		
UG-5510 (For USA / Canada)		Toner Cartridge
UG-3350		

**Note:**

For some destinations, the Handset Kit may not be available because of the destination's regulation or specification.

## 9.2 Installing Optional 250 Sheet Paper Cassette (UE-409070)

### 1. Contents

Qty.	Description	Part No.	Remarks
1	250 Sheet Paper Cassette with Feeder Unit	UE-409070	

### 2. Installation

**Note:**

Install this Feeder Unit as the 2nd Feeder Unit only.

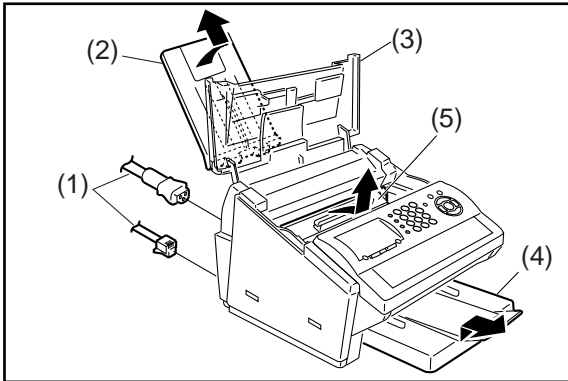

- (1) Disconnect the **Telephone Line Cable** (1009) and the **Power Cord** (1008).
- (2) Remove the **Recording Paper Tray Assembly** (1107).
- (3) Open the **Printer Cover** (106).
- (4) Remove the **Paper Cassette** from the machine.
- (5) Remove the **Toner Cartridge** from the machine.

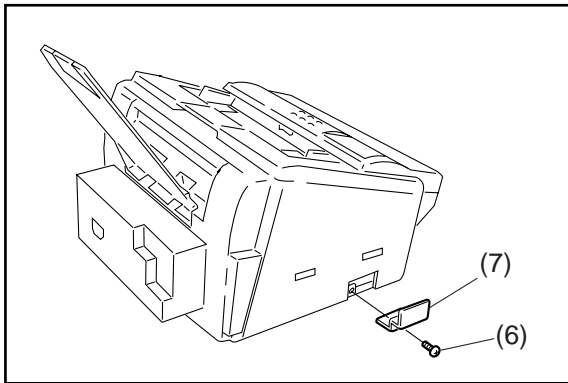

- (6) Remove 1 **Screw** (B1).
- (7) Remove the **Connector Access Cover** (114).

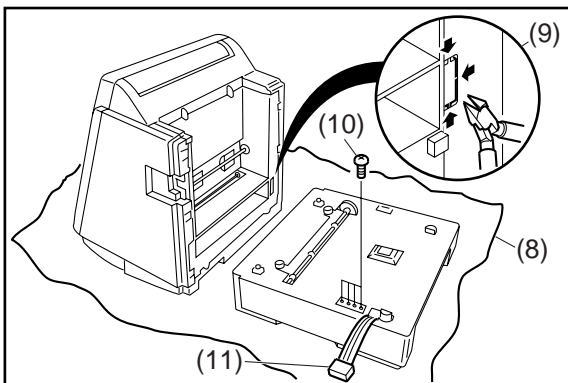

- (8) Place the machine on its Rear side over a clean cloth to prevent damaging the Rear Cover.
- (9) Break off the protective tab on the machine.
- (10) Remove 4 **Screws** from the top of the 250 Sheet Paper Cassette.
- (11) Remove the shipping tape and place the **CST2-SNS2 Harness** (1035) to the outside of the cassette.

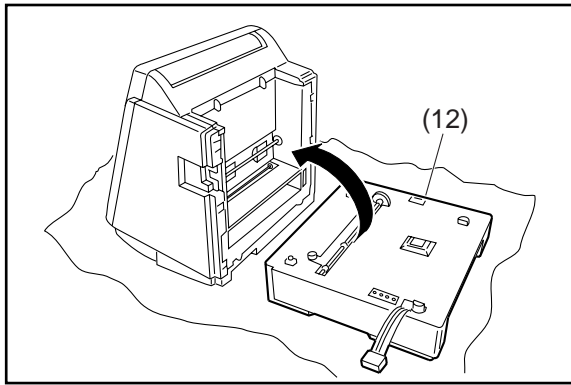

(12) Insert the 250 Sheet Paper Cassette into the machine.

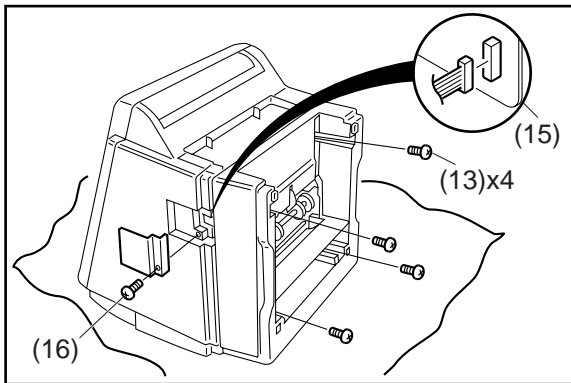

(13) Secure the 250 Sheet Paper Cassette with the 4 screws removed in step 10.

(14) Place the machine upright.

(15) Connect the **CST2-SNS2 Harness** (1035) into the **Connector CN66** on the SC PC Board.

(16) Re-install the **Connector Access Cover** (114).

(17) Re-install the **Recording Paper Tray Assembly** (1107), **Paper Cassettes** and the **Toner Cartridge**.

(18) Re-connect the **Telephone Line Cable** (1109) and the **Power Cord** (1108).

(19) Print some pages from the Optional Paper Cassette to confirm its operation.

## 9.3 Installing Handset Kit (UE-403176)

### 1. Contents

Qty.	Description	Part No.	Remarks
1	Handset	DZDU000031	
1	Handset Cord	DZFN000066	
1	Cradle Assembly	DZML000436	

### 2. Installation

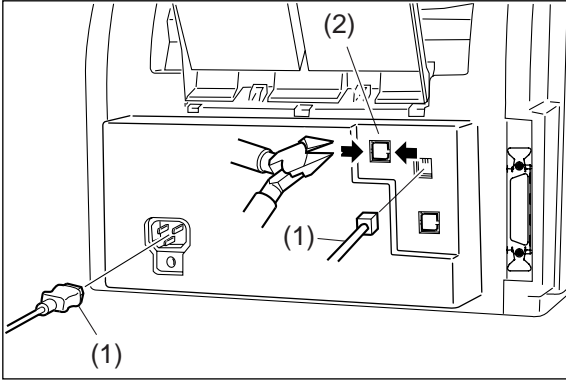

- (1) Disconnect the **Power Cord** (1108) and the **Telephone Line Cable** (1109).
- (2) Break off the protective tab on the **TEL/HANDSET Jack** on the machine.

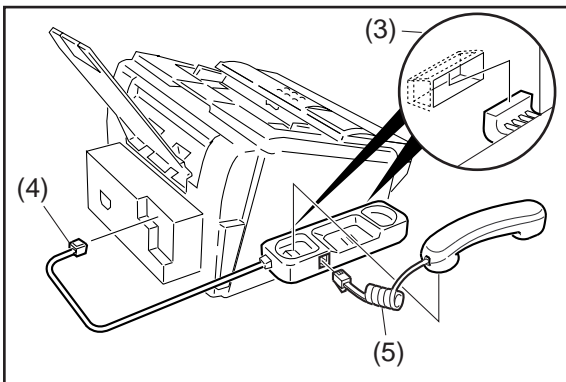

- (3) Hook the projections of the Cradle Assembly into the holes on the Left Cover.
- (4) Connect the **Cradle Cable** (123) to the **TEL/HANDSET Jack** on the rear of the machine.
- (5) Connect the **Handset Cable** (121).
- (6) Re-connect the **Telephone Line Cable** (1109) and the **Power Cord** (1108).

# 10 Schematic Diagram

## 10.1. General Circuit Diagram

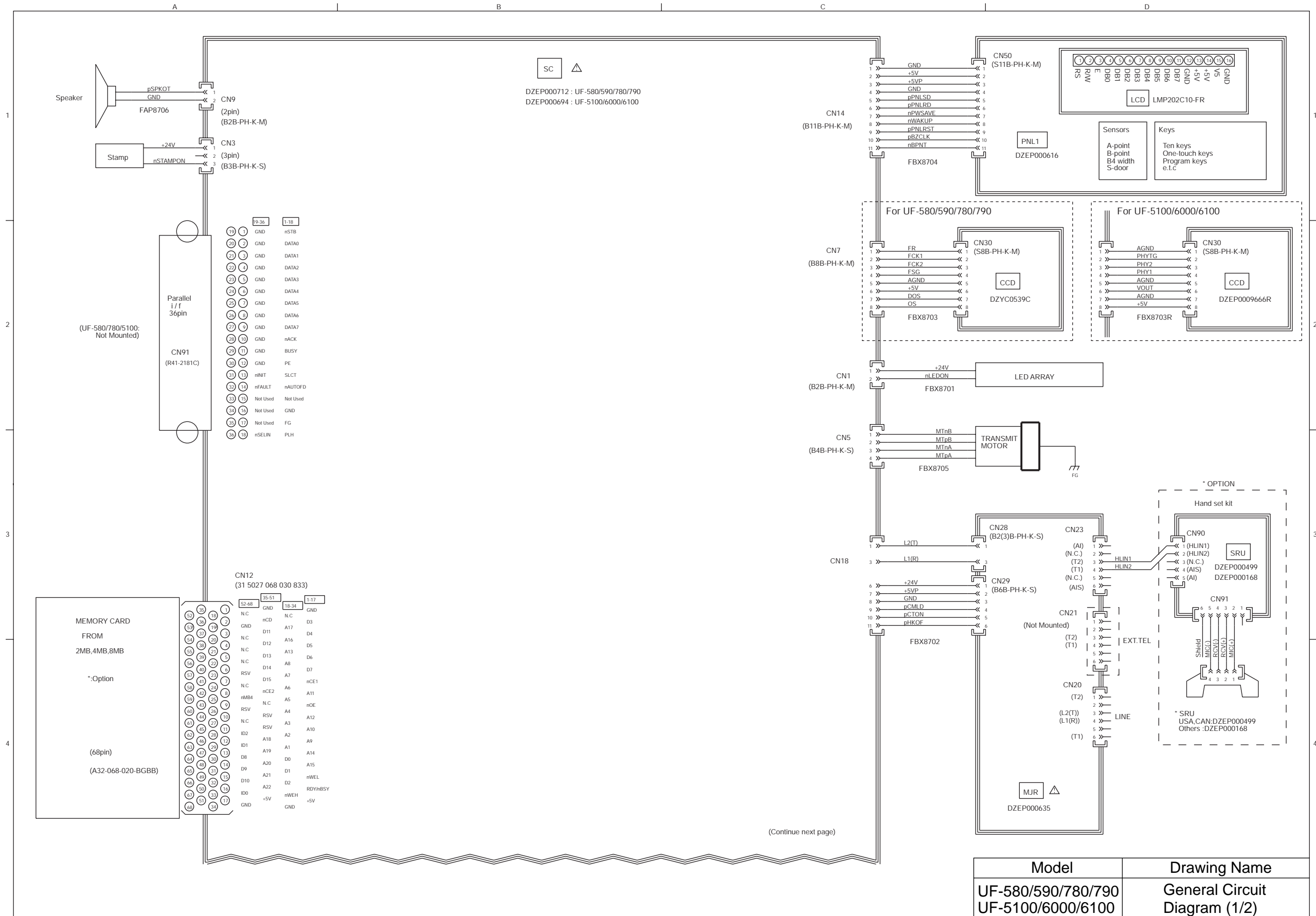

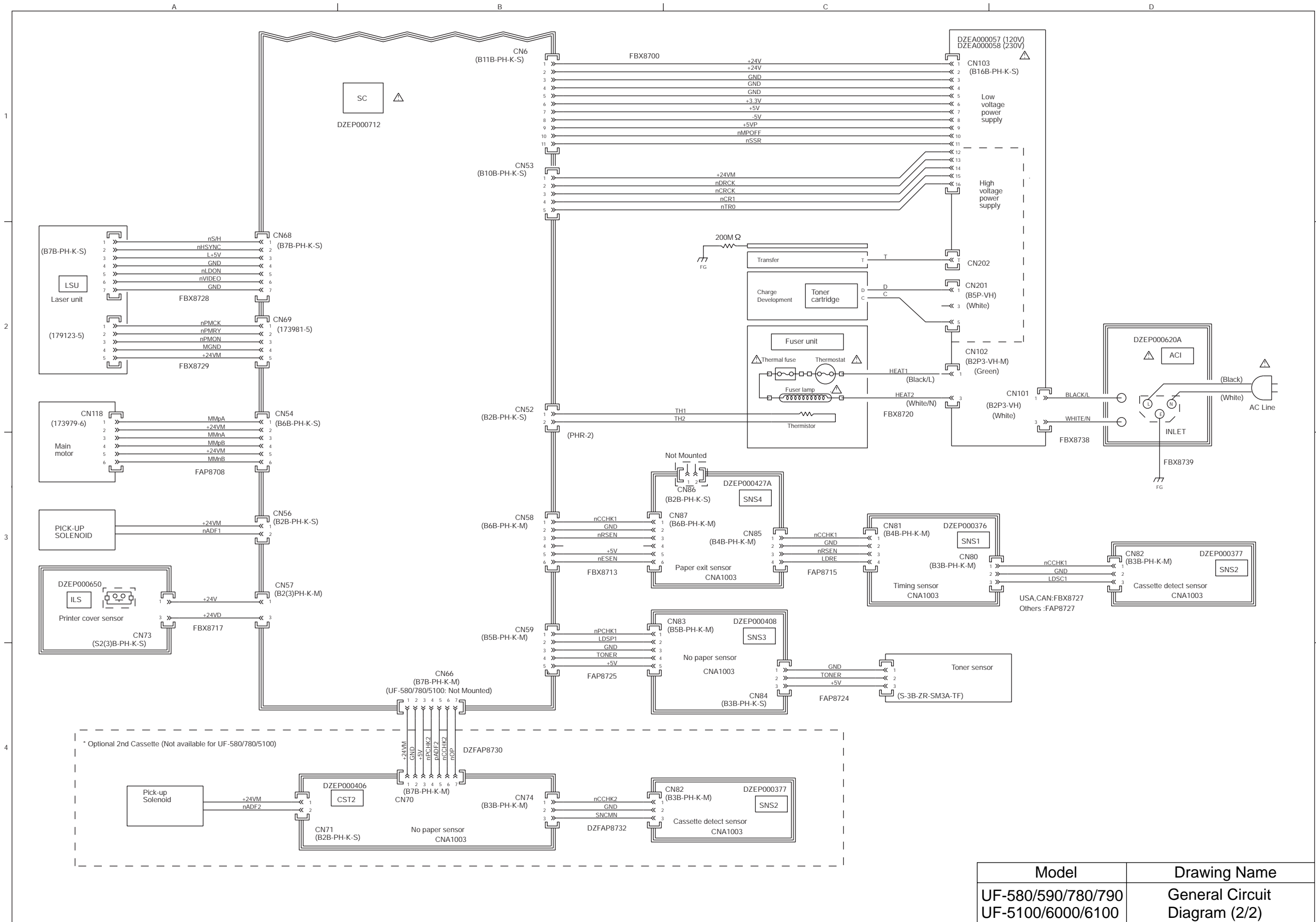



# 10.2. SC PC Board (For UF-580/590/780/790)

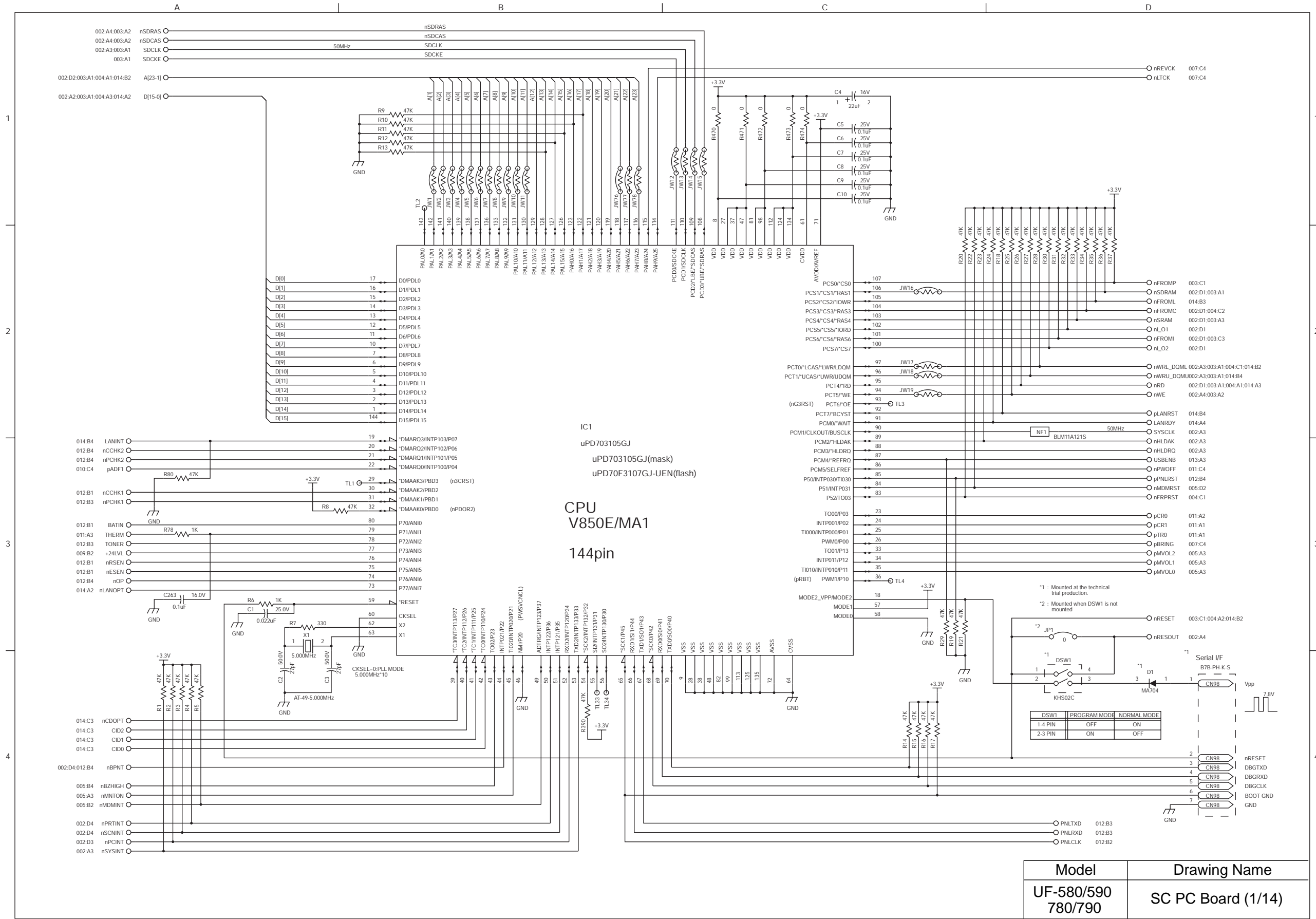

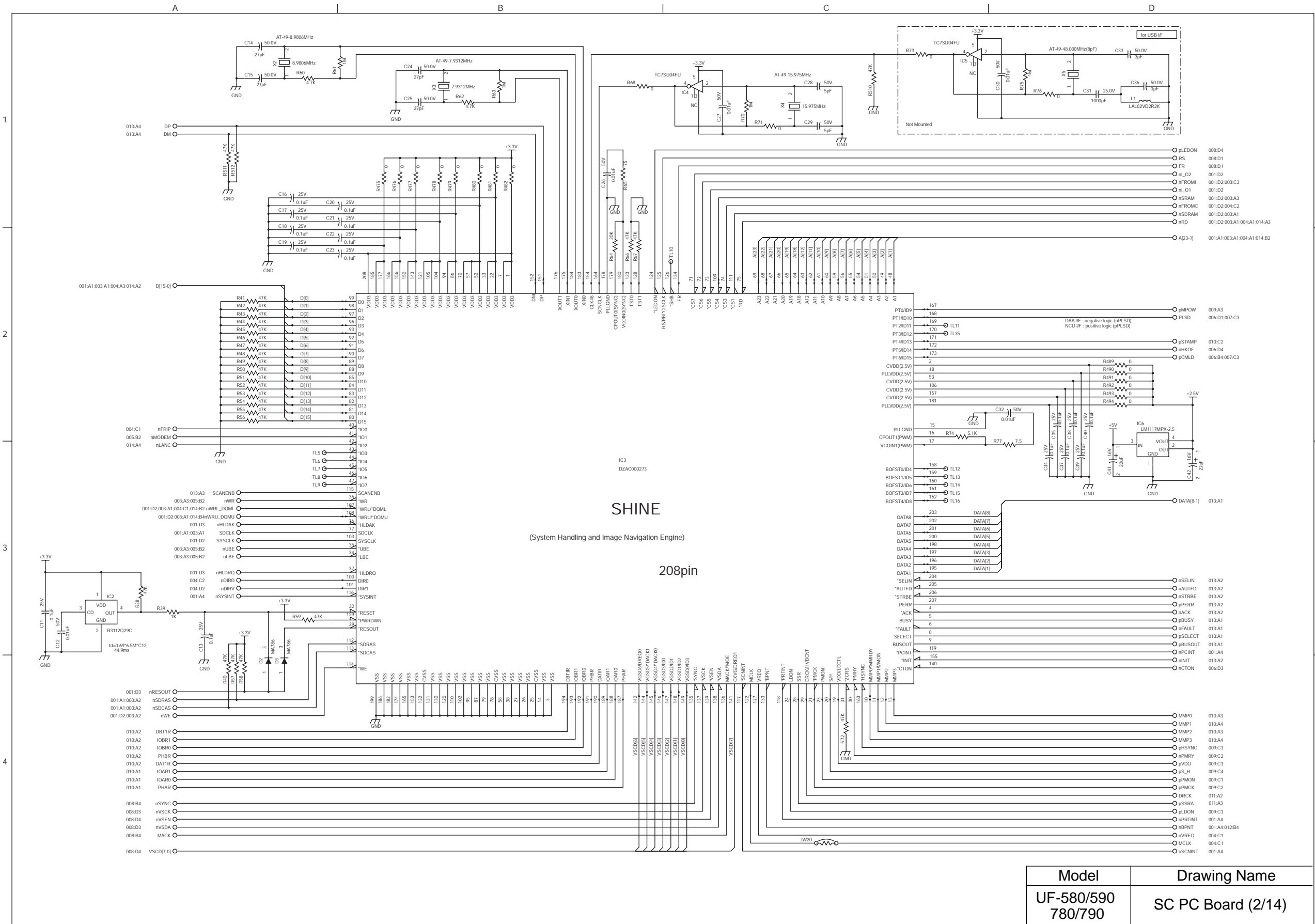

Model	Drawing Name
UF-580/590 780/790	SC PC Board (2/14)

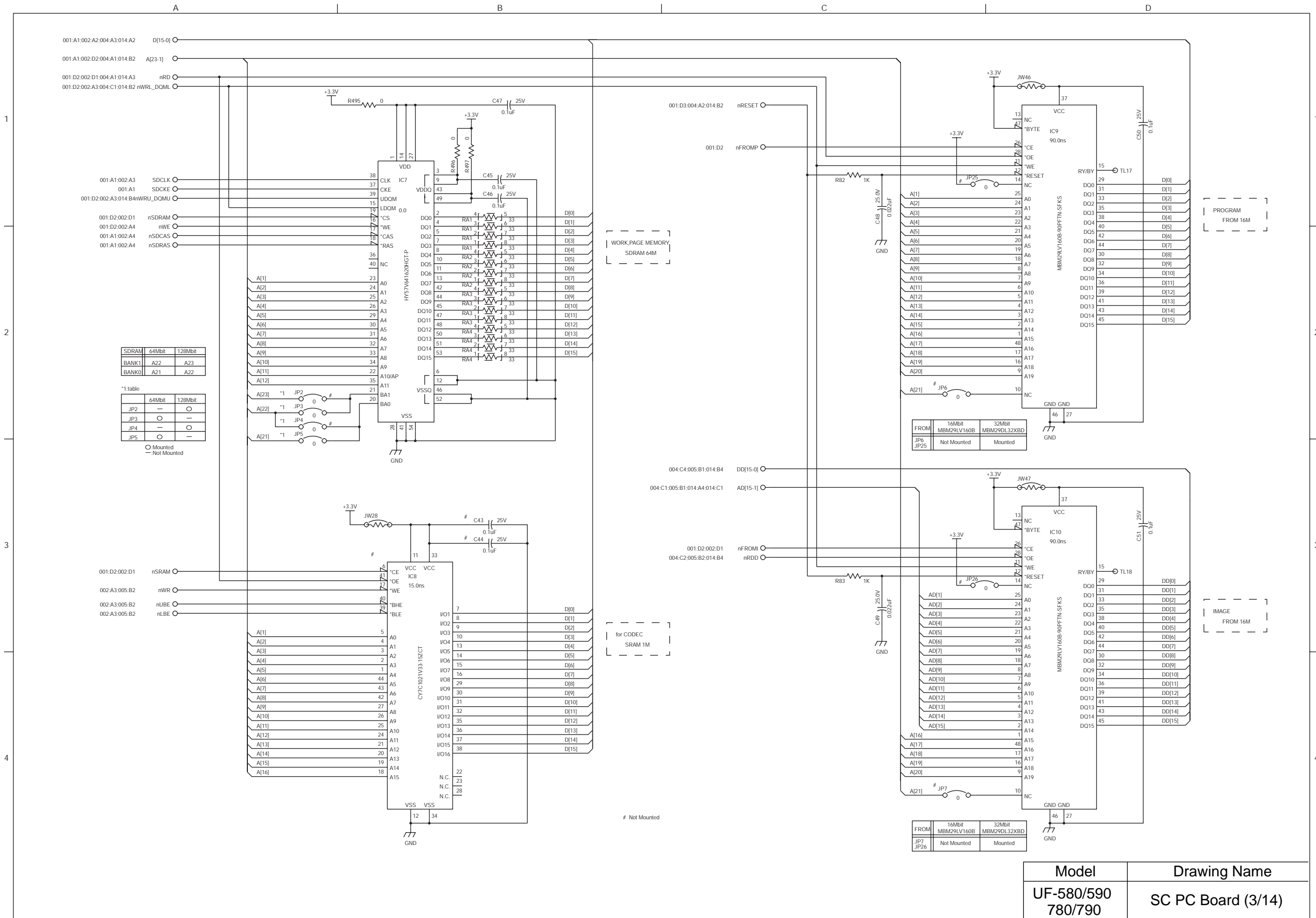

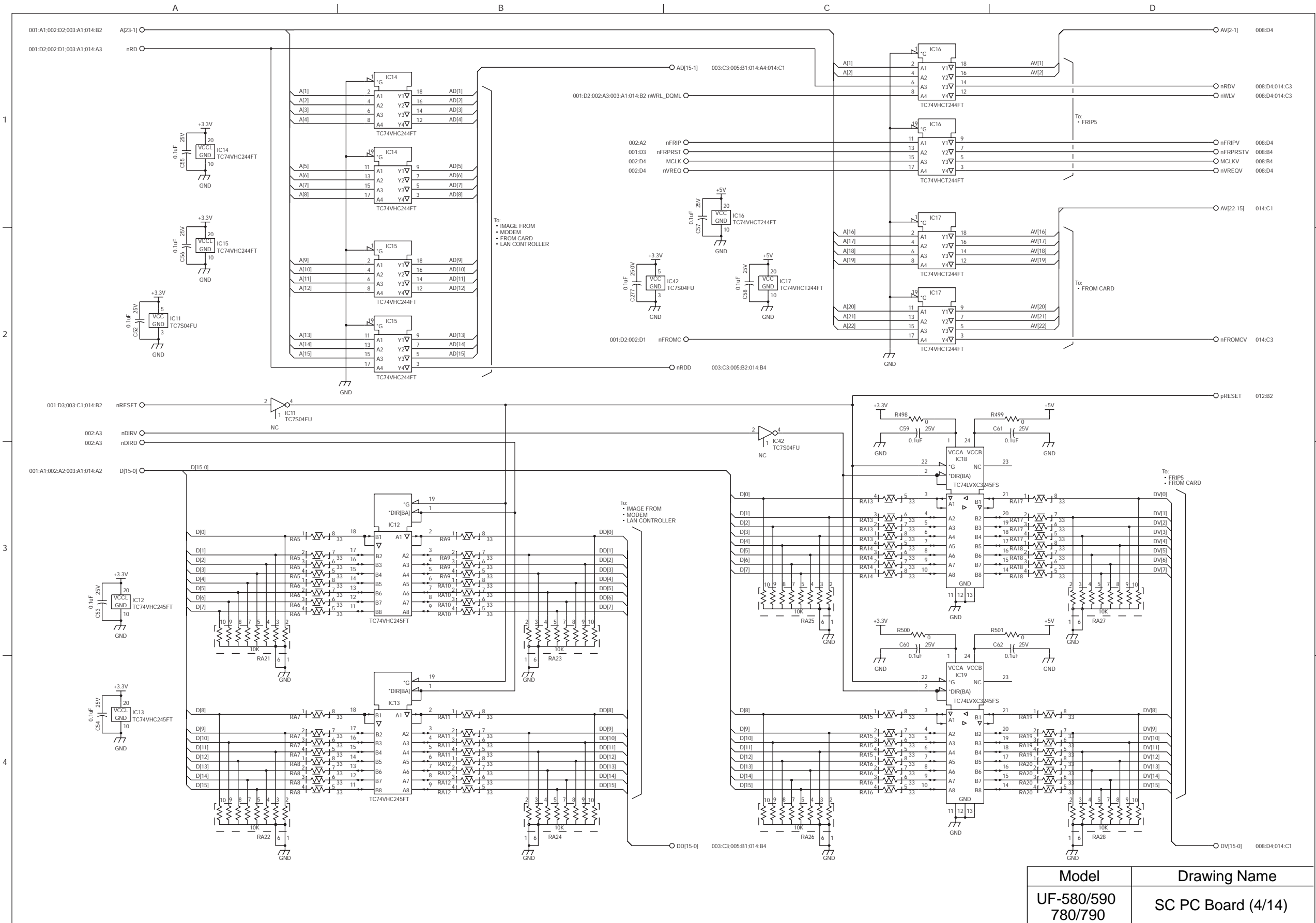

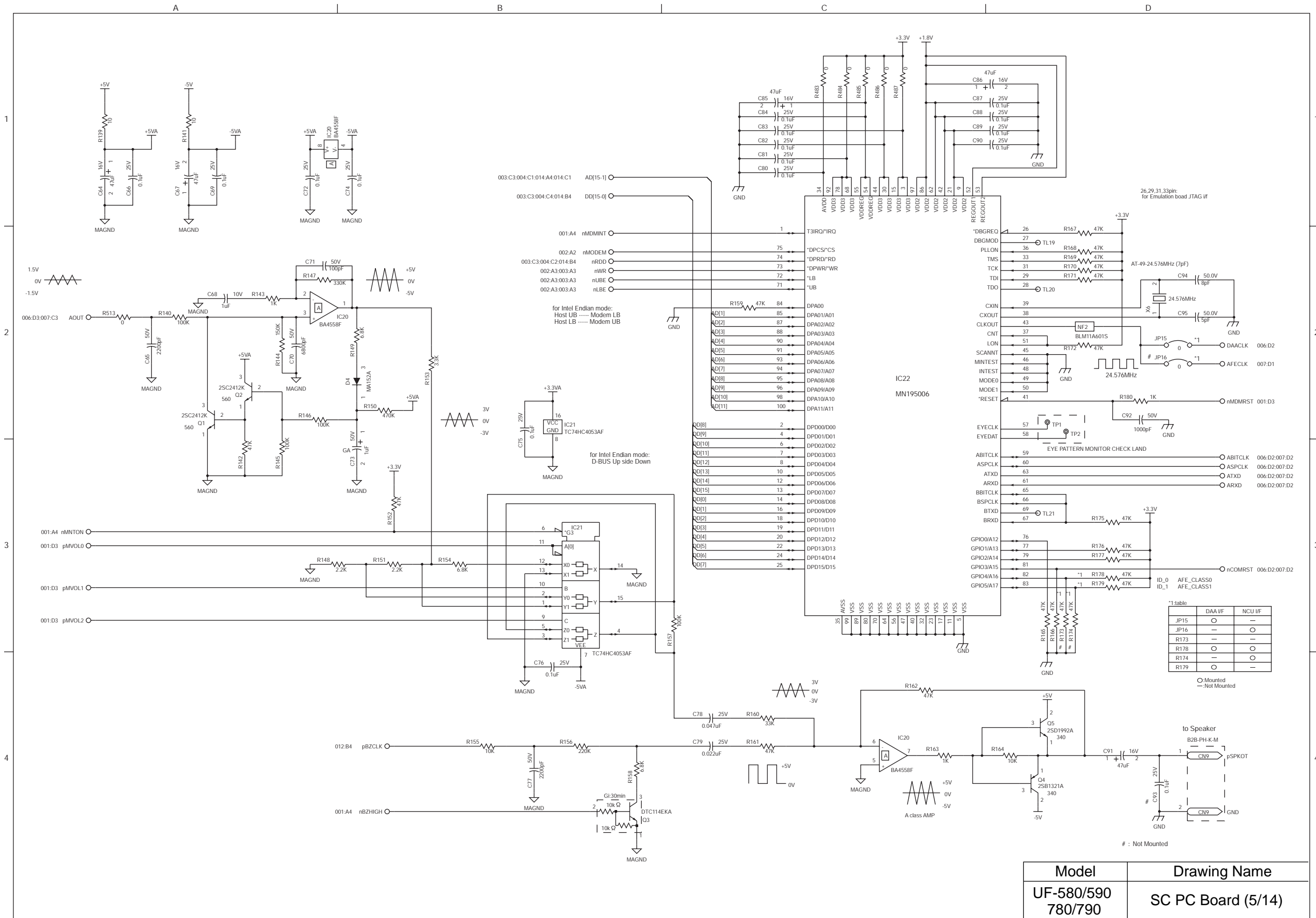

Model	Drawing Name
UF-580/590	SC PC Board (5/14)
780/790	

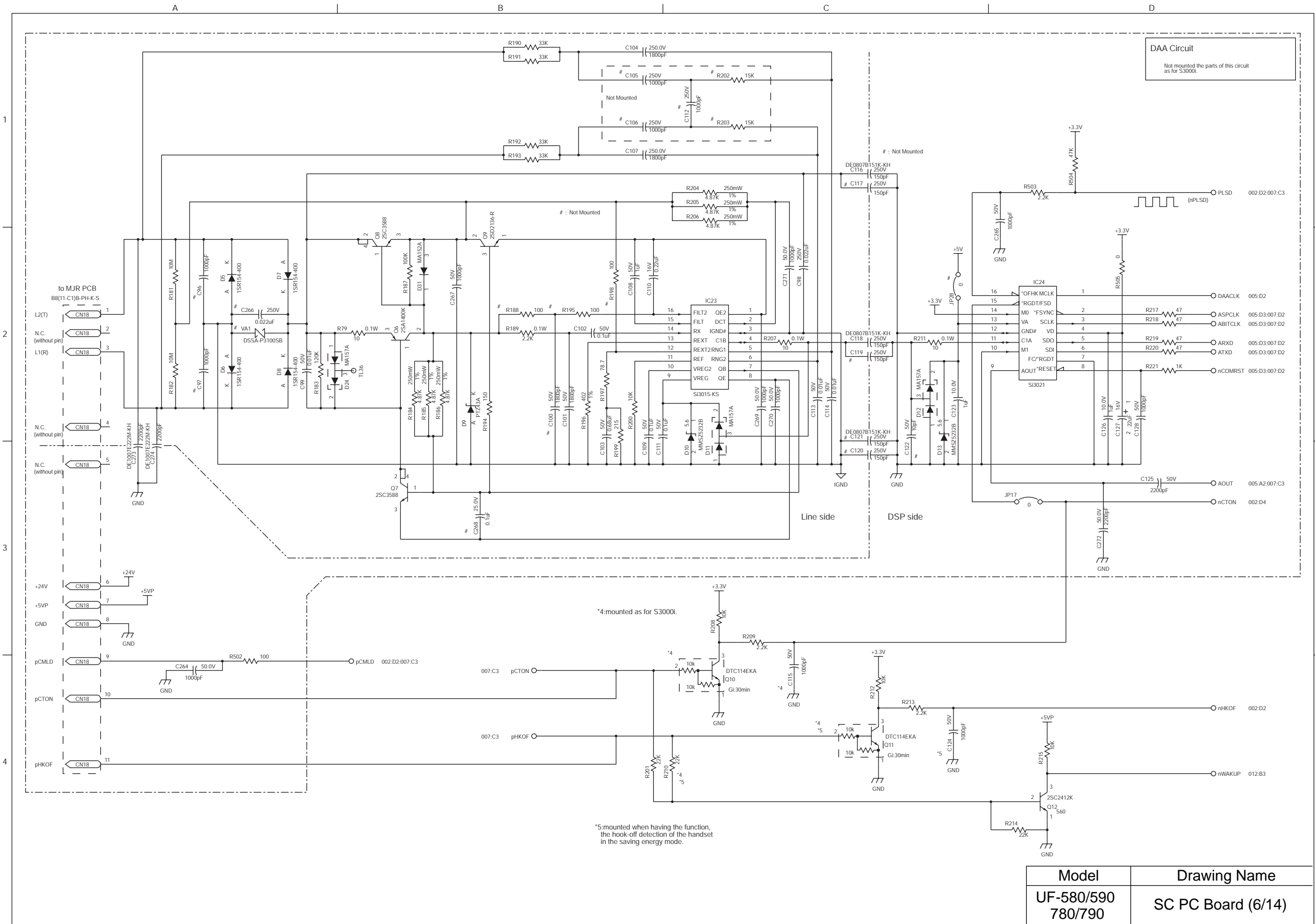

\*4: mounted as for S3000i.

\*5: mounted when having the function, the hook-off detection of the handset in the saving energy mode.

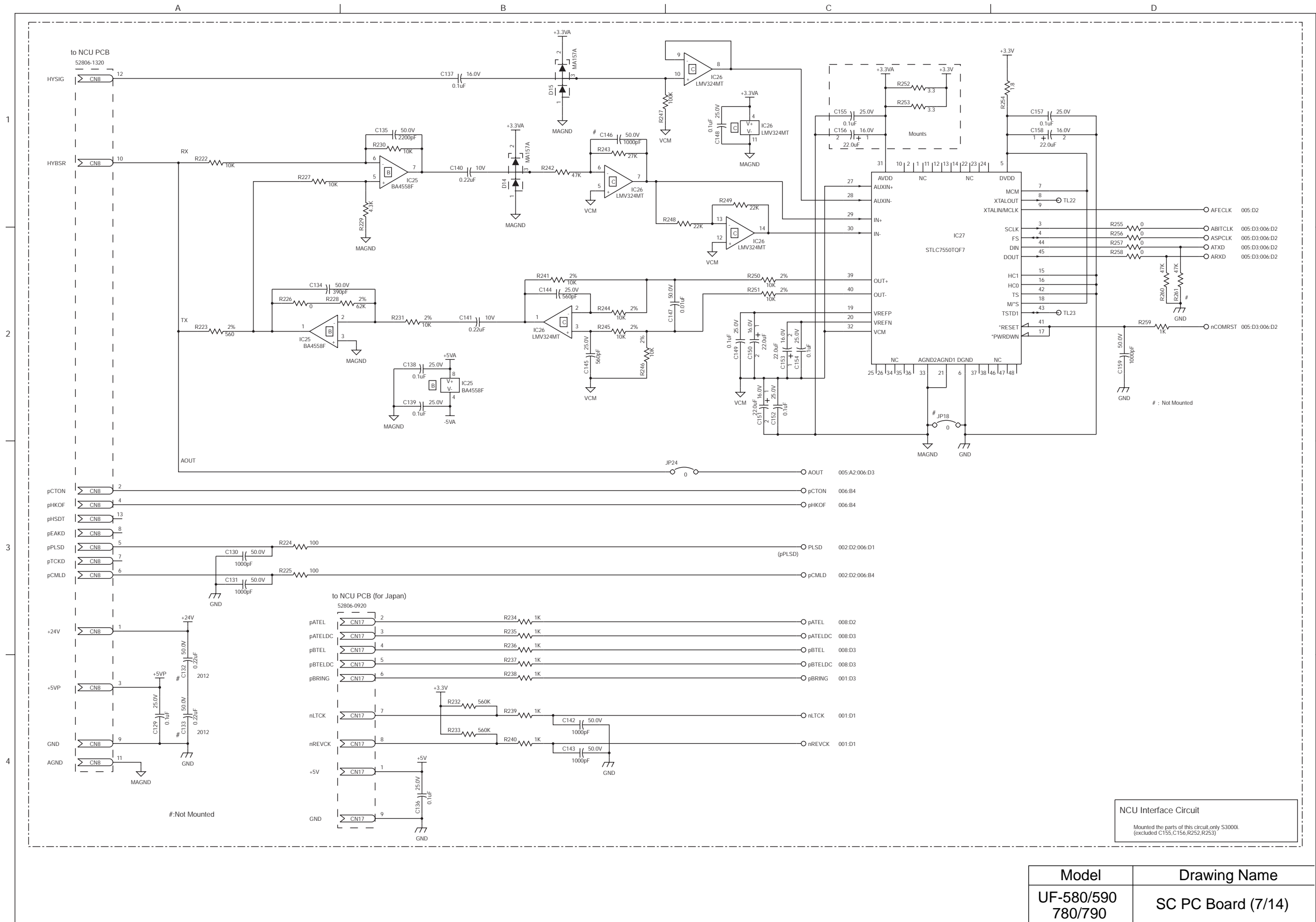



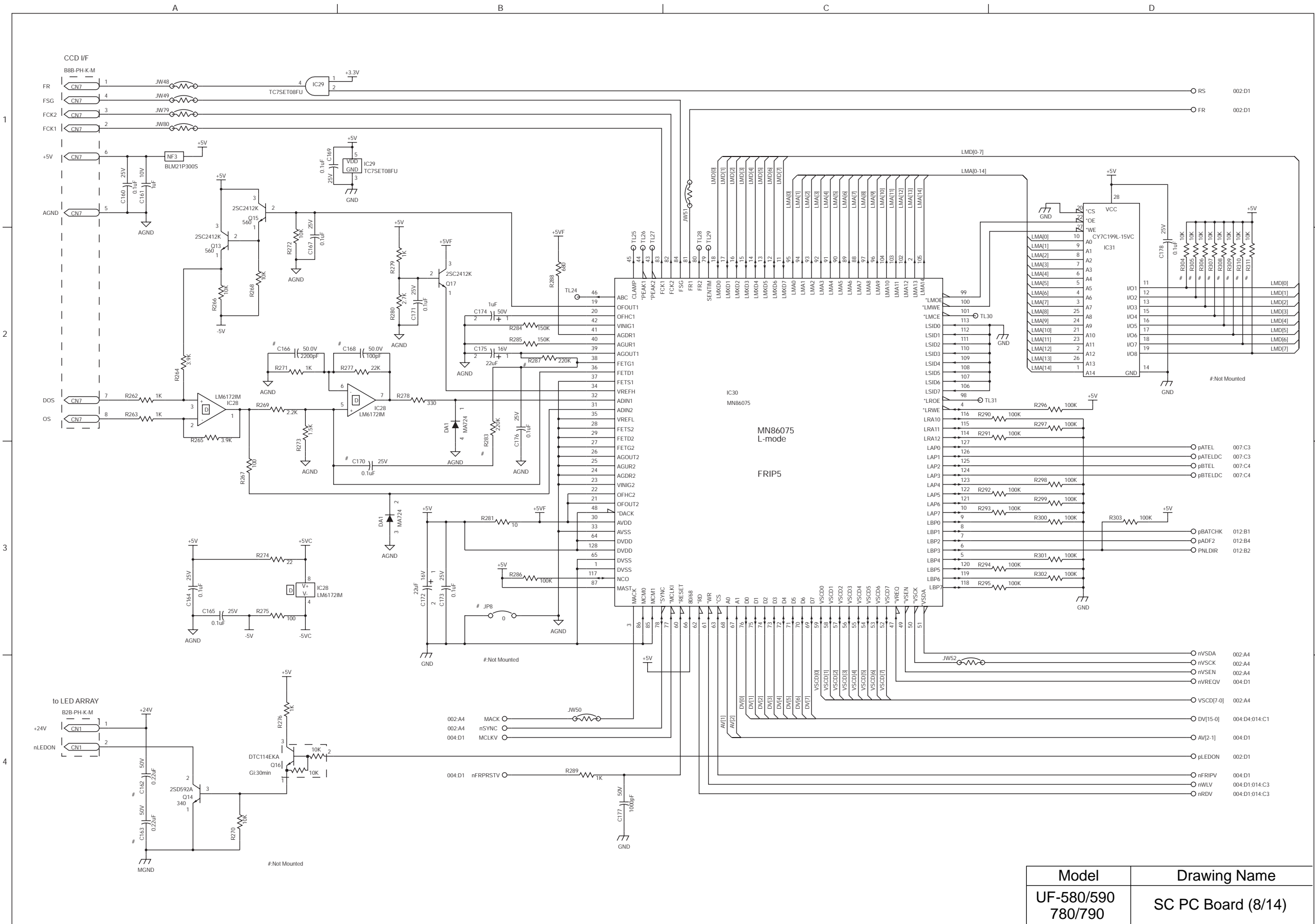

Model	Drawing Name
UF-580/590 780/790	SC PC Board (8/14)





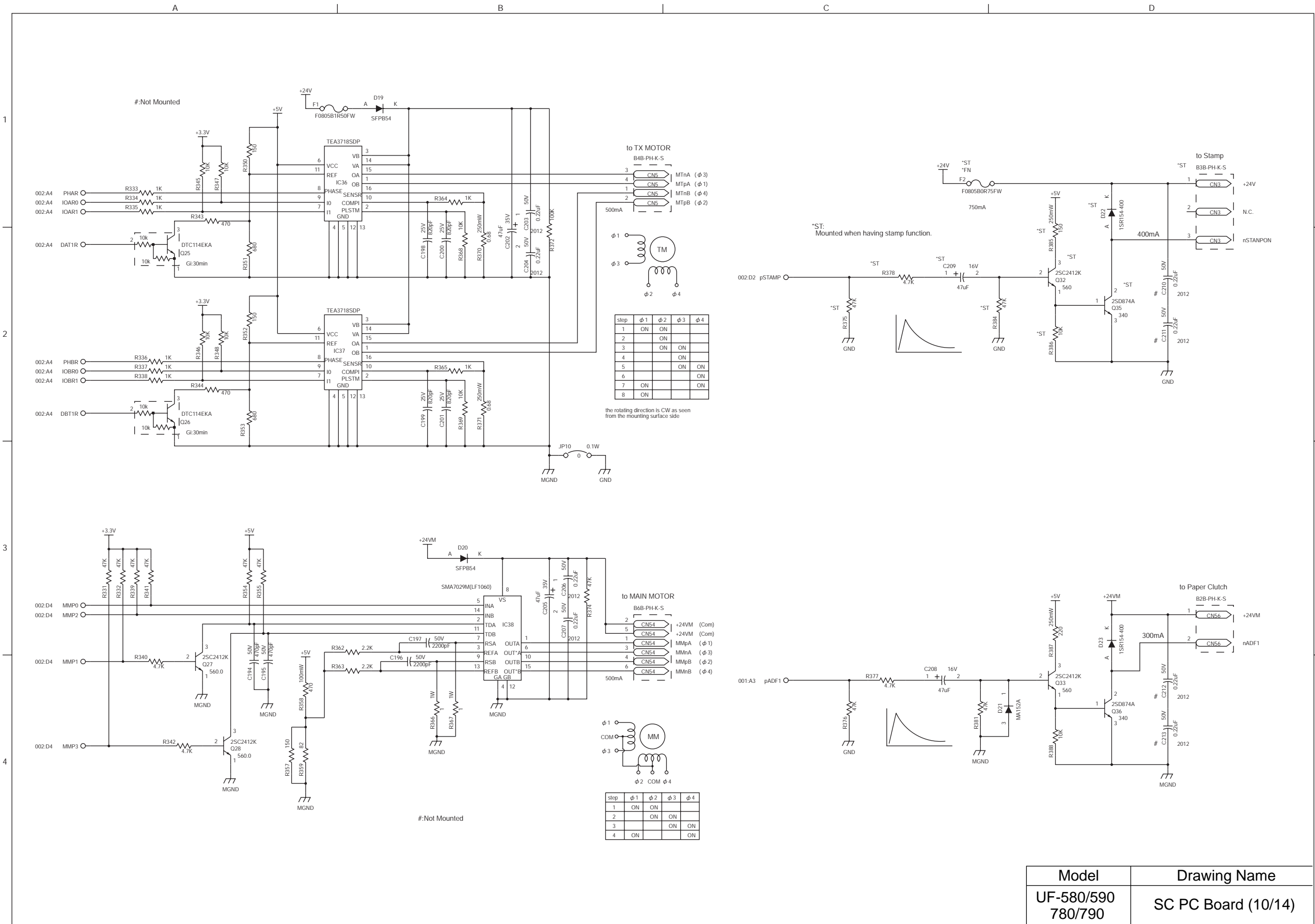

Model	Drawing Name
UF-580/590 780/790	SC PC Board (10/14)

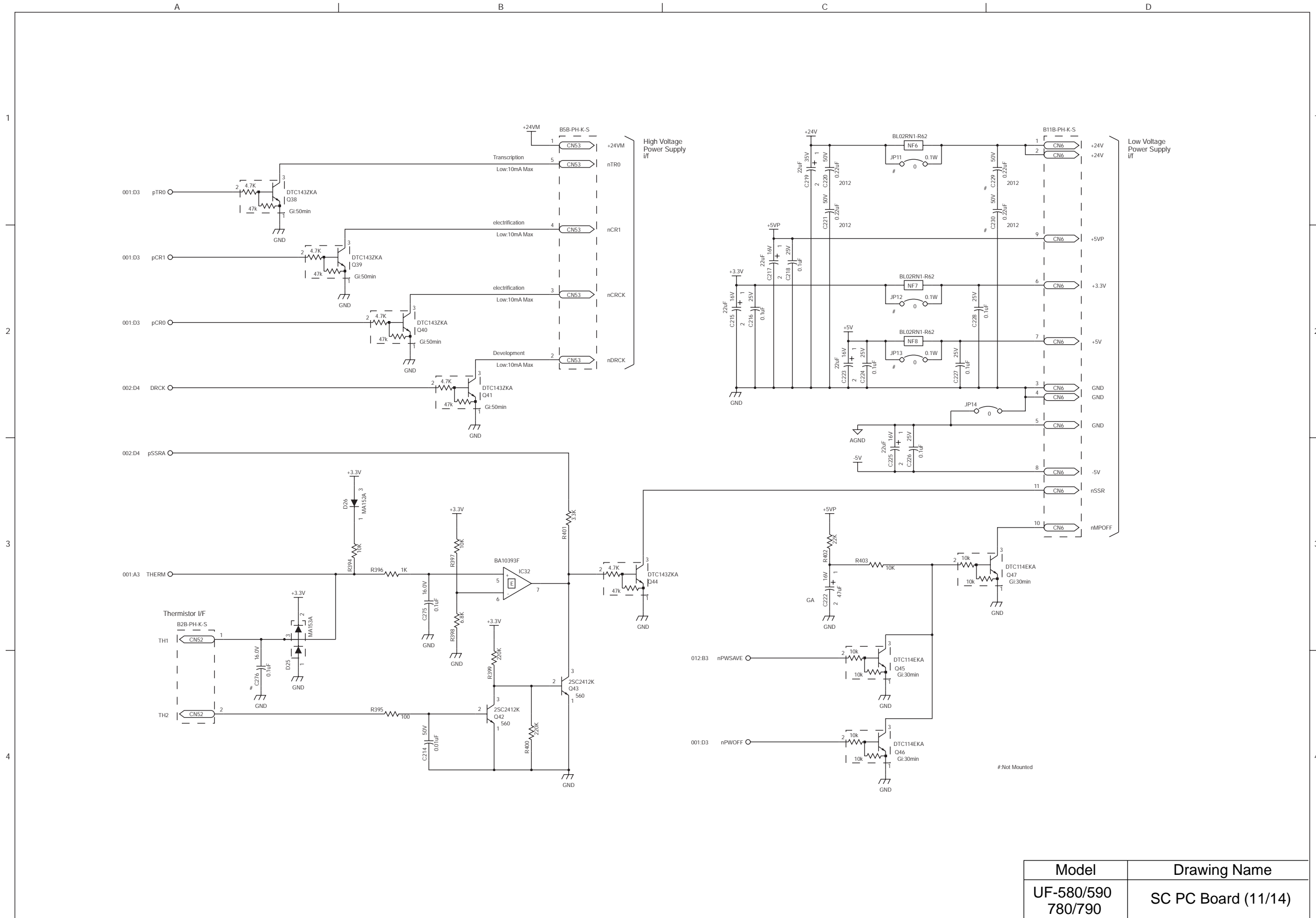

Model	Drawing Name
UF-580/590 780/790	SC PC Board (11/14)

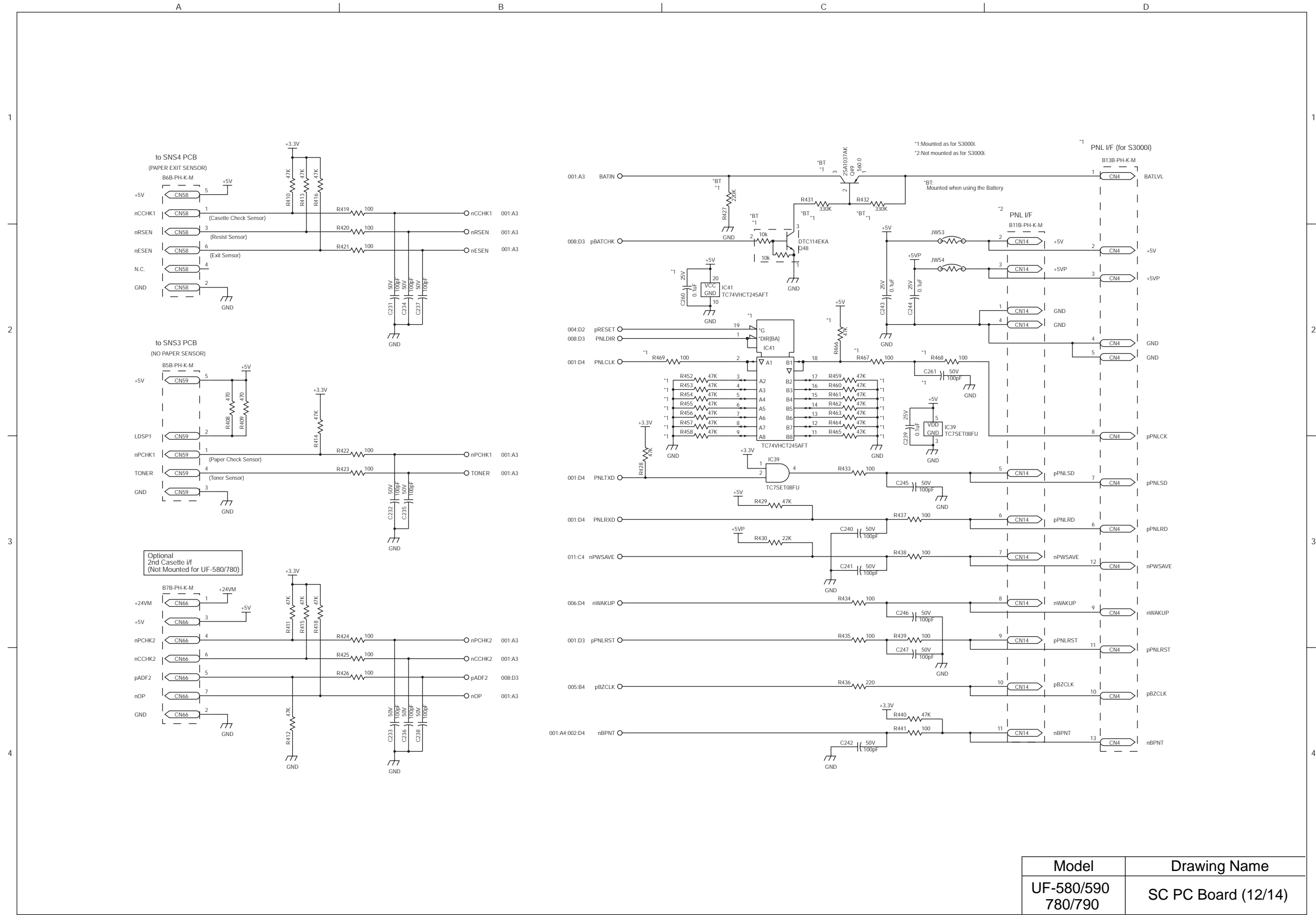

Model	Drawing Name
UF-580/590 780/790	SC PC Board (12/14)

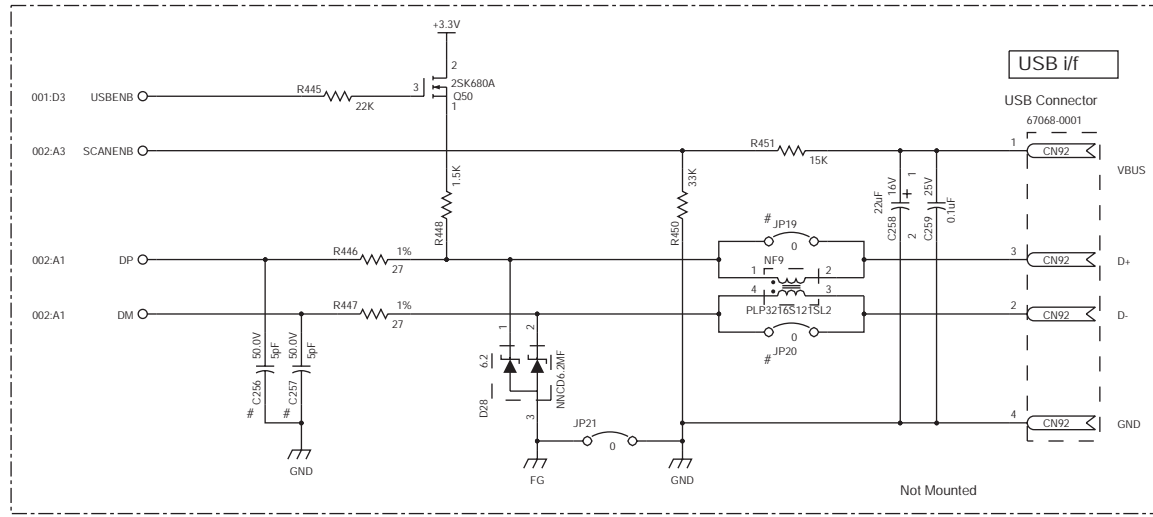
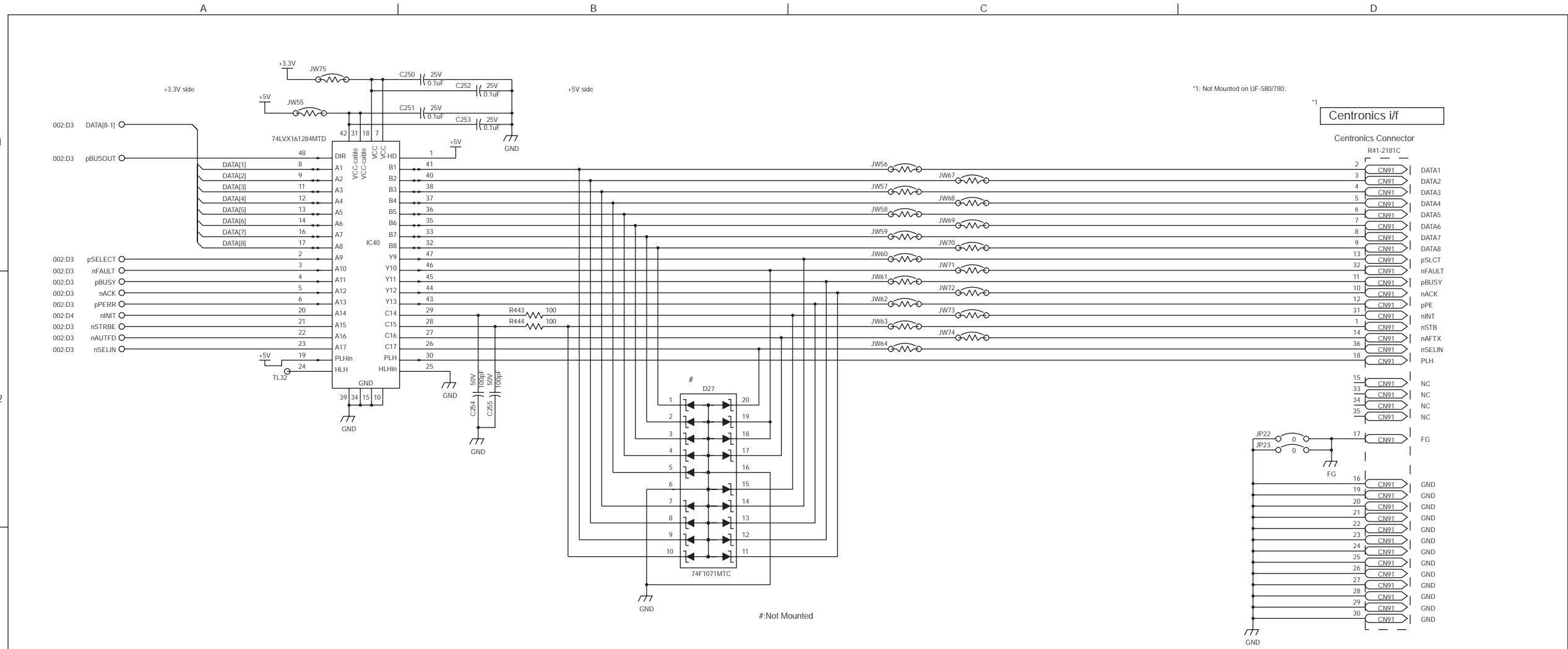

Model	Drawing Name
UF-580/590 780/790	SC PC Board (13/14)

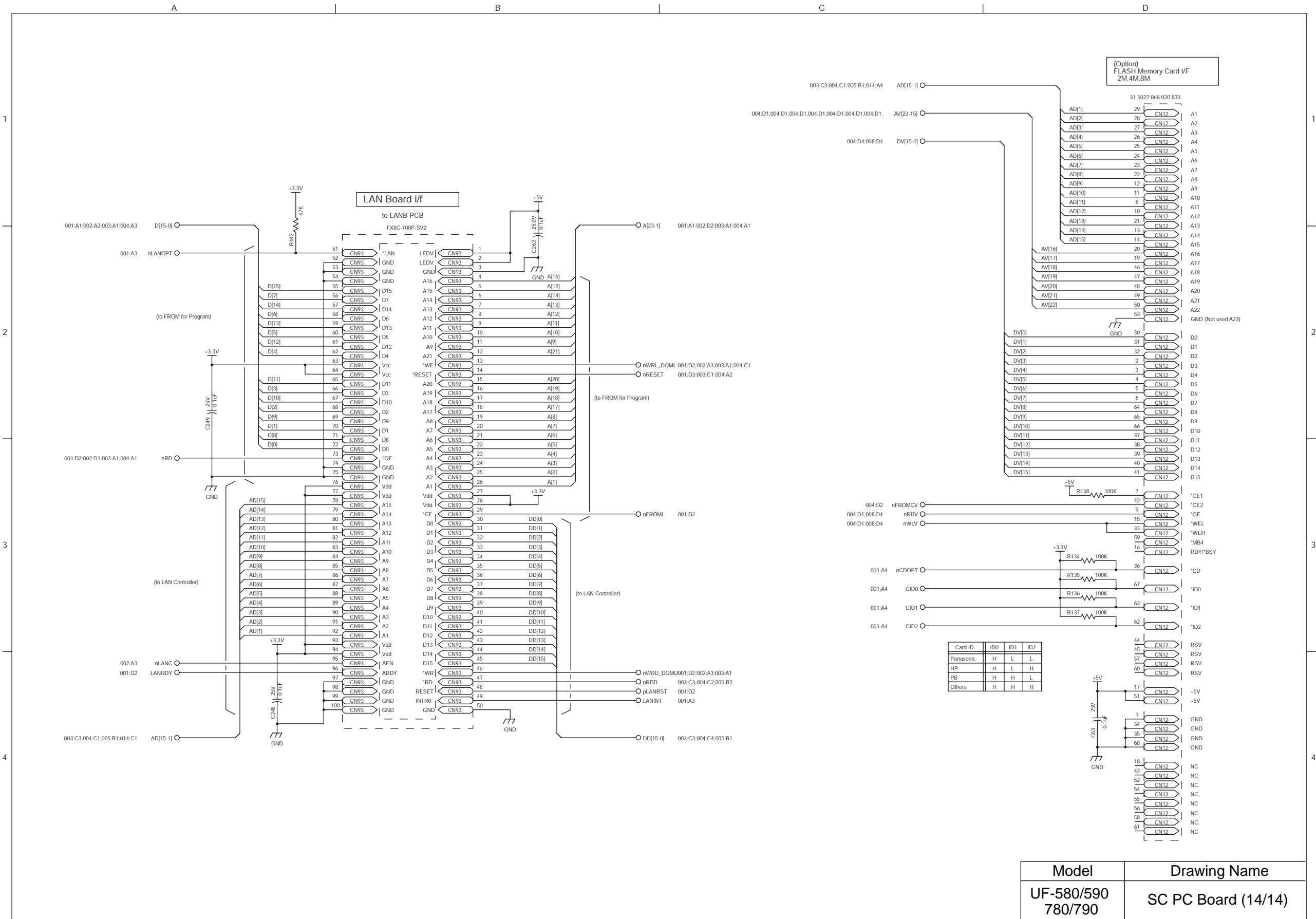

# 10.3. SC PC Board (For UF-5100/6000/6100)

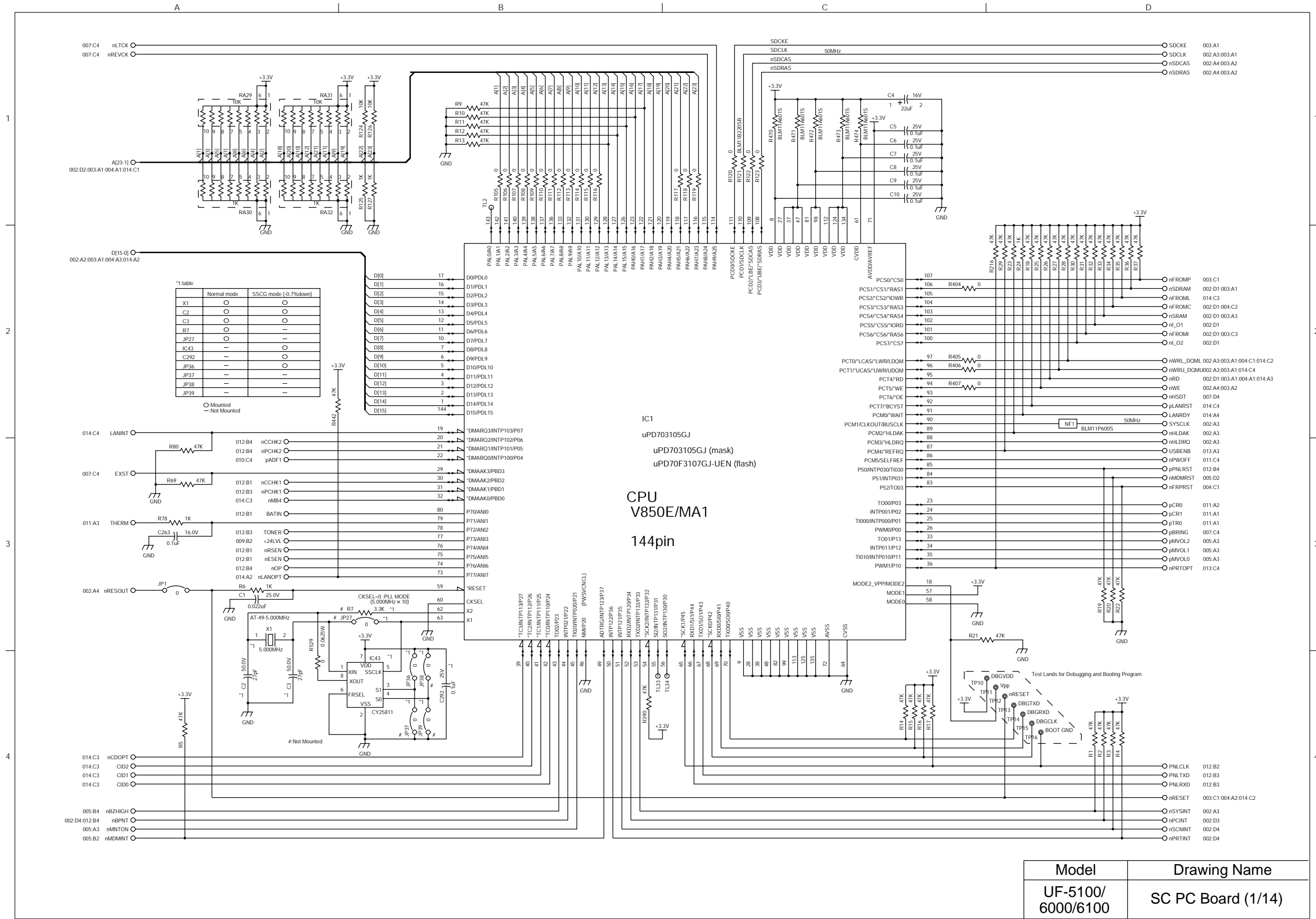

Model	Drawing Name
UF-5100/ 6000/6100	SC PC Board (1/14)

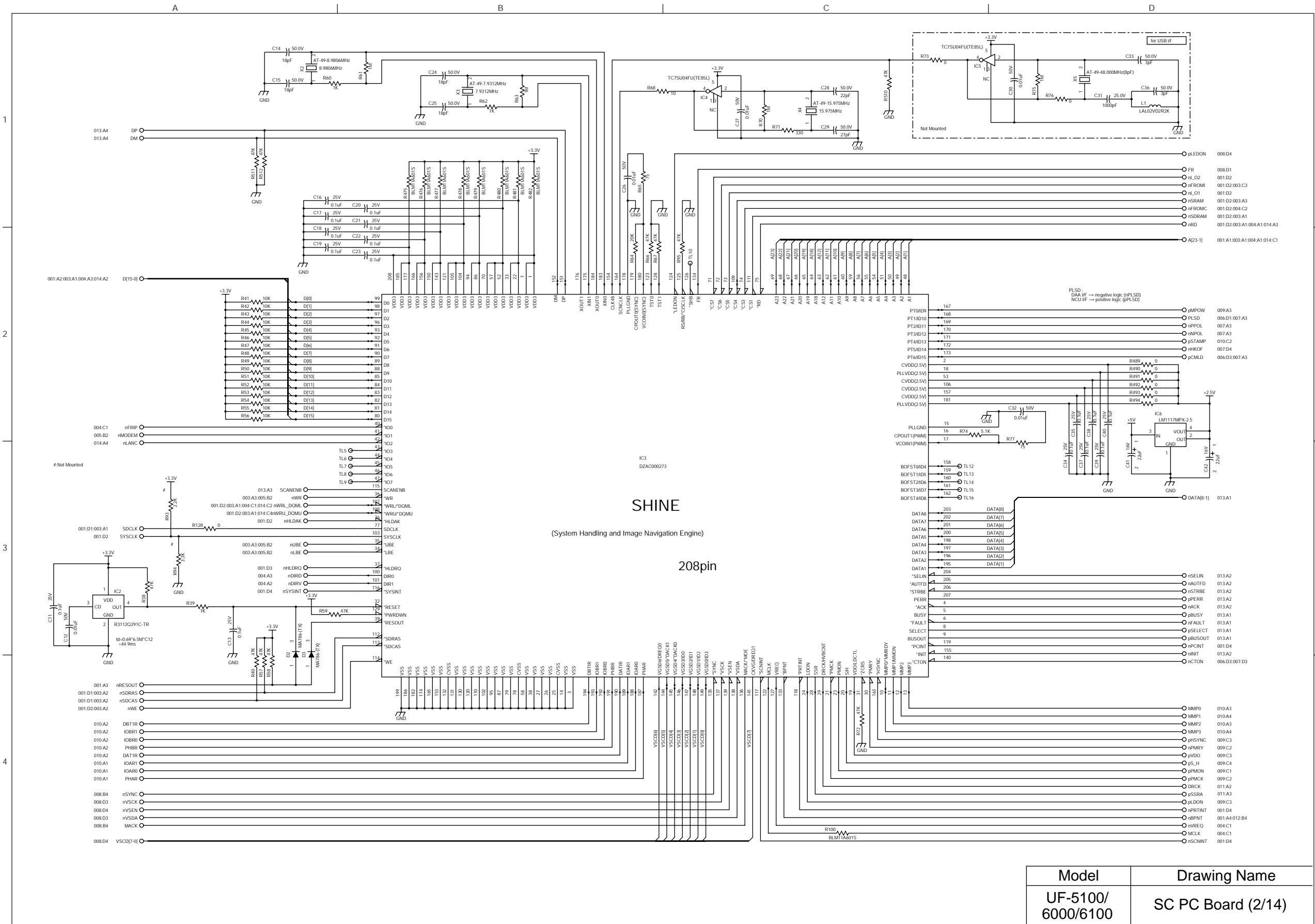



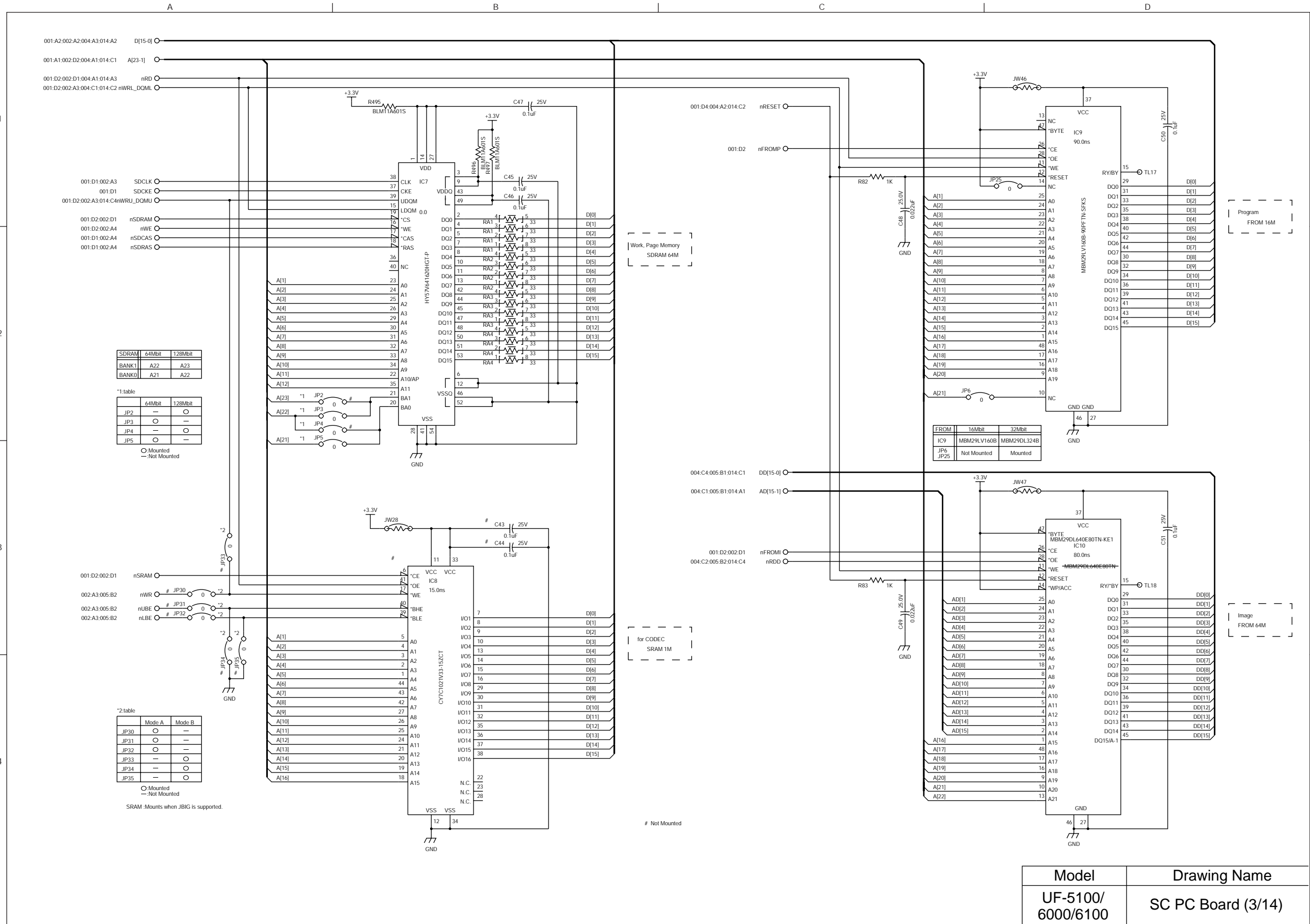

Model	Drawing Name
UF-5100/ 6000/6100	SC PC Board (3/14)

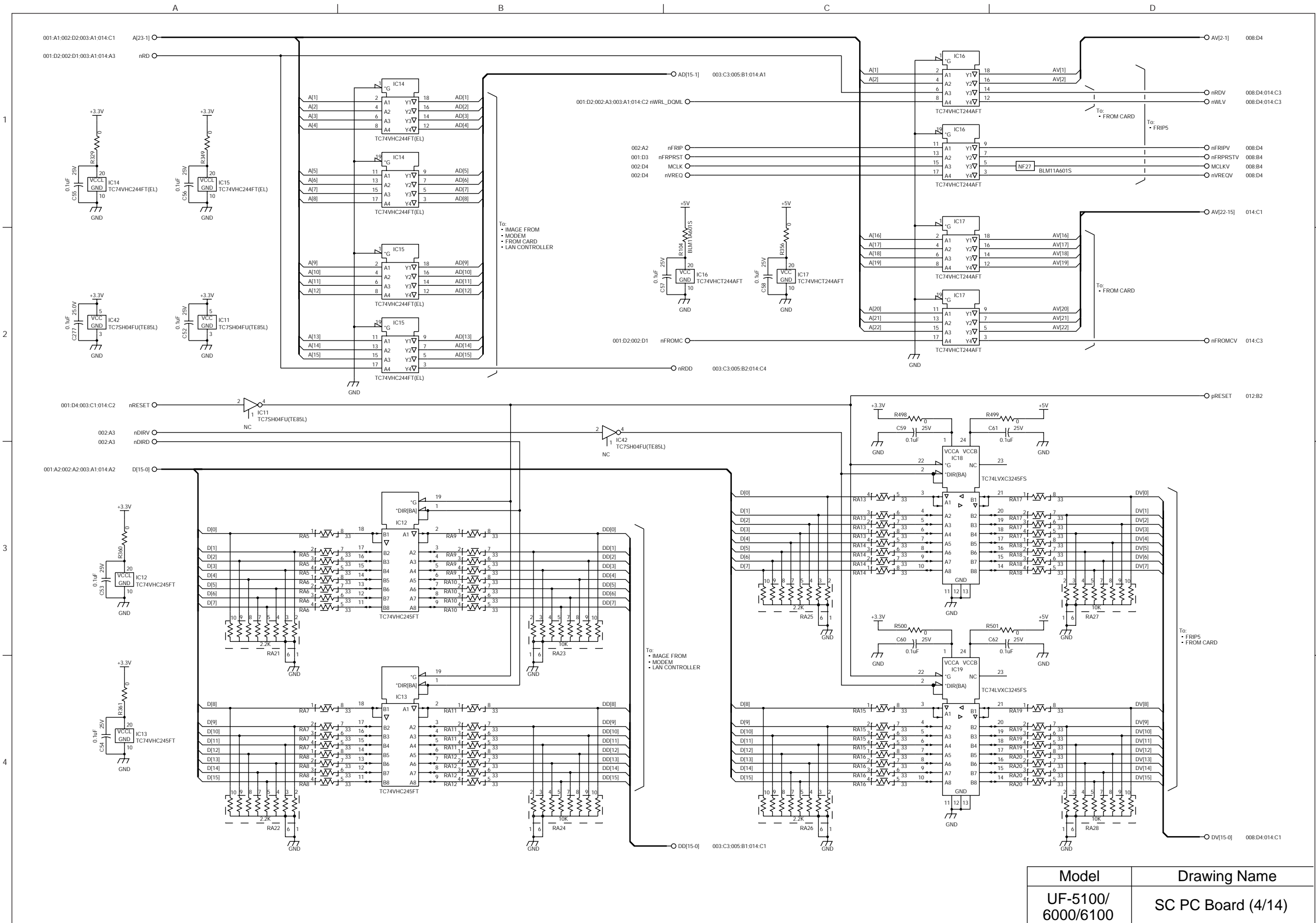

Model	Drawing Name
UF-5100/ 6000/6100	SC PC Board (4/14)

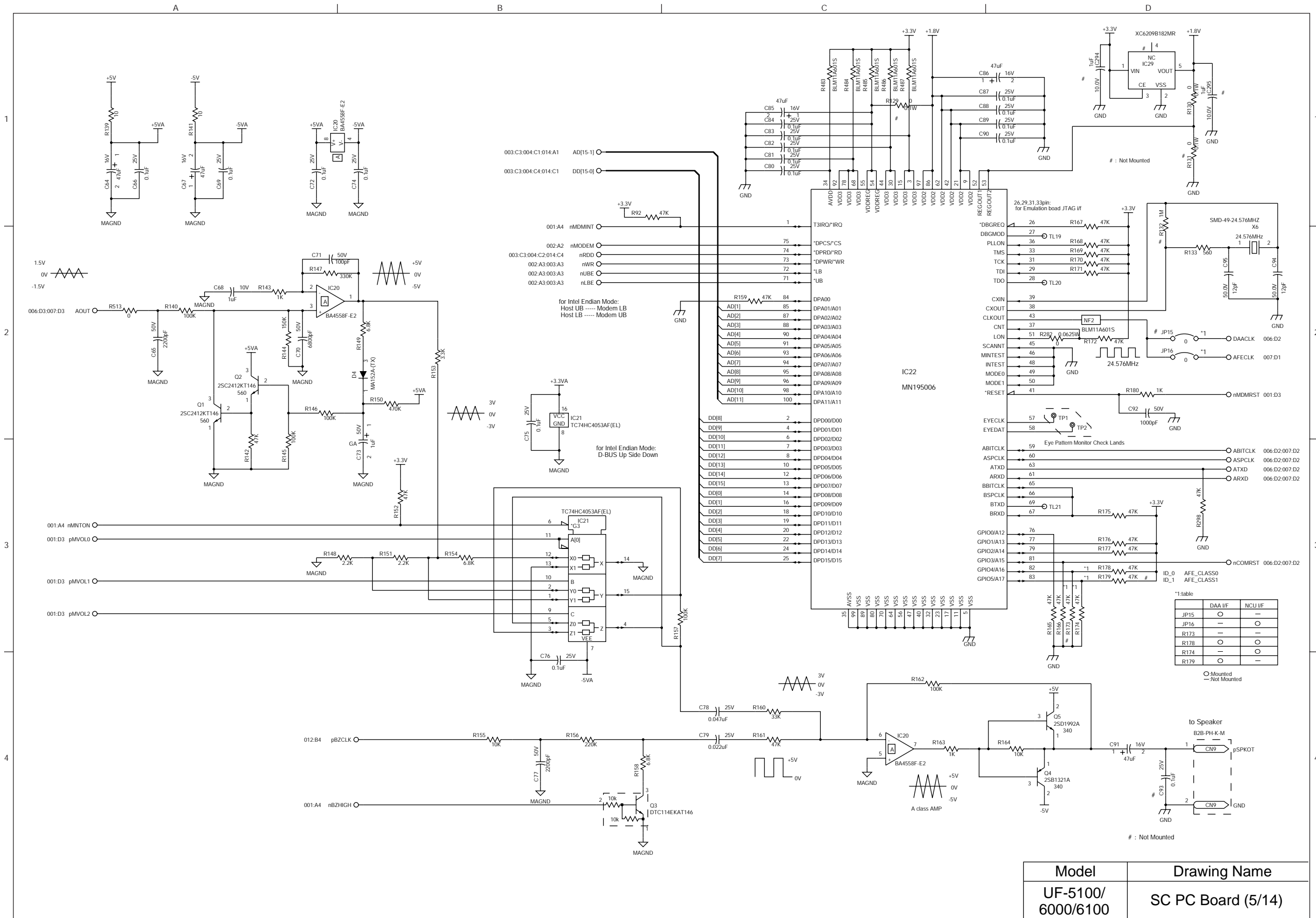

Model	Drawing Name
UF-5100/ 6000/6100	SC PC Board (5/14)



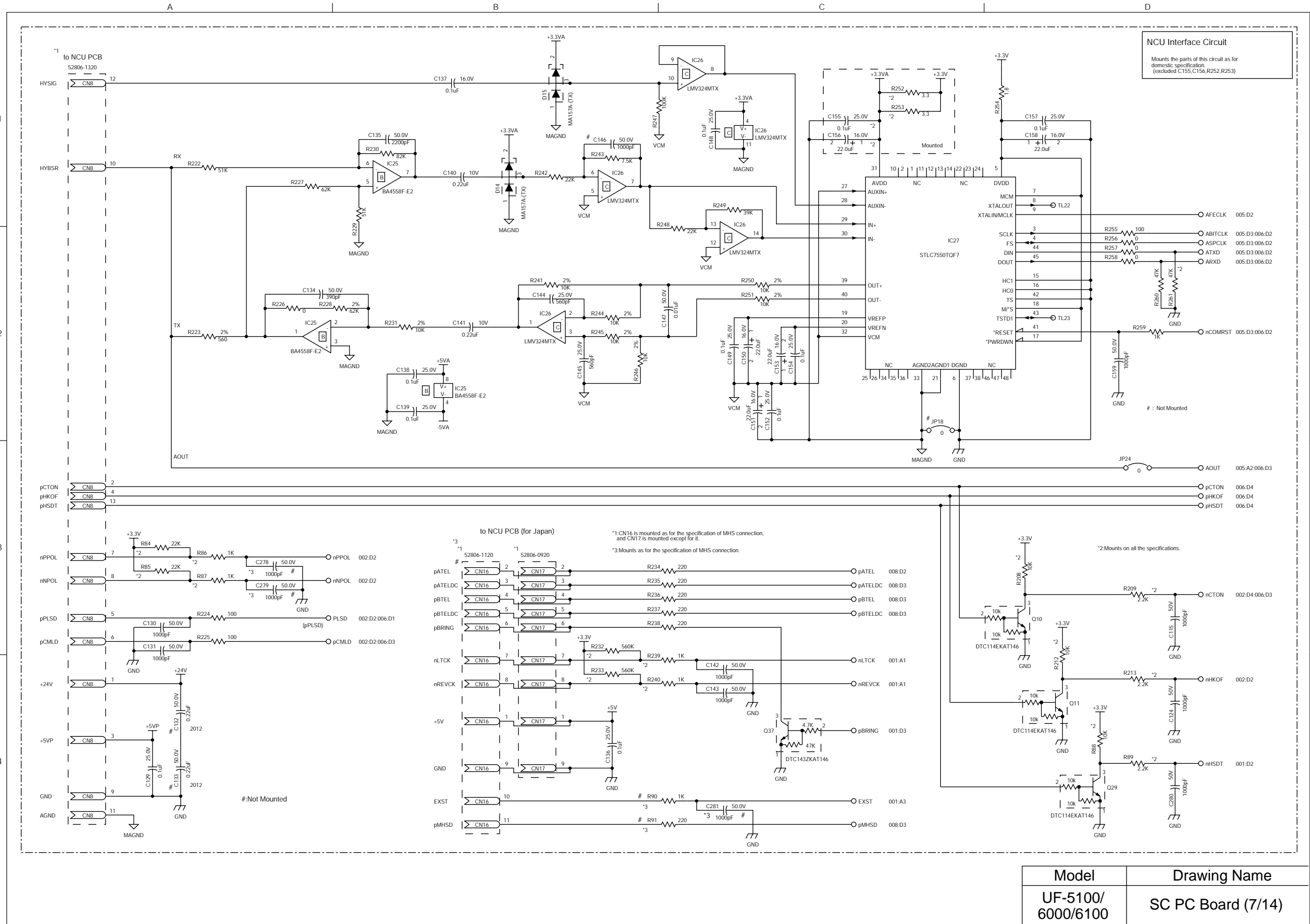

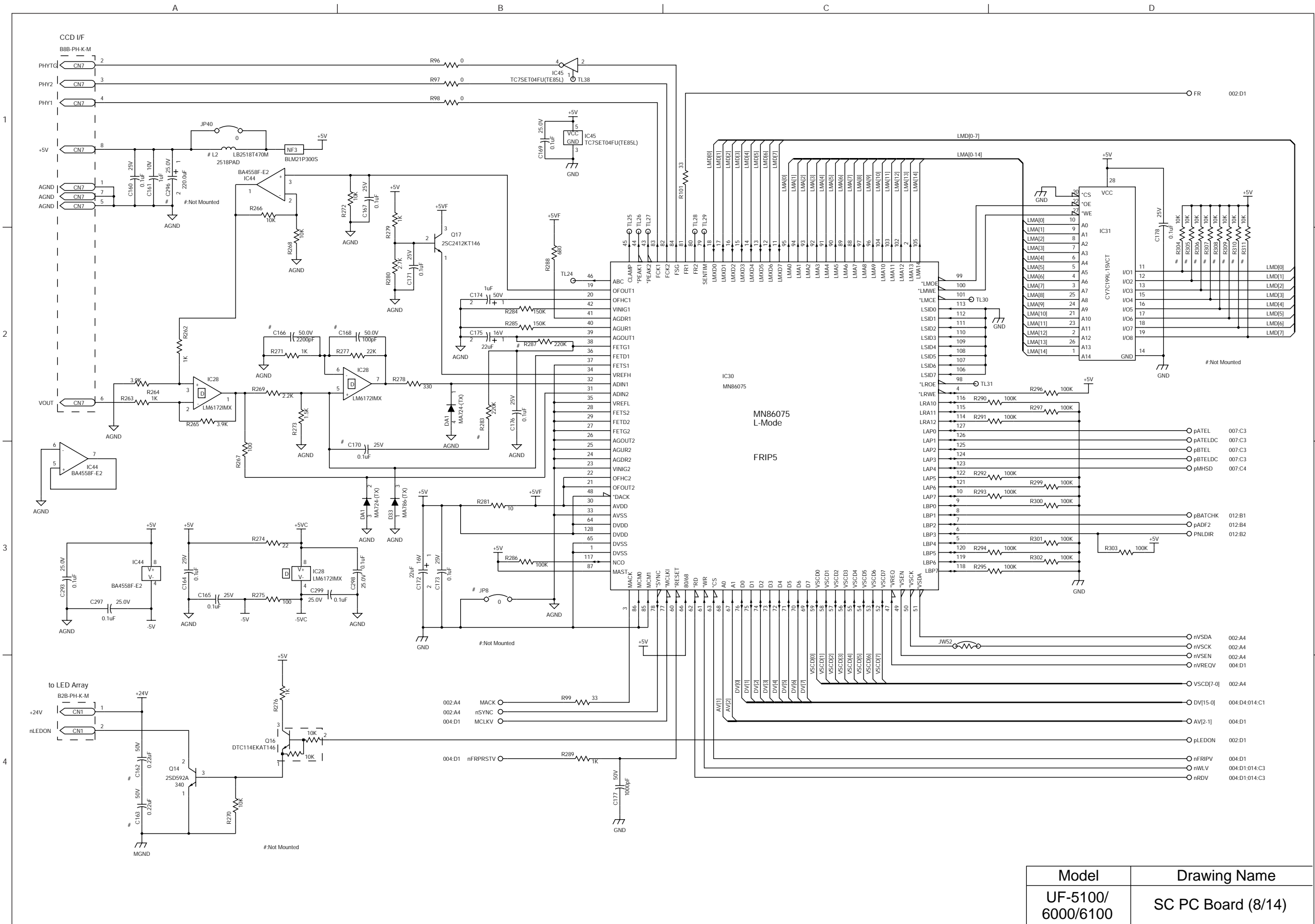

Model	Drawing Name
UF-5100/ 6000/6100	SC PC Board (8/14)

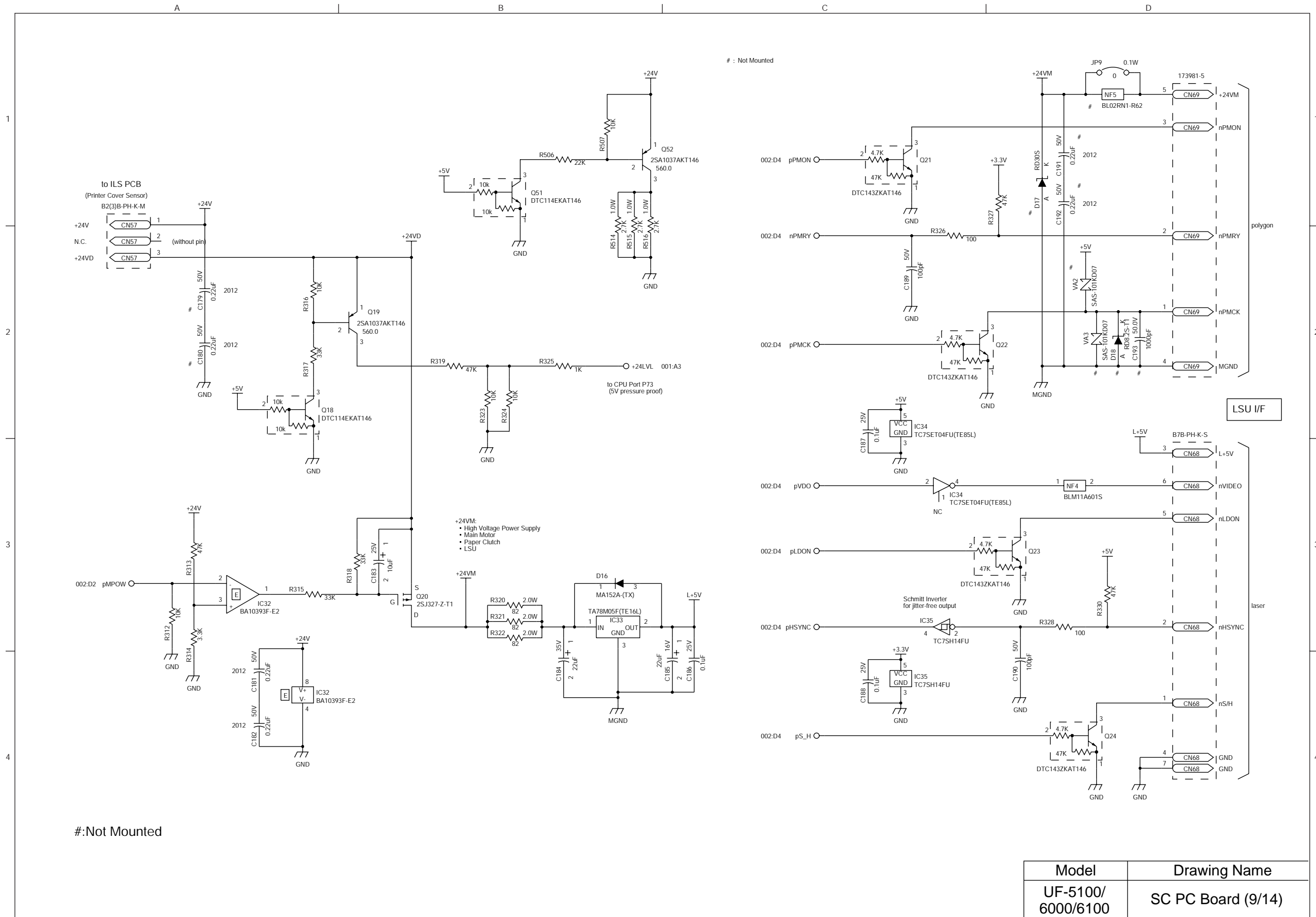

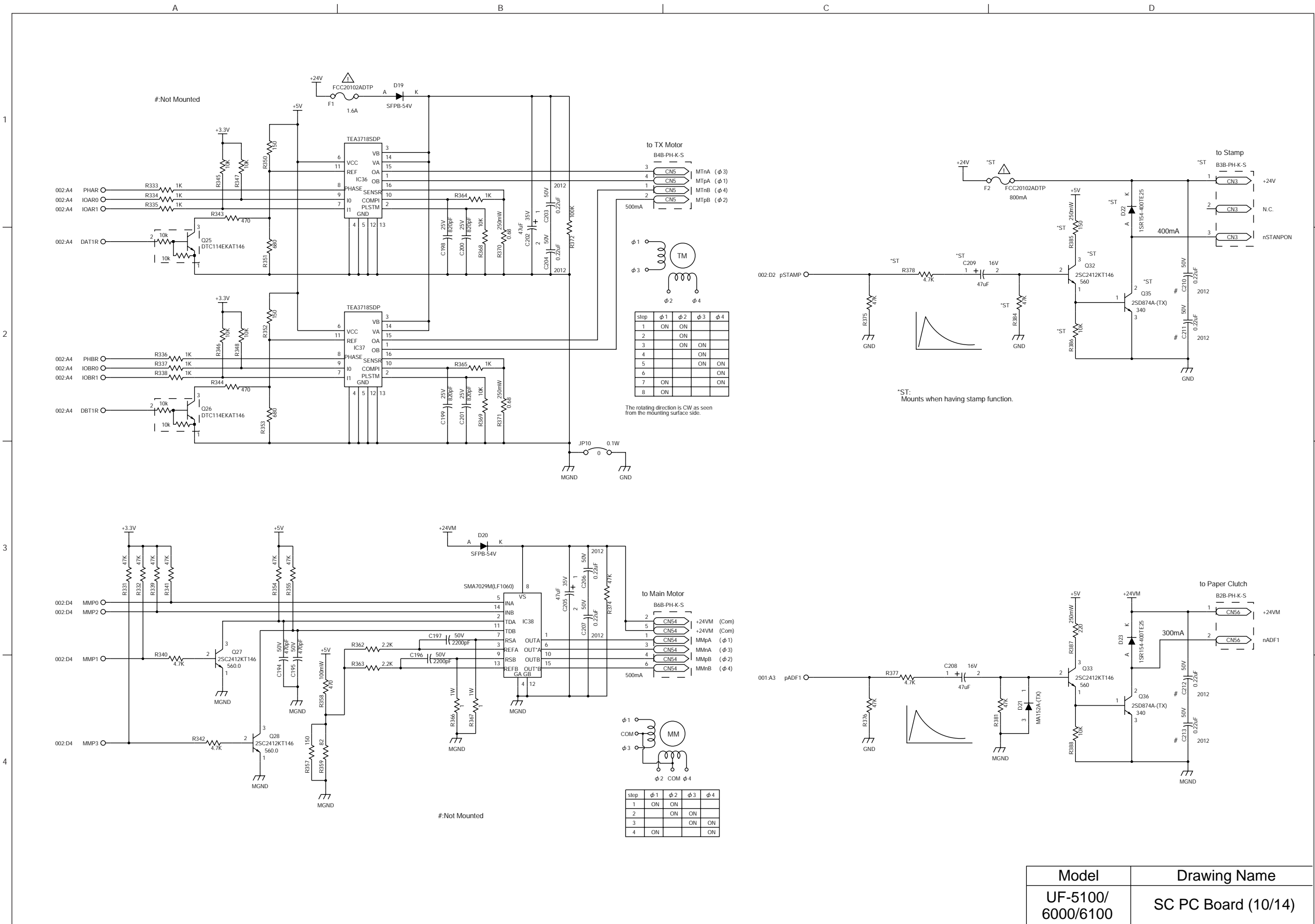



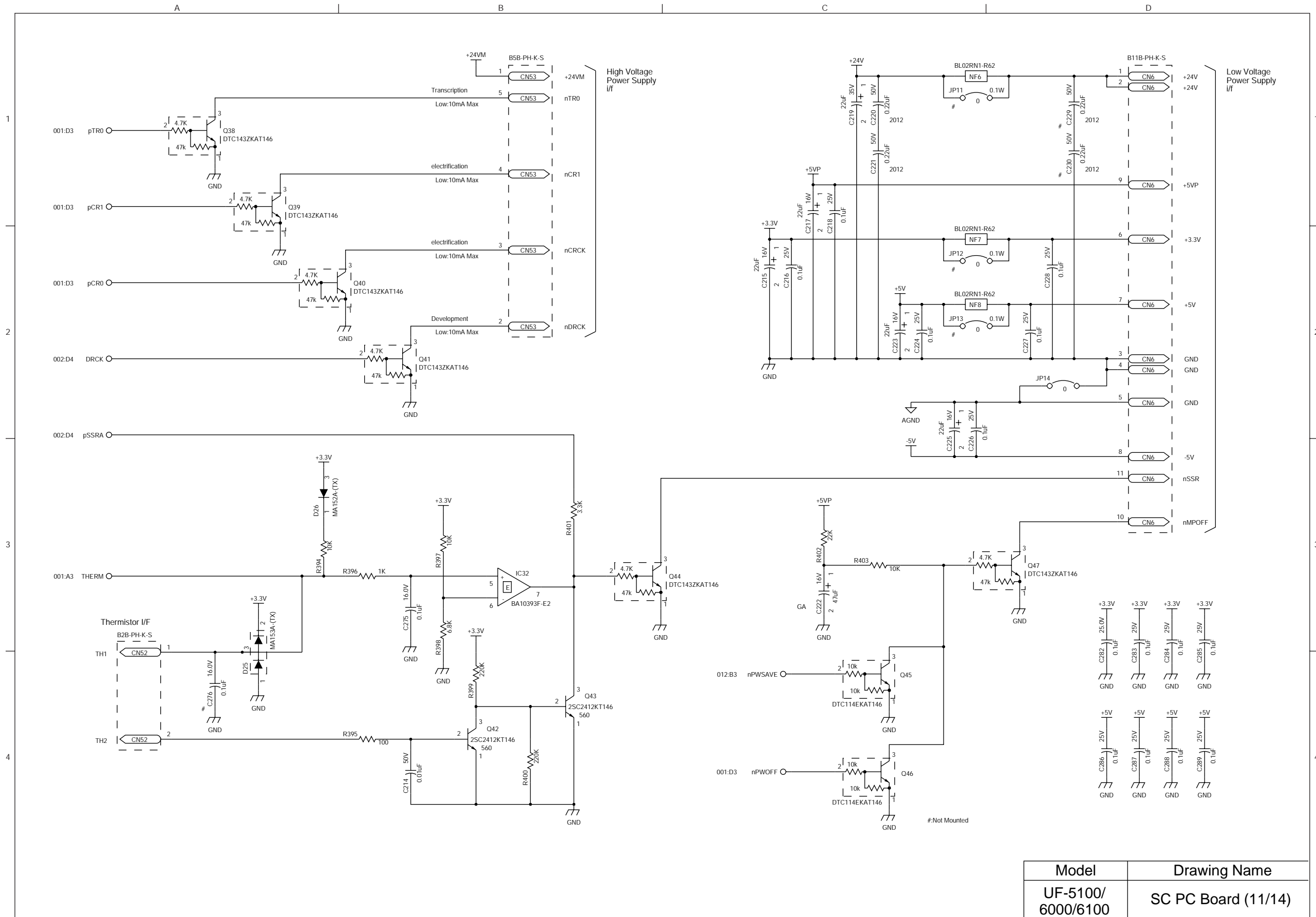

Model	Drawing Name
UF-5100/ 6000/6100	SC PC Board (11/14)

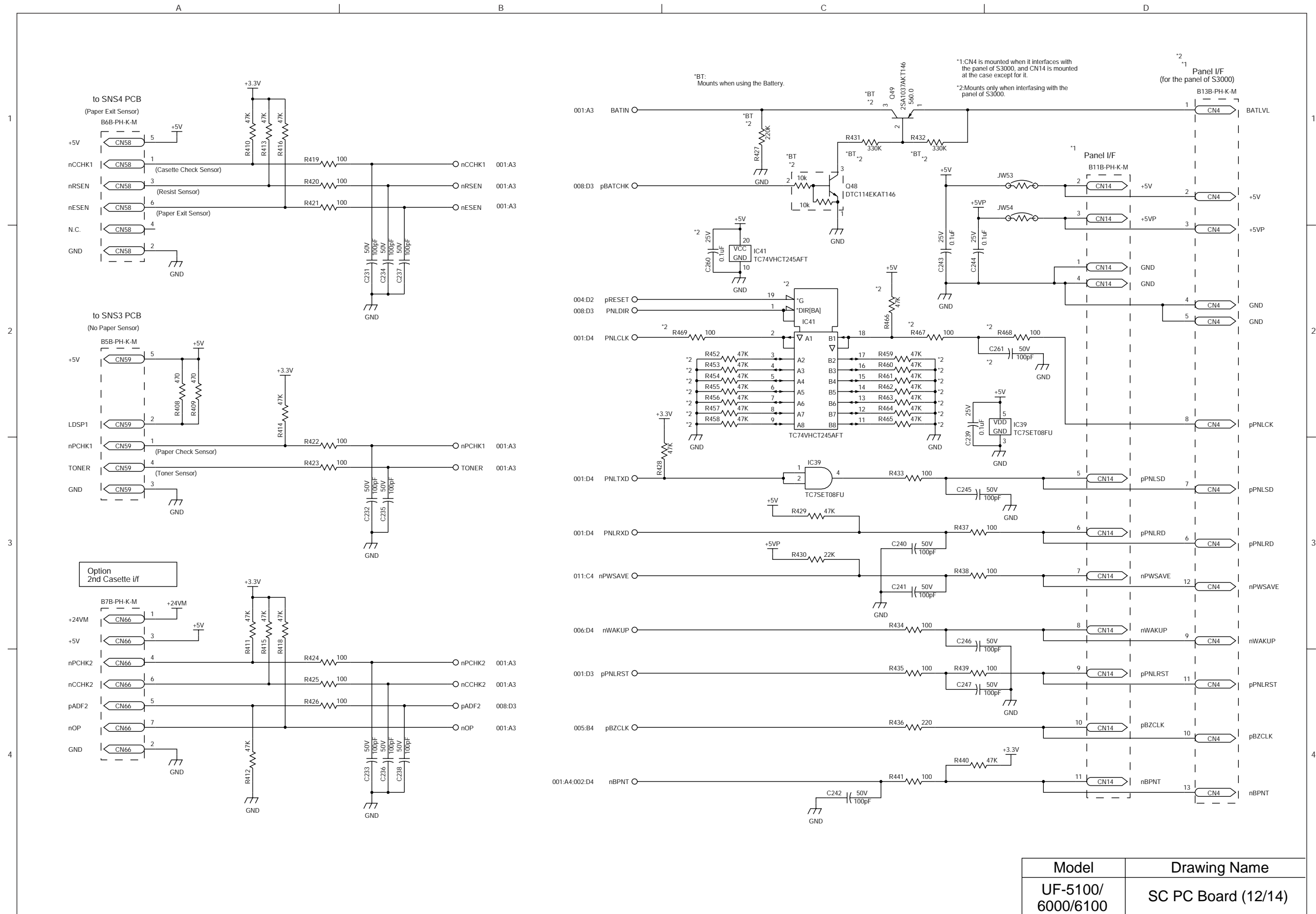

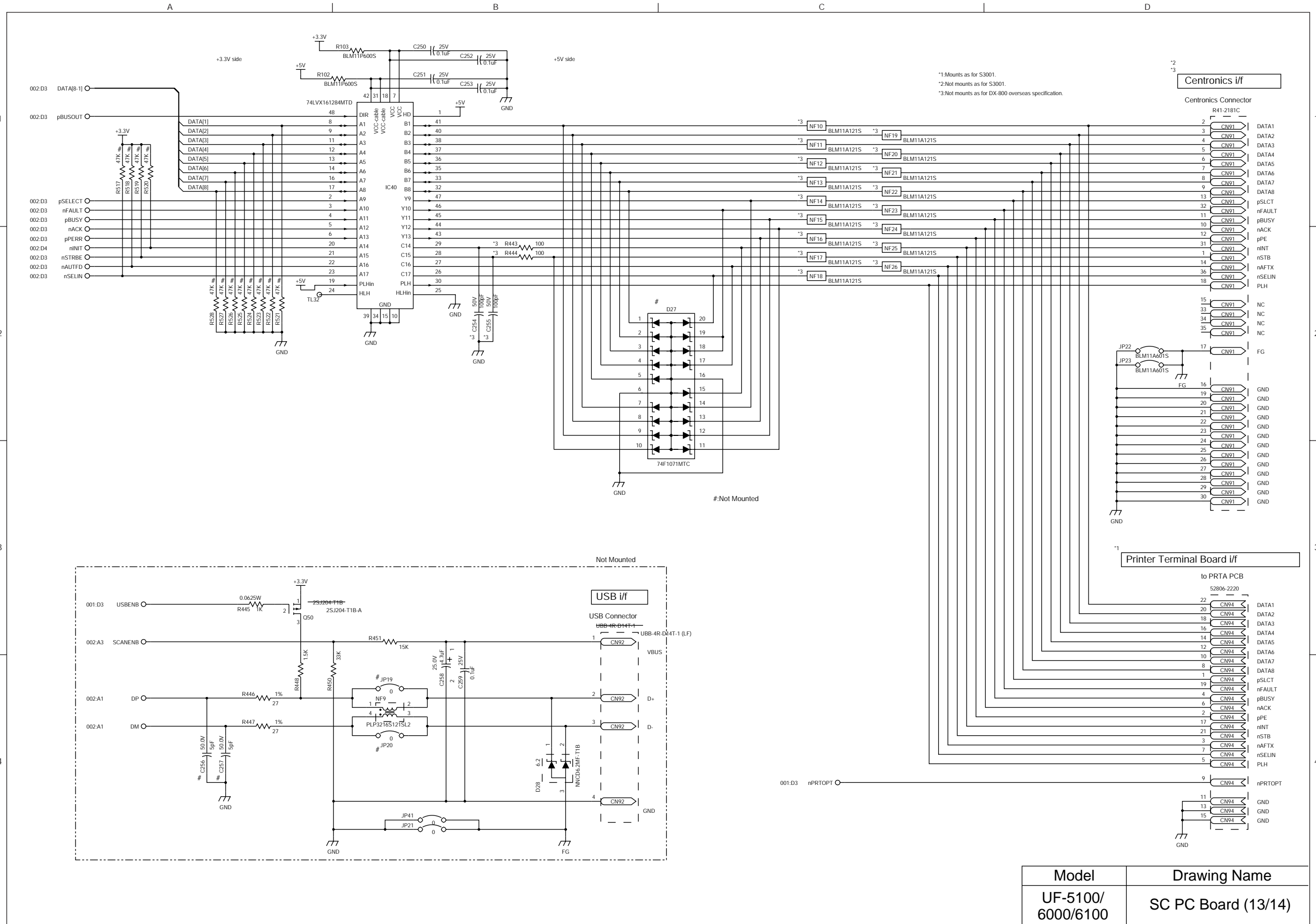

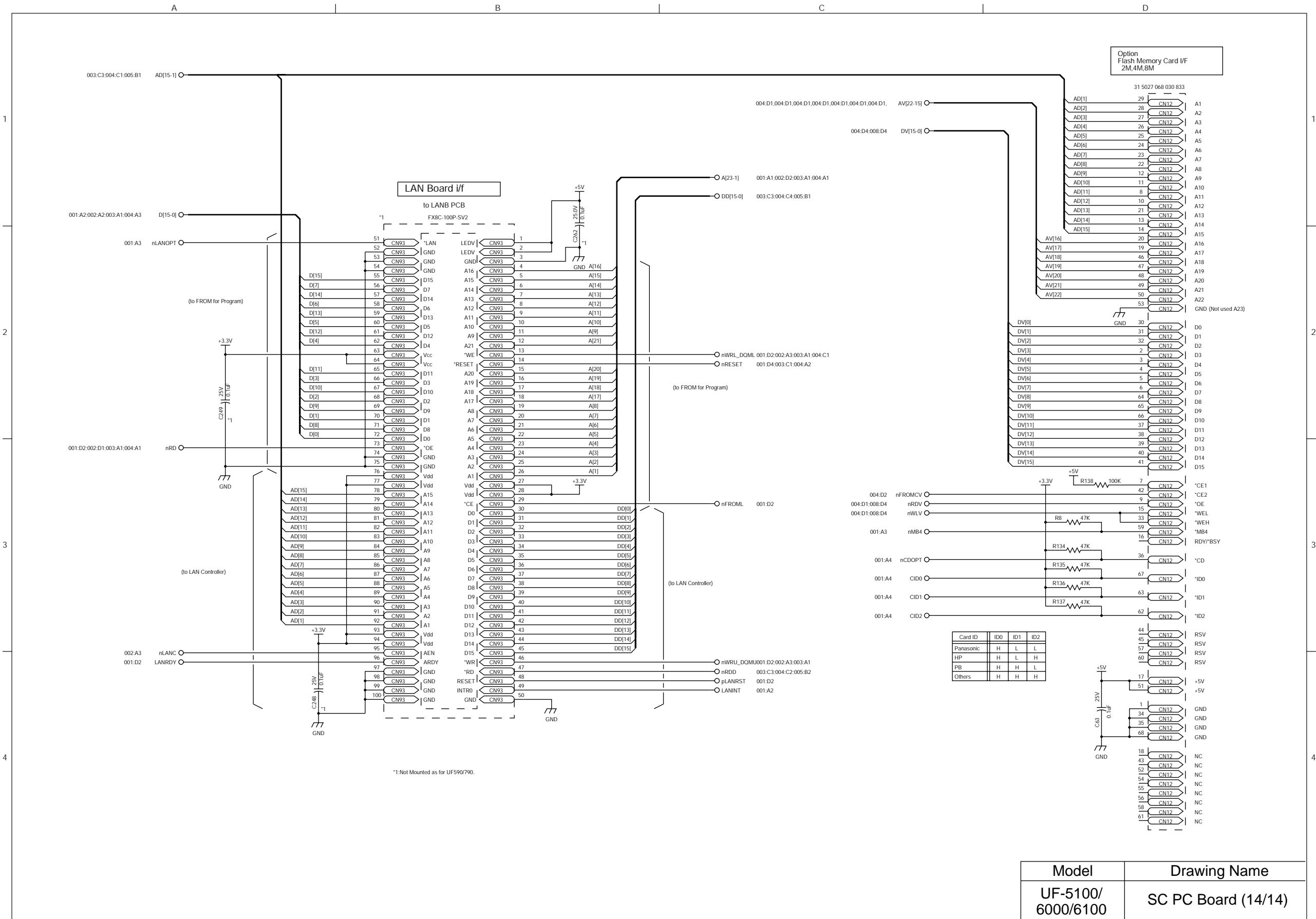

# 10.4. PNL1 PC Board

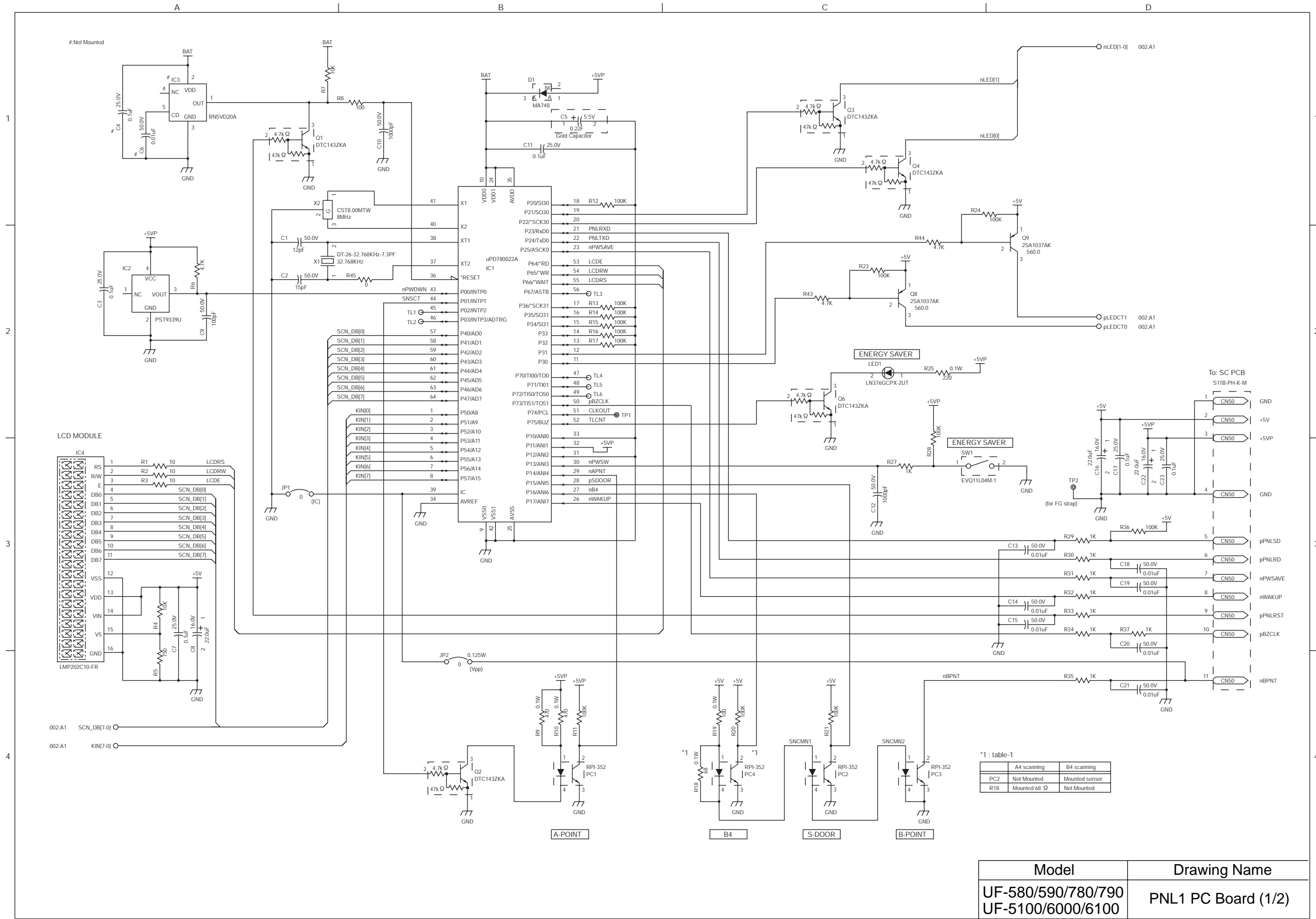

\*1 : table-1

	A4 scanning	B4 scanning
PC2	Not Mounted	Mounted sensor
R18	Mounted 68 $\Omega$	Not Mounted

Model	Drawing Name
UF-580/590/780/790	PNL1 PC Board (1/2)
UF-5100/6000/6100	



# 10.5. MJR PC Board

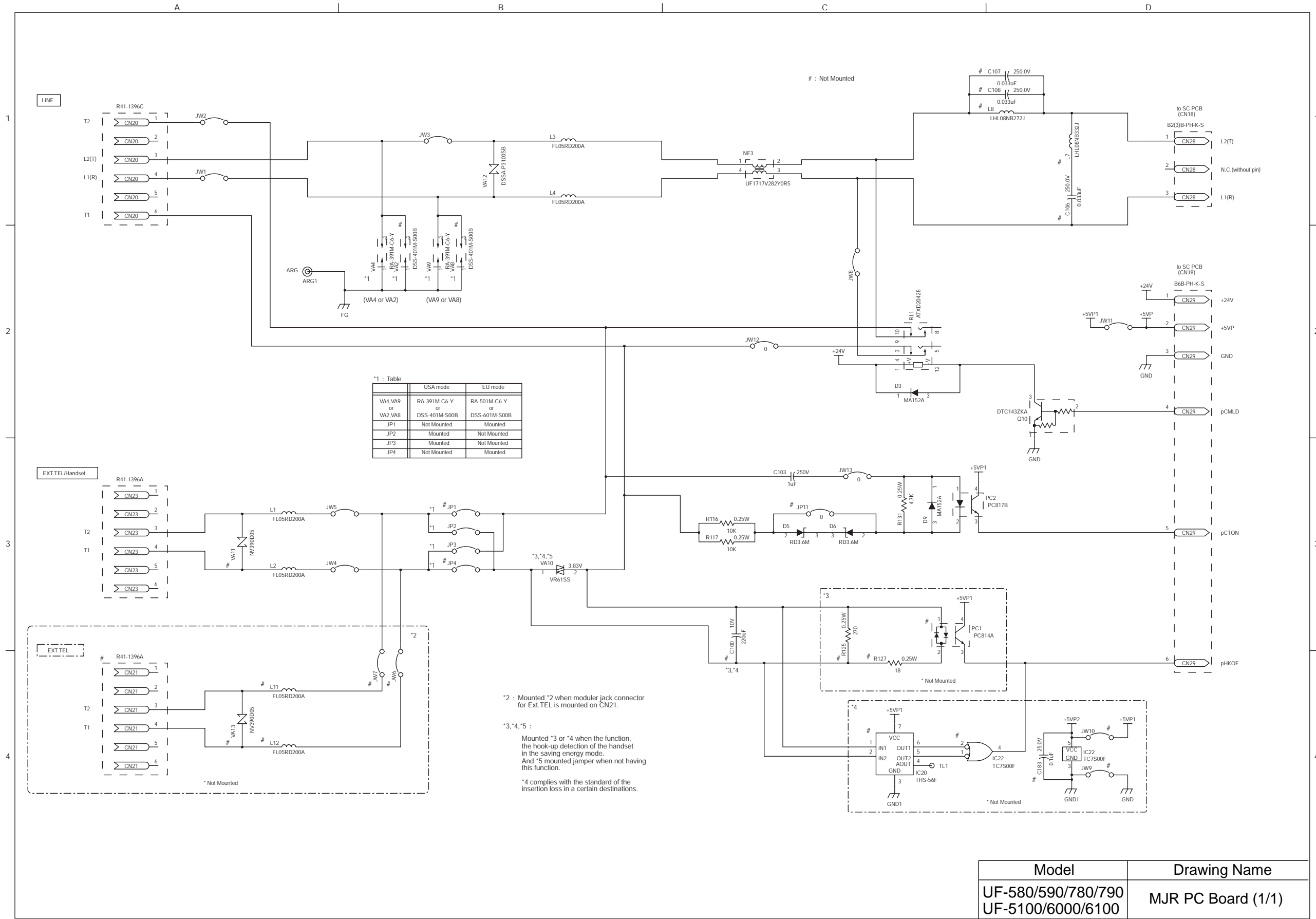

10.6. SNS1 PC Board

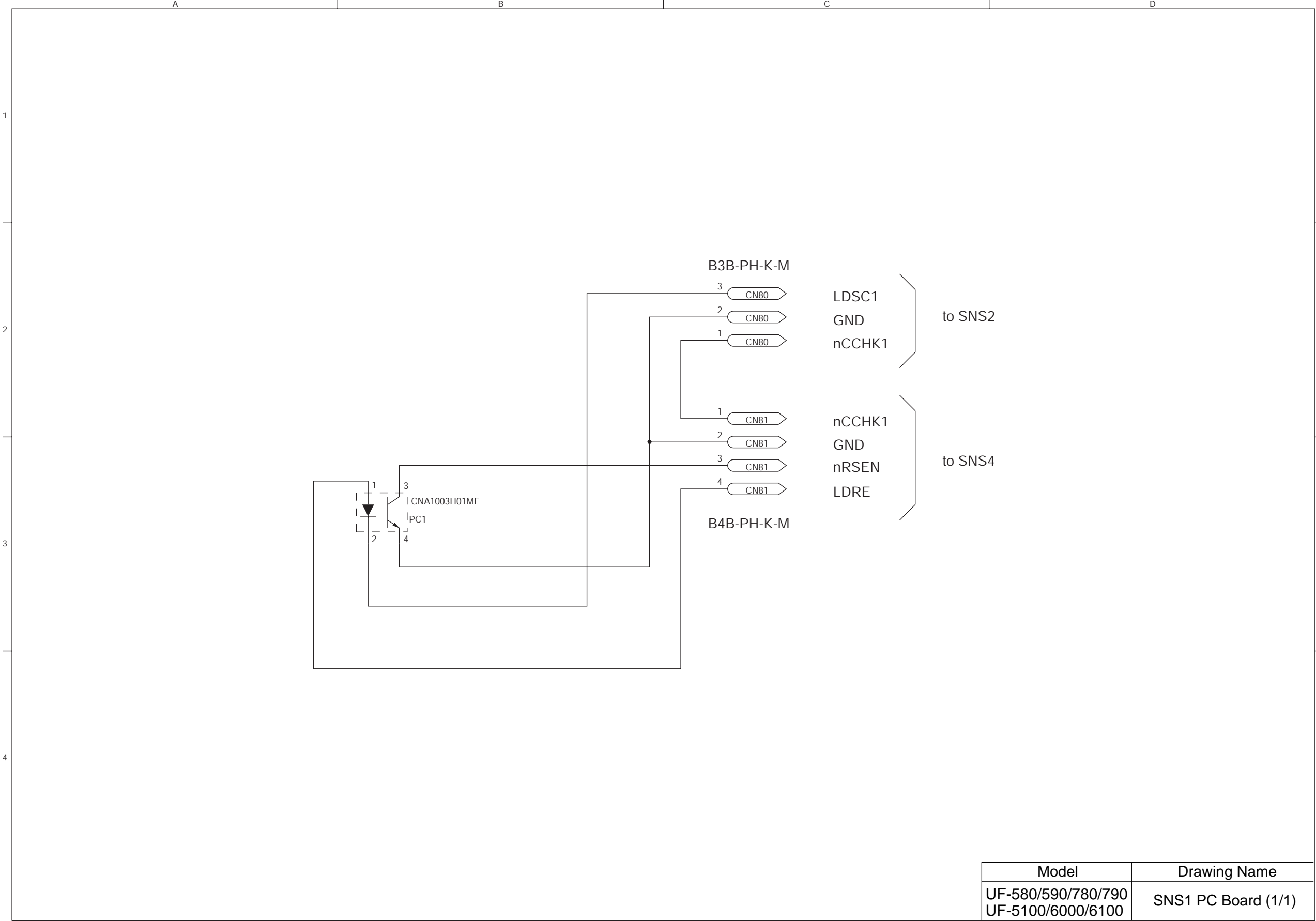



## 10.7. SNS2 PC Board

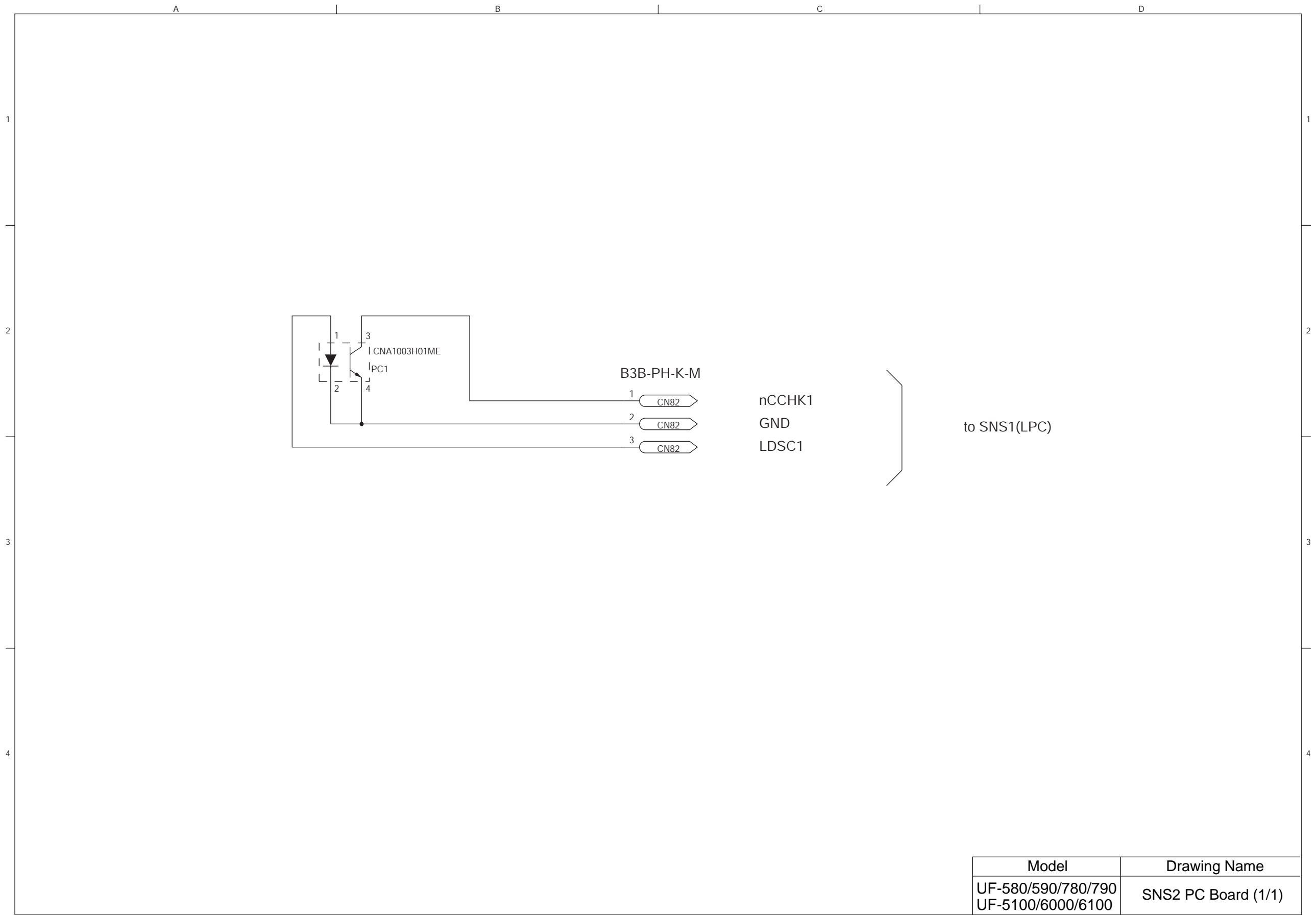

10.8. SNS3 PC Board

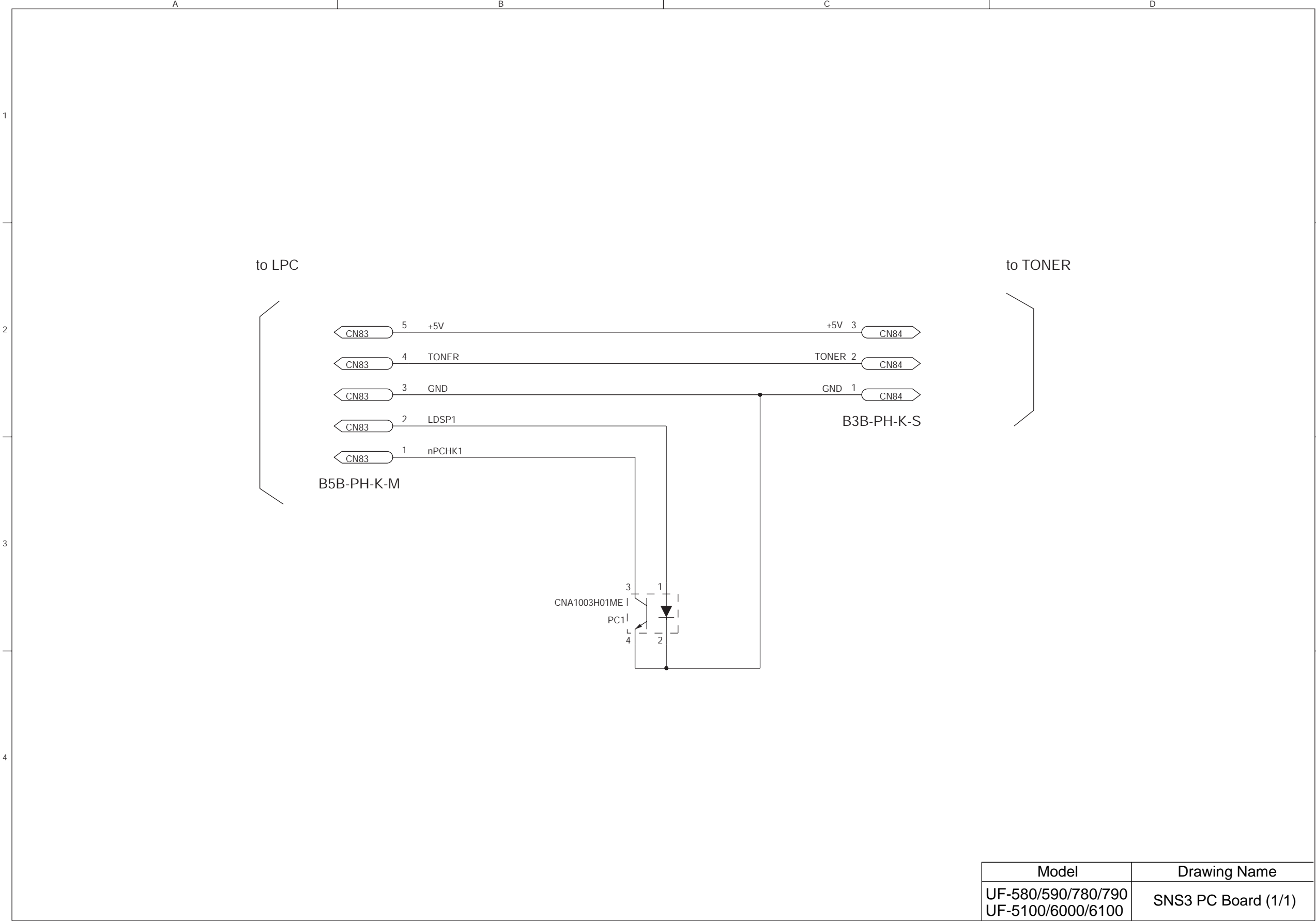

Model	Drawing Name
UF-580/590/780/790 UF-5100/6000/6100	SNS3 PC Board (1/1)

# 10.9. SNS4 PC Board

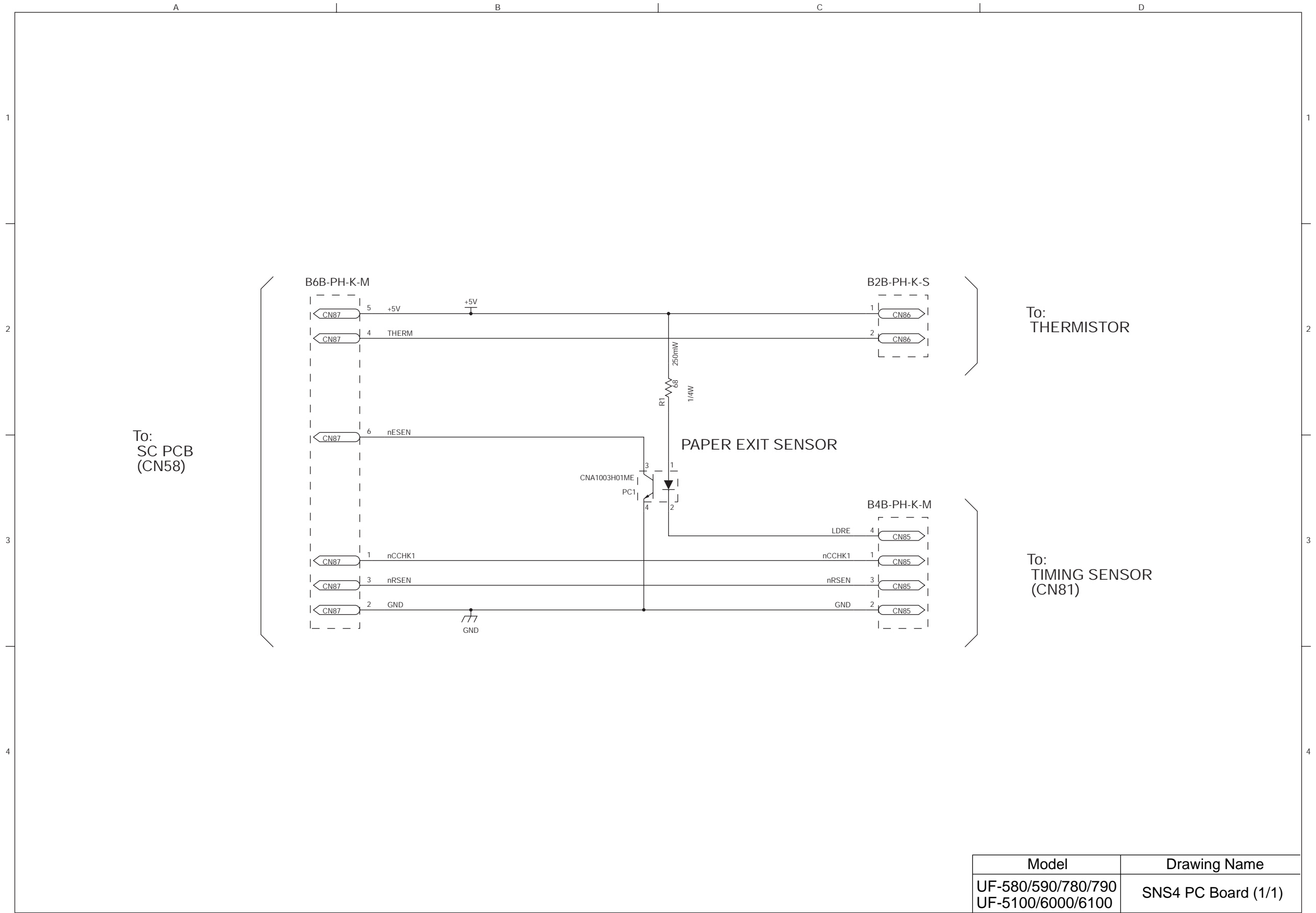

10.10. CCD PC Board (For UF-580/590/780/790)

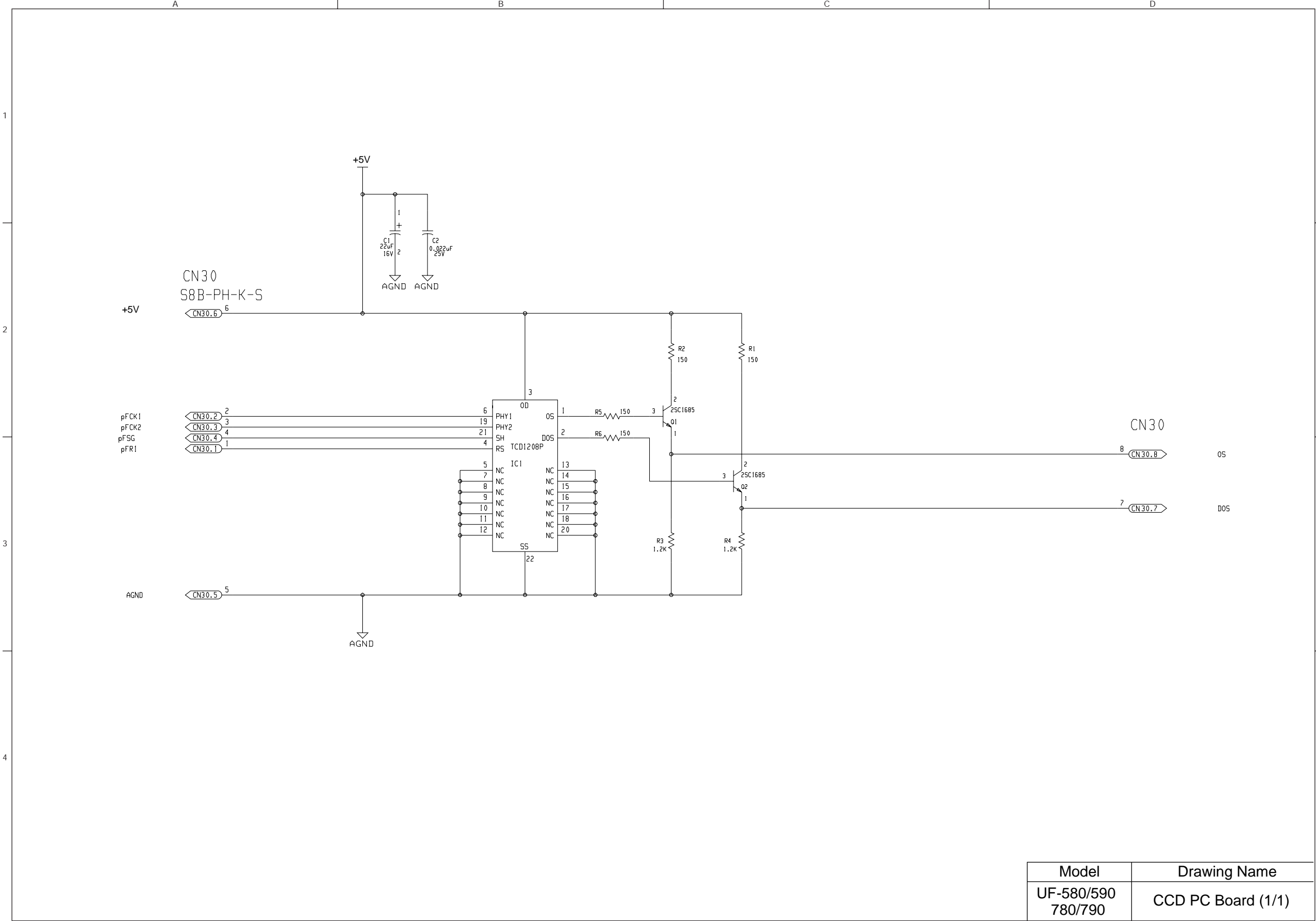

# 10.11. CCD PC Board (For UF-5100/6000/6100)

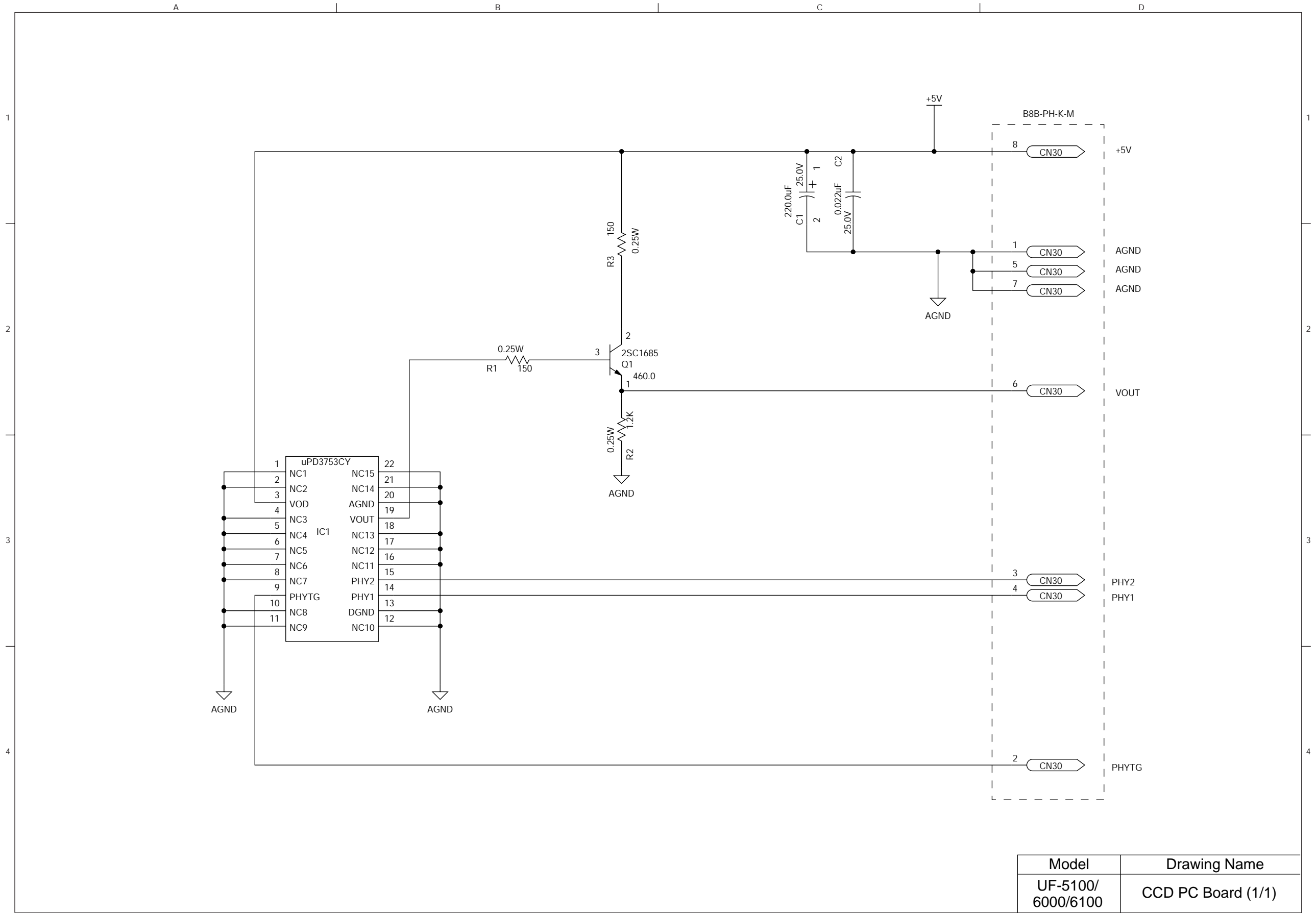

Model	Drawing Name
UF-5100/ 6000/6100	CCD PC Board (1/1)

10.12. ILS PC Board

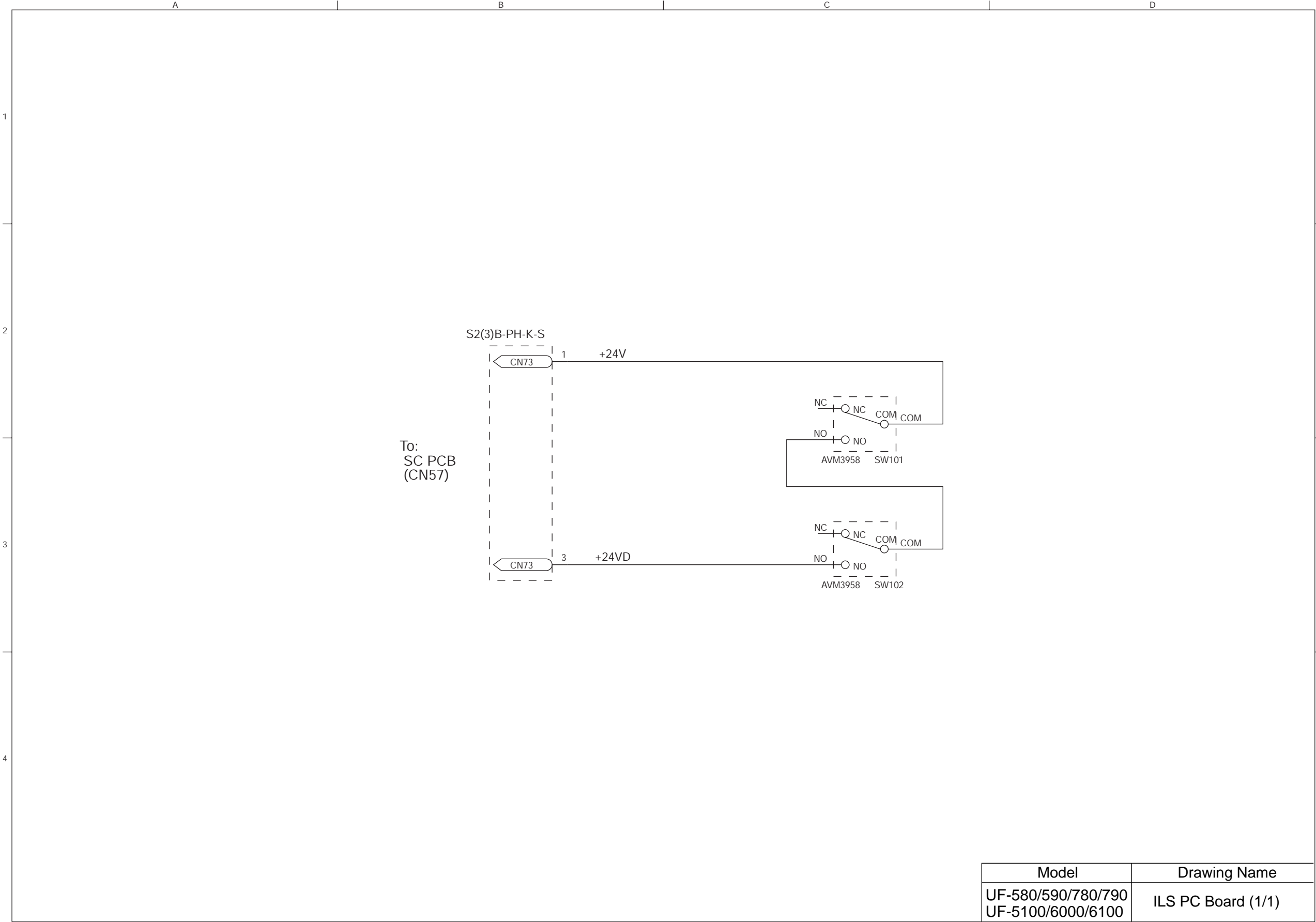

Model	Drawing Name
UF-580/590/780/790	ILS PC Board (1/1)
UF-5100/6000/6100	

# 10.13. ACI PC Board

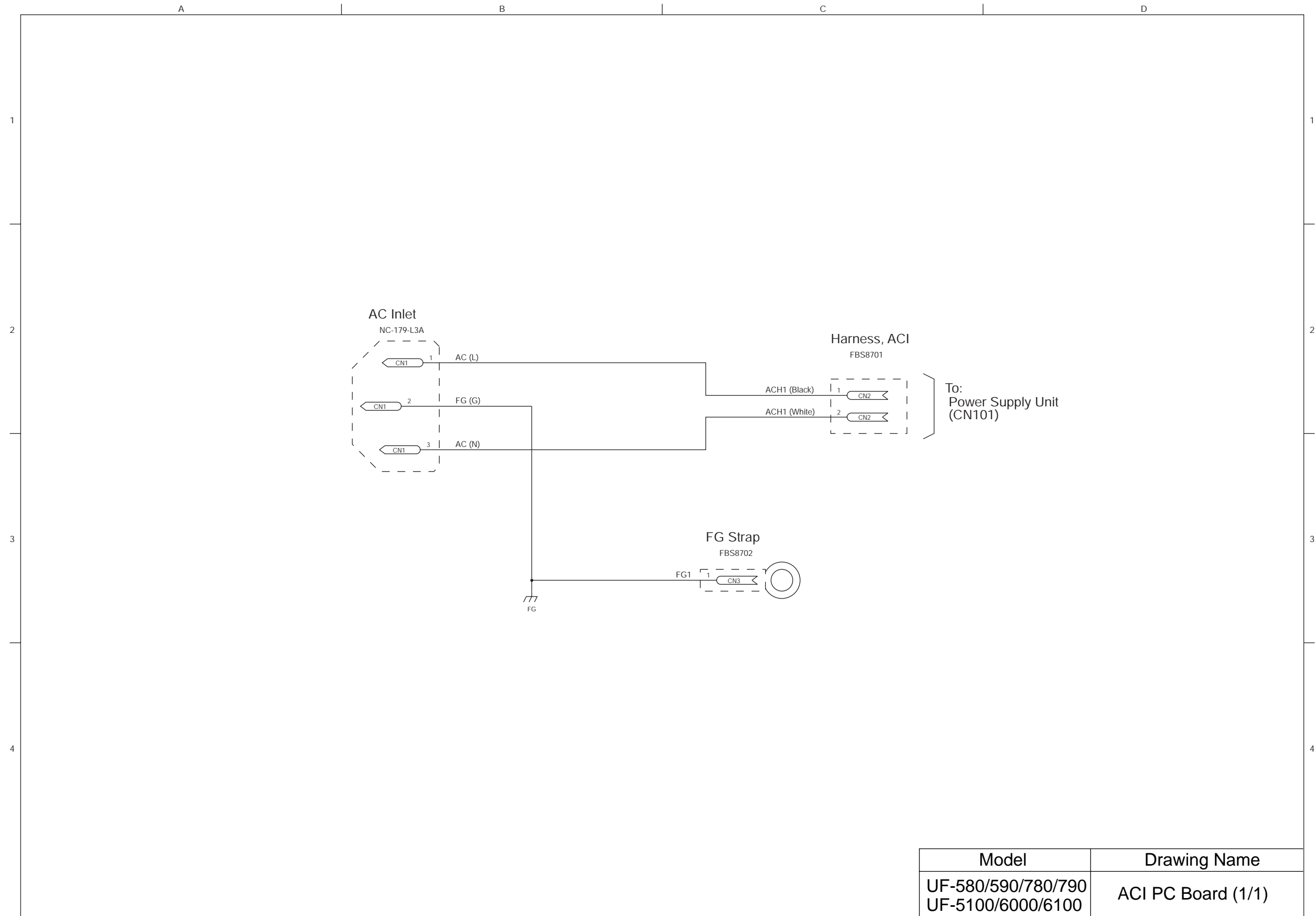

# 10.14. Power Supply Unit (HVPS)

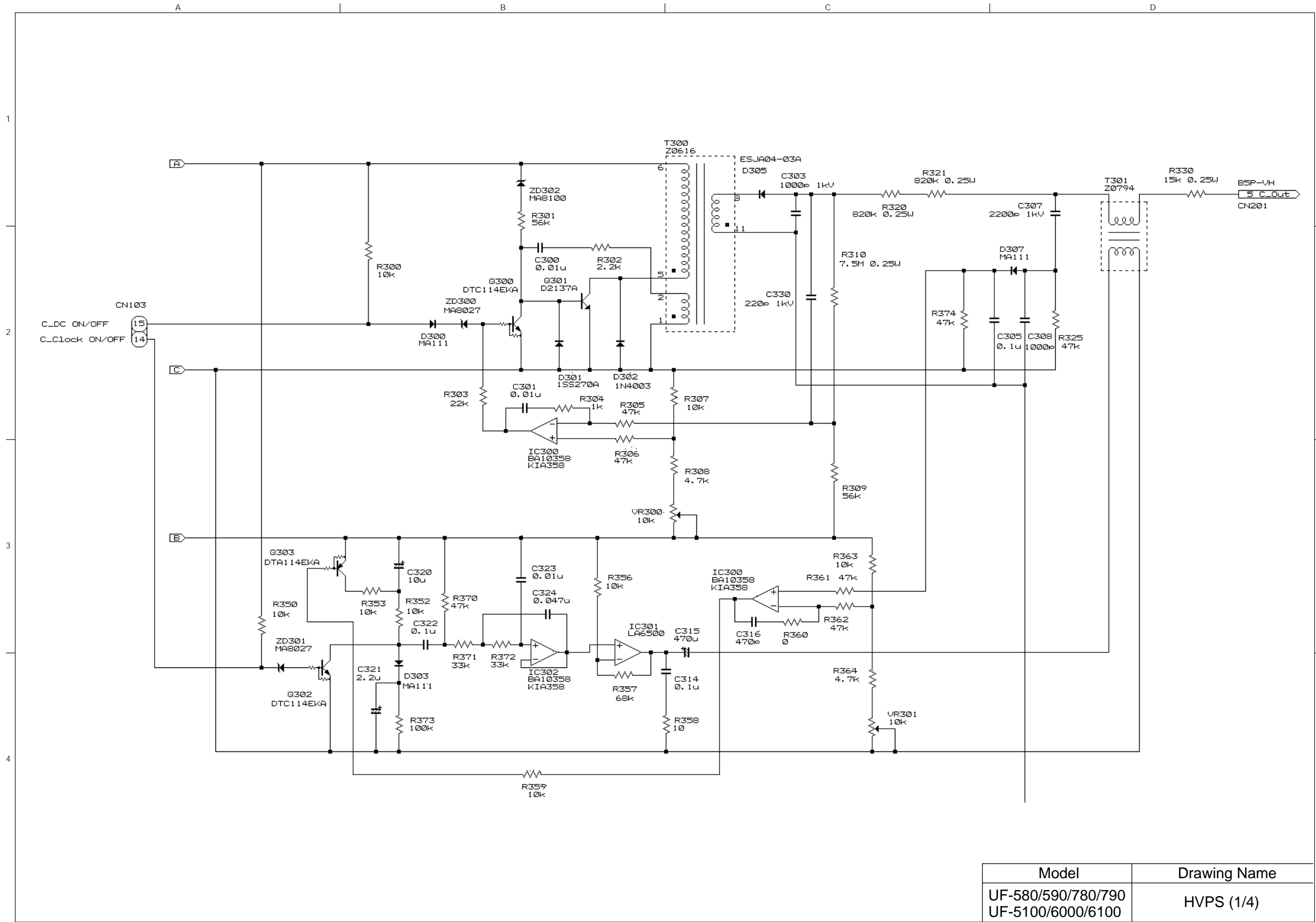

Model	Drawing Name
UF-580/590/780/790	HVPS (1/4)
UF-5100/6000/6100	



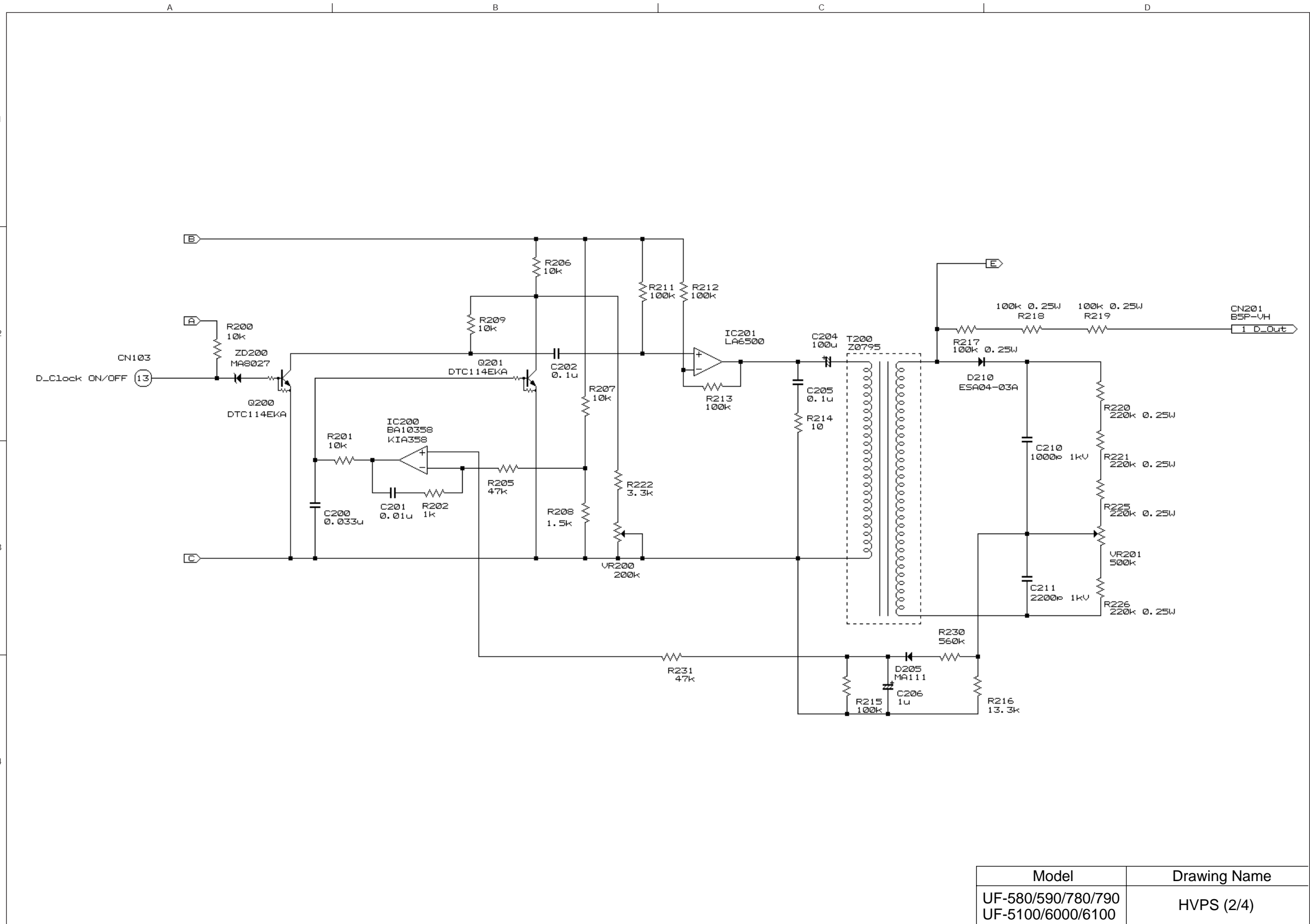

Model	Drawing Name
UF-580/590/780/790	HVPS (2/4)
UF-5100/6000/6100	

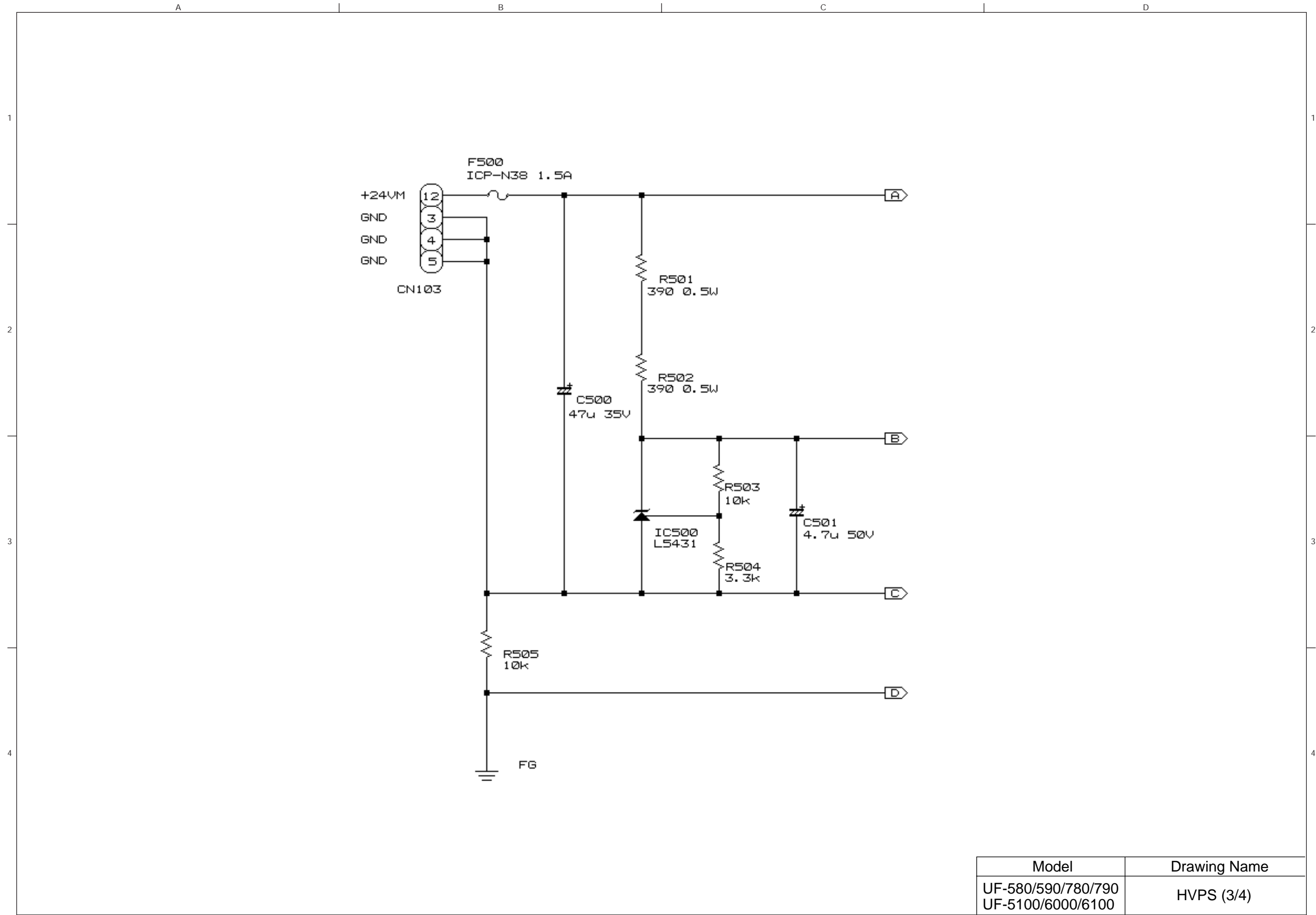

Model	Drawing Name
UF-580/590/780/790 UF-5100/6000/6100	HVPS (3/4)

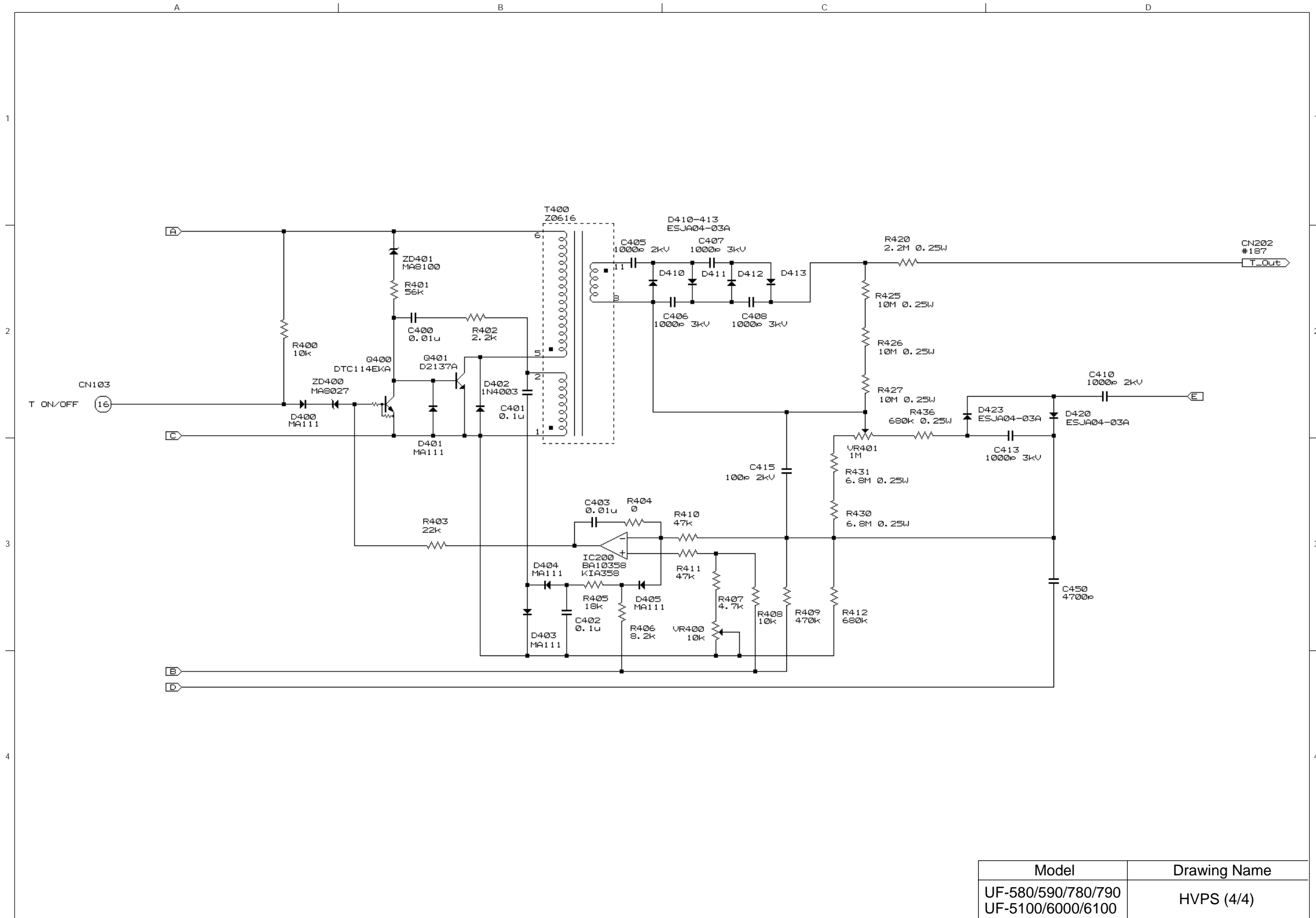

Model	Drawing Name
UF-580/590/780/790	HVPS (4/4)
UF-5100/6000/6100	



